

cantiere del pardo

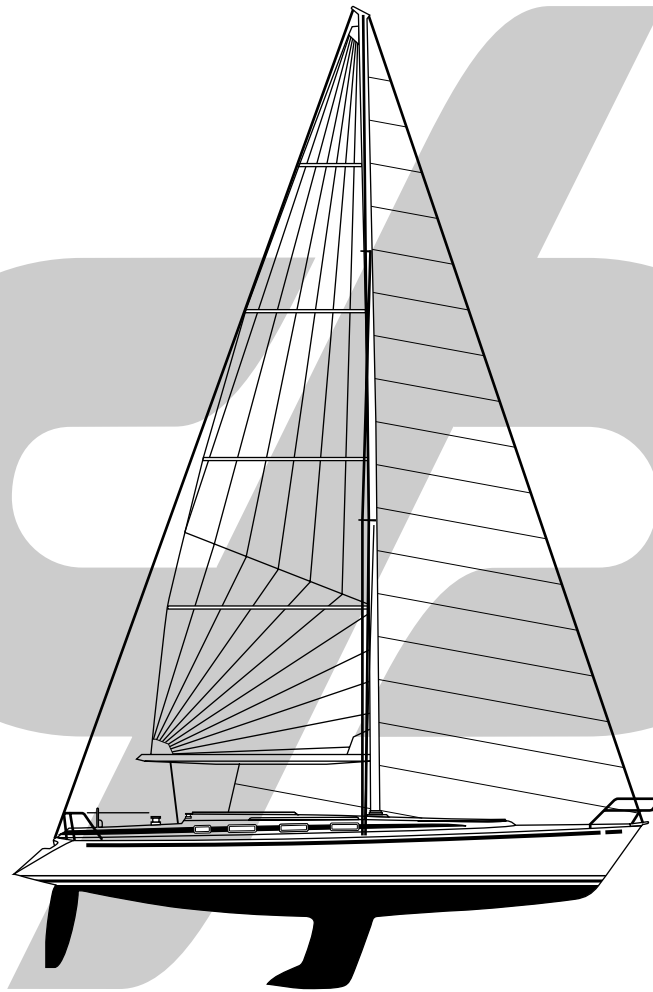

Grand Soleil 43

Owner's Manual



cantiere del pardo

**ALL YOU NEED TO KNOW ABOUT THE
GRAND SOLEIL 43'
Project classification**

A

SEAFARER: vessel designed to cover long range distances, during which the sea state can reach force 8 or more (Beaufort Scale) with waves height exceeding 4 m. Vessel widely self-sufficient.

Hull Identification Number



USE AND MAINTENANCE OF EACH COMPONENT

The copyrights of this owner's manual belong to the Cantiere del Pardo S.r.l. All rights are reserved. According to the laws on copyrights, this manual may not be copied, either partially or wholly without the prior authorization of the Cantiere del Pardo S.r.l. No copies may be made for third parties, regardless of whether these are sold or otherwise, but the entire material purchased may be sold, given as a gift or leased to third parties. According to the provisions of this law, the copy includes the translation in another language or layout.

© Cantiere del Pardo, 1998 – Via Selva, 10 - 47100 Forlì

Tel. 0543/782404 • Telefax 0543/782405

cantiere del pardo

Grand Soleil 43

Owner's Manual

Introduction

The following manual has been conceived to help you using your boat safely and pleasantly. It contains details about construction, systems, equipment on board and many other tips and information about practical use and maintenance.

We invite you to read it carefully to achieve the necessary familiarity before sailing your boat.

If this is your first boat or if you are not familiar with this type of craft, for your safety and pleasure make sure to have gained enough experience before you handle the boat. Your local dealer rather than your yacht club or national association will be glad to show you a nautical school or an expert instructor.

ALWAYS KEEP THIS MANUAL IN A DRY AND SAFE PLACE AND HAND IT OVER TO THE NEW OWNER IN CASE YOU SELL THE BOAT

Summary

+	F O R E W O R D	<p>Introduction vii</p> <p>How to consult this manual, ix- Explanation of Terms, x- Reference Symbols, x.</p> <p>Notes regarding Environmental pollution, waste materials, Main accident-prevention rules and Fire hazard ... xi</p> <p>Environmental pollution and waste materials, xi - Main accidents-prevention rules, xii - Safety at sea xii - Suggestions, xiv - Fire hazard, xv - Fire-fighting equipment: standar location, xvii</p>
+	C H A P T E R	<p>1 Technical data 1.1</p> <p>Specifications, 1 - Certification, 1 - Sail plans, 1</p>
+	C H A P T E R	<p>2 Anchor Windlass 2.1</p> <p><i>Instructions, 1 - Recommendations, 1 - Maintenance, 2</i></p>
+	C H A P T E R	<p>3 Auto pilot (Opt) 3.1</p> <p><i>Recommendations and Precautions, 1 - Maintenance and Instructions, 2</i></p>
+	C H A P T E R	<p>4 Battery Charger (Opt) 4.1</p> <p><i>Instructions, 1 - Caution, 1 - Diagram, 2</i></p>
+	C H A P T E R	<p>5 Bilge Pumps 5.1</p> <p>Manual Bilge Pump, 1 - Electric Bilge Pumps, 1 - <i>Recommendations, 1 - Maintenance, 2</i> - Bilge pumps: Location of the components, 3</p>
+	C H A P T E R	<p>6 Brightworks, Paint-Finish, Maintenance of Surfaces ... 6.1</p> <p>Deck and Top Sides, 1 - <i>Small Repairs to the Deck and Top Sides, 1</i> - Teak Deck (Opt), 2 - Hull below Waterline, 2 - Interiors, 3 - Stainless Steel, 3 - <i>Maintenance, 3</i></p>
+	C H A P T E R	<p>7 Electrical System 7.1</p> <p>12 Vdc network, 1 - <i>Recommendations for 12 Vdc network, 1</i> - 12 Vdc network: the batteries, 2 - 12Vdc sockets, 3 - Fuses, 3 - Magneto thermal switches, 4 - <i>Precautions, 4</i> - Opening the electric panels, 4 - <i>Instructions, 4</i> - 12 Vdc Control Panel, 5 - Switches group: <i>SERVICES, 6 - PUMPS, 6 - RUNNING LIGHTS, 7 - INSTRUMENTS, 7</i> - 220 Vac network, 8 - <i>Cautions, 8</i> - 220 Vac Electrical panel, 9 - 220 Vac sockets, 9 - Water tank gauge, 9 - Fuel tank gauge, 9</p>
+	C H A P T E R	<p>8 Engine: System and Mechanics 8.1</p> <p>Fuel System and Tank, 1 - <i>Recommendations and precautions, 2 - Maintenance, 2</i> - Engine Water Cooling System, 2 - <i>Maintenance, 3</i> - Engine Panel, Control Lever and Engine Cut-Off push button, 3 - <i>Instructions, 4</i> - Engine start-up, 4 - <i>Instructions for engine start-up, 4</i> - Running-in, 5 - Engine shut-down, 5 - General Recommendations and Precautions for Using the Engine, 6 - Gear box, 6 - S Drive rubber gasket, 6 - Exhaust, 7 - Access to engine, 7 - Ventilation of engine compartment, 8 - <i>Precautions, 8</i></p>

+

C H A P T E R	9	Galvanic protection	9.1	
		Propeller Shaft, 1 - Main engine, 1 - Water Heater, 1 - General recommendations, 1		
C H A P T E R	10	Genoa furler	10.1	
		<i>Instructions, 1 - Maintenance, 1</i> - Genoa furling system: diagram, 2		
C H A P T E R	11	Hardware: Deck hardware and fittings	11.1	
		<i>Identification of Deck and Fittings, 1 - Functions of the Deck Fitting, 1 - General Maintenance, 1</i> - Deck Hardware and Fittings: diagram, 2 - Running riggings, 3 - Regular maintenance, 3 - tables, 4		
C H A P T E R	12	Hatches and Portholes	12.1	
		<i>Recommendations and Precautions, 1 - Maintenance, 2</i>		
+	C H A P T E R	13	Haulage	13.1
		Lifting, 1 - Lifting slings position, 2		
C H A P T E R	14	Mast	14.1	
		Stays, 1 - General guidelines for mast tuning, 1 - Tuning, 2 - Recommendations for the tuning of the Babystay and the Inner Forestay, 3 - Backstay, 3 - Shrouds, 3 - Tuning the shrouds, 3 - Recommendations for the tuning of the standing rigging, 4 - Mast recommendations and periodic checks, 5 - Mast maintenance, 5 - Recommendations for the stepping and unstepping of the mast, 6 - Halyard Exits on the Mast: diagram, 7		
C H A P T E R	15	Navigational Instruments	15.1	
		Compass, 1 - Instruments Electrical Supply, 1 - Depth Sounder Transducer (Opt), 1 - Log Transducer (Opt), 1 - Mast Head Units and Aerials, 2		
C H A P T E R	16	Propane gas system	16.1	
		<i>Stove Lighting Instructions, 1 - Cautions, 1 - Maintenance and periodical checks, 2</i> - Propane smell, 2 - Changing a propane tank, 3 - Propane gas system: diagram, 3		
+	C H A P T E R	17	Propeller	17.1
		<i>Recommendations, 1 - Maintenance, 1</i>		
C H A P T E R	18	Reefs	18.1	
		<i>Instructions, 1</i> - Taking in a reef, 2 - Letting out a reef, 2 - Warning notices and advice, 3		
C H A P T E R	19	Refrigeration system	19.1	
		Frigomatic Appliance, 1 - Precautionary notices, 1 - Frigoboat Appliance (Opt), 2 - Other installation components, 2 - Maintenance, 2 - Refrigerator system: diagram, 3		

+

+

C H A P T E R	20	Rudder	20.1	
		Bushings and Bearings, 1 - Steering Gear Elements and Cables, 1 - <i>Precautions</i> , 2 - <i>Maintenance</i> , 2 - Access to Steering Gear Elements, 2 - Instruction for Installing the Emergency tiller, 3		
C H A P T E R	21	Sails	21.1	
		<i>Warning notices</i> , 1 - <i>Maintenance</i> , 1		
C H A P T E R	22	Sea Cocks and Drains - Summary Diagram	22.1	
C H A P T E R	23	Toilets	23.1	
		Instructions for the use of the marine toilets, 1 - <i>Cautions</i> , 1		
C H A P T E R	24	Tools to carry on board	24.1	
C H A P T E R	25	Waste water drainage from shower and sinks	25.1	
+		Shower waste water drainage installation, 1 - <i>Maintenance</i> , 2 - Sinks drainage, 2 - <i>Warning notices</i> , 2		
C H A P T E R	26	Water Heater	26.1	
		<i>Instructions</i> , 1 - <i>Maintenance and Precautions</i> , 2		
C H A P T E R	27	Water System	27.1	
		Tanks, 1 - <i>Tank inspection</i> , 2 - <i>Filling instructions</i> , 2 - Pressure water system, 2 - <i>Instructions</i> , 3 - Foot pump fresh water system (Opt), 3 - Sea water system to galley sink (Opt), 4 - <i>Cautions and general precautions</i> , 4 - <i>Maintenance</i> , 5 - Fresh water system: location of the principal compo- nents, 6 - Water system flow chart, 6 - Fresh water manifolds diagrams, 7 - Bilge selectors diagrams, 7		
C H A P T E R	28	Winches	28.1	
		<i>Cautions</i> , 1 - <i>Maintenance</i> , 1		
+	C H A P T E R	29	Wintering	29.1
		Batteries, 1 - Bilge, 1 - Bilge pumps, 1 - Canvas, 2 - Deck fittings, 2 - Electronic instruments, 2 - Engine, 2 - Fire extinguishers, 3 - Fuel tank, 3 - Hatches, 3 - Hull bottom, 3 - Hull topsides, 4 - Interiors, 4 - Propane gas, 4 - Running rigging, sheets and ropes, 4 - Sails, 5 - Seacocks and hose clamps, 5 - Waterworks, 5 - W.C., 5 - Tips for a safe winter mooring, 6		
C H A P T E R	30	Yacht's trim	30.1	

+

Introduction

The present manual has been conceived by Cantiere del Pardo, to provide the user of the Grand Soleil 43' with useful information on the on board systems of the yacht and to allow our customers to utilize the 43' to its full potential in the greatest safety.

This manual, obviously, can not replace the fundamental knowledge, experience and seamanship required to sail a yacht in the same class as the Grand Soleil 43'. The user of such a yacht should have acquired through direct experience or through the hiring of a professional crew the necessary skill to safely operate the vessel which can not be provided by a manual.

We strongly recommend the user to read carefully the information provided and follow all the recommendations that the Builder has included in this booklet: they will allow him to take full advantage of the yacht's performance in the greatest safety.

The Grand Soleil 43' is the result of a great effort by the Cantiere del Pardo to build an extremely comfortable and safe yacht utilizing the best materials, components and systems available, integrating them to create a very innovative yacht.

In addition to reading all the technical data provided in this owner's manual we recommend a careful reading of all the manufacturers manuals and booklets of the various components installed on the yacht. Reference must be made to these for all maintenance and use of the equipment.

Cantiere del Pardo reserves the right to modify the type and position of any equipment and accessories entirely at its discretion.

Owners must always consult this manual before undertaking any work which is not routine maintenance.

+

The Grand Soleil 43', as delivered, is structurally sound and in proper trim. All modifications must be carefully studied and calculated by professionals in order to maintain the structural integrity and stability of the yacht as designed.

The Cantiere del Pardo congratulates you on your choice! Please do not hesitate to contact us for any explanations you may require.

Il Cantiere del Pardo

+

+

+

+

How to Consult This Manual

This manual contains the information, drawings and detailed diagrams on the use and maintenance of the yacht, its equipment and accessories.

The chapters have been listed in alphabetical order for easy reference. Es:

Mast

The subjects in each chapter are presented as follows:

+

Shrouds

and analysed in the following order:

- description
- instructions on use
- recommendations and precautions
- maintenance

+

Wherever necessary, reference is made in the text to specific diagrams and/or drawings.

+

Explanations of Terms

Port-Starboard The terms “Starboard” or “Port Side” always refer to the direction from stern to bow. When specific reference is made to another direction, the term "starboard" is replaced by “right” and "port" by "left".

Open-Closed When the terms “open” or “closed” refer to an exhaust valve, seacock or valve, they indicate the position of the control lever or handle:

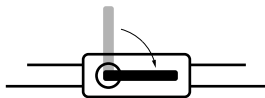

- when the lever is **parallel** to the pipes and the valve itself, the valve is **open**;

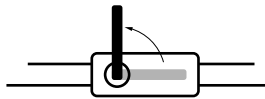

- When the lever is at **right angle** to the pipes and the valve itself, the valve is **closed**.

Opt. • indicates optional equipment or system.

Reference Symbols



Danger This symbol calls attention to an intrinsic danger which could retail major risk of death or serious injury if the appropriate safety measures are not followed.



Warning This symbol calls attention to a risk of injury or even death if certain safety precautions will not be followed.



Attention This symbol calls attention to recommended safety measures in case of dangerous practices and uses that may cause damage to the boat or personal injury.



Attention This symbol calls attention to **possible environmental pollution**.



Maintenance calls attention to the maintenance procedure and needs concerning the matter.



Use This symbol calls attention to the specific use and needs of the subject.



Calls attention to the various parts of the description of an item.

Notes regarding Environmental pollution, waste materials, Main accident-prevention rules and Fire hazards

The following brief summary of the current EEC. rules about environmental pollution, waste materials and accident-prevention rules is valid only if the boat is used exclusively for private use and without crew officially hired on board.

These rules derive from the International **Convention for the Safety of Human life at sea** issued in London on February 1st 1974 and following revisions and modifications.

Environmental pollution and waste materials

The environmental pollution is divided in three categories:

- ◇ Waters
- ◇ Air
- ◇ Ground
- Oil free and black waters (*that means those containing only human organic wastes*) may be discharged in open sea. Within coastal waters they should be kept in specific tanks and than discharged at open sea or through adequate systems available on the quay or by mean of sewage draining trucks.
- The regulations concerning the air pollution that a boat can produce are basically limited to the prohibition of using sprays containing C.F.C. gas and to the limitation of external noises that, at a distance of 5 mt. from the boundary of the vessel, should not exceed 65 dB(a) (decibel) from 6 a.m. to 10 p.m. and 55 dB(a) from 10 p.m. to 6 a.m.
- The ground pollution concerns the solid wastes unloaded on land.



In other words the EEC normative law #. 91/689 concerning the recreational boats provides as follows:

- It is for bidden to discharge at sea any “not-biodegradable product” either foodstuff or commercial products.
- Within coastal waters the **normal wastes** are considered as **urban wastes** and therefore can be closed into hermetic plastic bags and than placed into trash bins.

- The **special wastes** must be placed in special containers or, if not available, handed to the local collectors in accordance with the port authority regulations. Considered as such are the following products:
 - oily waters or mixtures (such as bilge water);
 - black and/or white waters from W.C. or sinks;
 - oils (fuels, additives and lubricants);
 - chemical products labelled as “toxic” (battery acids, paints, thinner etc. including their containers);
 - spray products containing C.F.C. gas;
 - batteries;
 - expired distress flares;
 - expired pharmaceutical products;
 - products containing lead or asbestos;
 - etc.



Remember that, according to the EEC laws, until the above products will not be handled to the proper collectors, you will be considered as holder and as such you can be persecuted in case of abusive discharge. If within the harbour area the specific trash bins are not available, the competent authority is always the Harbour Master.



Main accident-prevention rules

Operation of any vessel is under direct responsibility of the captain!



Safety at sea

It falls upon the yacht Operator to check before departure that all safety equipments required by law are present on board and in good working order! For updated requirements, contact your Local and National boating authorities. The yacht and it's equipment should be kept in optimum condition: hull, machinery and safety features should be inspected and overhauled at the proper expiry intervals (refer to each system owner's manual).

- Before sailing the vessel, the captain and crew must be thoroughly familiar with all on board systems and standard safety measures.



In addition to Standard, Local, National and International boating laws, uses and practices, the following precautions must be followed while under way:

- All passengers must be made aware of the location and use of safety equipment (i.e. life raft, life jackets, fire extinguishers, fuel remote cut off).
- All passengers must be aware of fire hazards.
- The vessel must be properly ventilated while engines or generators are in operation.



Danger !!

Carbon Monoxide Hazard

The combustion of fossil fuels produces great quantities of Carbon Monoxide. This is a dangerous odourless and colourless gas. Proper ventilation of the vessel is necessary while operating engines or generators especially at low speeds, while drifting or at the dock.

- Follow proper fuel loading procedures.
- Follow the “Rules of the Road”, keep a sharp lookout and follow all safe speed regulations.
- Do not overload the vessel, particularly either fore or aft and distribute equally the weights to keep a proper trim.
- Require that all passengers are seated and in the cockpit while the vessel is in operation.
- Always wear appropriate footwear.



Warning

Operating a vessel while under the influence of any drug, including prescription and non prescription drugs, alcohol, illegal drugs is a felony!!

Although the majority of the following recommendation has been widely mentioned in the individual items of this booklet, it will be useful to remind some general rules.

- First of all it is most important to check that all the compulsory safety equipments have a visible label proving that the item is an approved type and still valid. These equipments include:
 - all the emergency floating devices (*life jackets, life rings with floating lights, life rafts, etc.*);
 - distress signals (*flares, EPIRB and/or Locat, VHF, SSB etc.*);
 - fire extinguishers (*both fixed and/or movable in adequate number, clearly indicated and of easy access*).
 - approved first aid kit and chemistry products still valid.

Suggestions

- Make sure that all the safety equipments (*life rafts, life jackets, etc.*) are always clear and ready for use.
- Do not leave hatches and lockers wide open as they can be dangerous pitfalls.
- Check carefully that all the handles, railings, deck walkways, hatch tops and steps are strong, in good conditions and free from any greasy substance that could make them slippery.
- Check periodically the good conditions of the steering gears, the emergency tiller, the standing as well as the running rigging, blocks, winches, etc.
- The Cantiere del Pardo delivers his boats well finished and thus generally free from dangers of accidental injuries. Should you add extra fittings, make sure not to leave exposed any sharp or harmful object such as screws, bolts or any sharp edge in general.
- We want to remind you that the above mentioned International Convention of London for the human survival at sea provides that at least once a year, but for sure before any transcontinental passage all the passengers and the crew should carry out a rescue simulation introduced by seven or more short whistles or siren sounds followed by a long one; all this should be duly described and recorded in the log book.
- Finally we recommend to use yachting shoes and gloves while manoeuvring.



Fire hazard

On any vessel, fire represents a very serious hazard. All measures should be taken to avoid and prevent all fires.

Before operating this vessel, the captain must be aware of the following fire preventing regulations:

This craft when in service shall be equipped with all the fire fighting gears and complements provided for by law, positioned as per builder indication clearly marked with adhesive tags (ref. to diagram on page xvii).

It is the responsibility of the craft owner/operator to:

- Please note that CO₂ may damage the engines interior should it be aspirated in the engine cylinders.
- have fire fighting equipment checked at intervals indicated on the extinguisher;
- replace fire fighting equipment, if expired or discharged, by devices of identical or greater fire fighting capacity;
- inform members of the crew about the location and operation of fire fighting equipment and the location of escape hatches;
- ensure that fire fighting equipment is readily accessible also when the cabins are occupied by passengers.



Danger!

- **Never:**
 - obstruct passage ways to exits and hatches;
 - obstruct safety controls, e.g. fuel valves, gas valves, switches of the electrical system;
 - obstruct portable fire extinguishers stowed in lockers;
 - leave the craft unattended when cooking and/or heating appliances are in use;
 - use gas lights inside the craft;
 - modify any of the craft's systems (*especially electrical, fuel and gas*);
 - smoke while handling fuel or gas;
 - fill any fuel tank or replace gas bottles when machinery is running or when cooking or heating appliances are in use.
- Keep the bilges clean and check for fuel and gasleaks at regular intervals.
- Do not fit free hanging curtains or other fabrics in the vicinity of or above cookers or other open flame devices.

+

- Combustible material shall not be stowed in the engine space. If non-combustible materials are stowed in the engine space they shall be secured from falling against the machinery and/or obstruct the access to it.



Danger

The hand extinguishers use CO₂ as an extinguishing medium. It shall be used only to fight electric fires.

To avoid asphyxiation after discharge:

- LEAVE THE AREA IMMEDIATELY and VENTILATE BEFORE REENTERING.
- Escape facilities other than the main companionway shall be identified by the appropriate ISO symbol.

+

The Cantieri del Pardo also recommend:

- 1 Avoid fuel spillage in the bilge, especially in the engine room. Should a fuel leak develop:
 - stop immediately the engine;
 - assess leak location and if possible repair, after closing fuel valve;
 - soak up the spilled fuel before restarting the engine.
- 2 Take particular care to avoid direct contact with high heat sources: cooking ranges, halogen light bulbs, boiler etc.
- 3 As a pleasure craft operator, you should be familiar with standard fire fighting techniques and procedures and the use of fire extinguishers.

+

Should a fire develop follow standard fire safety procedures.

- 1 Don't panic and keep the passengers calm.
- 2 Stop vessel.
- 3 Assess fire location and source.
- 4 Avoid inhaling smoke.
- 5 Extinguish fire following standard fire extinguishing techniques.

+

+ Fire-fighting equipment: standard location

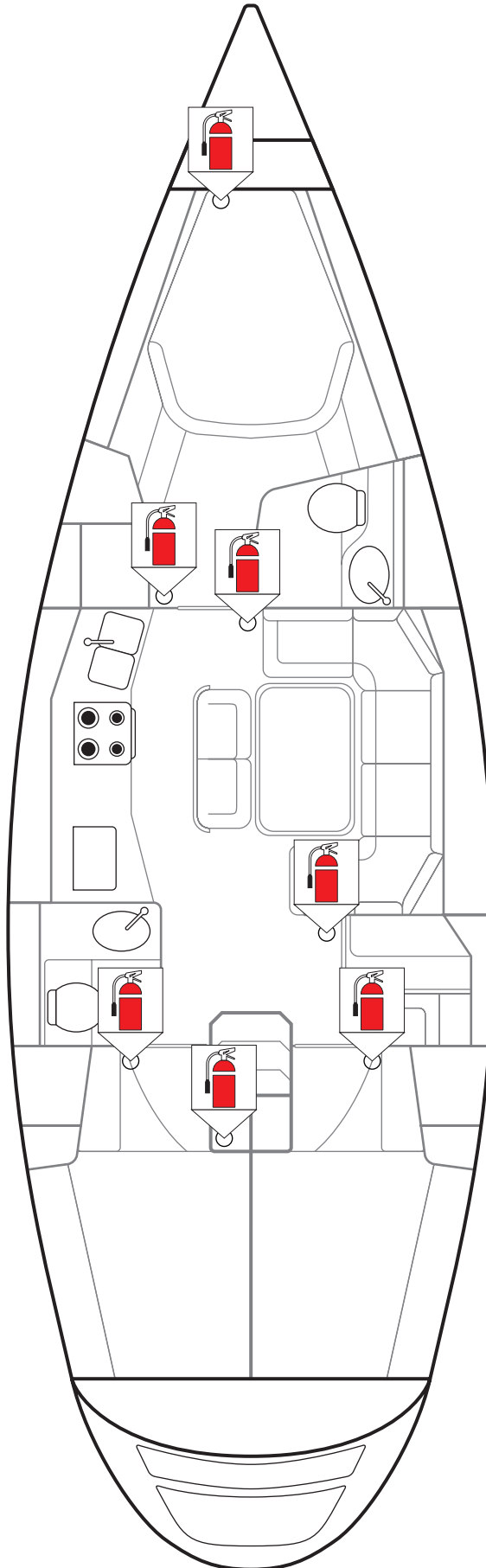

Technical Data

Specifications

Overall Length	mt	13,20
Hull Length	mt	12,90
Waterline Length	mt	10,90
Maximum Beam	mt	3,99
Overall clearance (standard)	mt	4,04
Overall clearance (racing)	mt	4,18
Draft (standard)	mt	2,10
Draft (reduced)	mt	1,70
Displacement	Kg	8.500,00
Ballast	Kg	3.100,00
Sail Area (standard mast)	m ²	95,05
Sail Area (extended mast)	m ²	98,86
Sail Area (racing mast)	m ²	114,41
# of berths	n.	6/8
# max. of passengers	n.	10
Fuel Capacity	Lt.	160,00
Water Capacity	Lt.	400,00
Engine (Yanmar 4JH2E)	HP	40,00
Design	J & J Design	

Certification

Issued by **R.I.Na Via Corsica, 12 - 16128 Genova (I)**
 Certificate #

Sail plans

	Standard		Extended		Racing	
	m ²	sq.ft.	m ²	sq.ft.	m ²	sq.ft.
Main sail	37,17	400,09	38,77	417,32	49,55	533,36
Furling Genoa	46,81	503,86	48,74	524,64	52,90	569,42
Light Genoa (Opt)	57,88	623,02	60,09	646,81	64,86	698,15
Olympic Jib (Opt)	37,00	398,27	38,50	414,41	41,75	449,40

Anchor Windlass

The following instructions do not replace the information provided in the enclosed Owner's Manual supplied by the Manufacturer.

- ◇ The Grand Soleil 43' is equipped with an electric (12 Volt DC) anchor windlass type Lofran 1000 Watt for a chain of 8mm .
- ◇ The Anchor Windlass is located in the bow compartment. Its motor is installed in a separate waterproof compartment accessible through the front cabin.
- ◇ The operation of the windlass is accomplished through a control box connected with a wire to the water proof outlet located in the anchor locker.
- ◇ An additional control switch (Opt) is located in the cockpit above the engine panel.

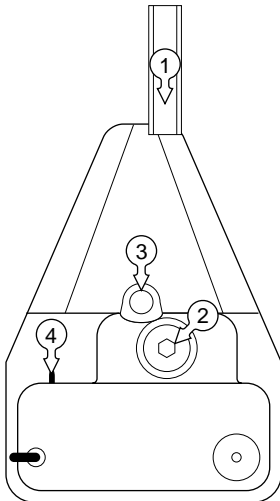

- 1 Chain head
- 2 Chain wildcat
- 3 Chain locker
- 4 Windlass push button control socket



Instructions

- Make sure that the chain is fitted into its "wildcat" guide located under the anchor windlass winch.
- Activate the double breaker located on the 12 Volt DC Service Electrical Panel
- Use the control box in the anchor compartment or the switch in the cockpit (Opt) to hoist or drop the anchor.
- When this operations has been completed, turn off the anchor windlass switch on the Electrical Panel, especially if you leave the boat unattended.



Recommendations

- When replacing the anchor chain make sure that the chain and the wildcat on the windlass are perfectly matched (i.e. if you change from metric to standard size): even small differences will make the chain "jump" and prevent it for working properly.
- Whenever the yacht swings around its anchor, the chain will twist. These twists in the chain might cause the chain to "jump" on the wildcat. To prevent this, unwind the chain when the boat is docked and the anchor just breaks the water surface.
- In the case of system failure, check that the double magneto-thermal safety switch in the 12Vdc Electrical Panel has not tripped automatically. If the magneto-thermal safety switch continues tripping, locate the fault before switching it on again.

« Recommendations



- Always use the anchor windlass with the engine running at 1/2 revs. to prevent excessive drainage of the batteries caused by the high electric consumption of the windlass under heavy load.
 - In case of emergency, the windlass may also be used with the main engine off.



- While operating the anchor windlass, **do not stand too close or in front** of the wildcat to prevent injury if the chain accidentally jumps off the drum.
- The anchor windlass should not be used as a mooring cleat. Never leave the chain in tension but secure it to the mooring cleats as follows:
 - When mooring is completed, attach a strop fastened to the mooring cleats with one, or better, two pieces of cable to one of the chain rings.

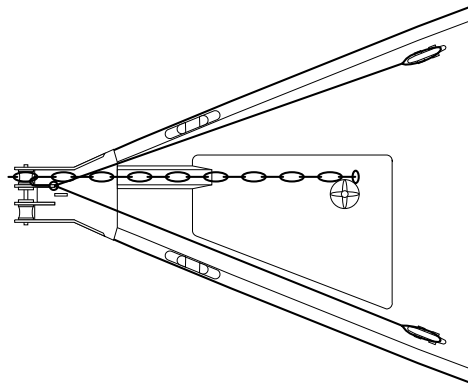

- Release the tension on the anchor windlass slightly, letting chain out so that the load is on the strops and not on the windlass.
- To secure the anchor textile line, tie it to one of the cleats.



Maintenance

As a general rule, the anchor windlass, although placed in the most exposed area of the yacht, does not need any special care.

- Please remember that your windlass is built with component of different metals and, subsequently, is subject to galvanic corrosion in the presence of salt and moisture. By hosing off the windlass with fresh water on a regular basis to prevent salt build up, this problem will be partially avoided.



Always refer to the enclosed Owner's Manual supplied by the Manufacturer.

Auto pilot (Opt)

The following instructions do not replace the information provided in the enclosed Owner's Manual supplied by the Manufacturer.

- ◇ The Automatic Pilot is an Optional equipment that allows to steer the yacht automatically on a chosen course.
- ◇ The Grand Soleil 43' is designed for the installation of an electric automatic pilot, fitted with the control arm directly connected to the rudder stock through the main quadrant.
- The switch for activating the power supply to Automatic Pilot is in the Instrument Section of the 12Vcc Electrical Panel.
- The controls for the Automatic Pilot are located on the control panel of the auto pilot, in the cockpit, in front of the wheel.



Recommendations and Precautions

- Please keep in mind that when the Automatic Pilot is operating, it also moves the steering wheel.
- Make sure that your hands, arms, feet do not get caught between the spokes of the wheel and the bottom of the cockpit or the binnacle.
- Do not leave objects which can prevent the movement of the wheel, such as lines, sheets, bottles etc. in the steering cockpit area.
- Never force the wheel when the Automatic Pilot is operating.
- In case of a major auto pilot malfunction, the linkage between the auto pilot and the steering quadrant on the rudder shaft may be interrupted by pulling the connecting pin. You might want to perform this operation also while racing to reduce the wheel's drag and increase the feel.
- At the same time we would like to remind you that in case of a breakage of the main steering components, you can still be able to maintain the control of the vessel through the auto pilot since it act directly on the rudder stock quadrant bypassing the main steering mechanism.

+



- The Automatic Pilot can assist the crew but does not replace it; remember that at least one crew member must be on deck alert and ready to take over if necessary, above all to avoid the risk of collision with other crafts.



Maintenance and Instructions

Refer to the Manufacturer's Manual



Always refer to the enclosed Owner's Manual supplied by the Manufacturer.

+

+

+

Battery Charger (Opt.)

The following recommendations do not replace the information provided in the Battery Charger Owner's Manual.



- ◇ The battery charger operates under high voltage.
- ◇ It is installed under the seat of the chart table.
- ◇ It is ventilated by an internal fan which exchanges air through the grid located in the front part of the seat.
- ◇ It is equipped with an automatic charge regulator.



Instructions

- Make sure that all breakers in the 220 Volt section of the electrical panel are on the **OFF** position (§ page 7.9).
- Always plug the electrical shore power cord first to the on board inlet, placed on the stern, and only then to the shore power supply on the dock. **Never perform these operations barefoot or near water puddles.**
- Activate the blue breaker (Differential safety breaker) on the 220 Volt AC electrical panel (§ page 7.9).
- Check the input 220 Volt AC Voltmeter (§ page 7.9).
- Activate the **BATTERY CHARGER** breaker on the 220 Vac electrical panel (§ page 7.9).
- Check the output 12 Volt DC Voltmeter (§ page 7.5).



Caution



- Spikes or drops in the 220 Volt (nominal) power lines are frequent especially in crowded marinas. Check for these variations by keeping an eye on the 220 Voltmeter (§ page 7.9).
- The system is designed to withstand voltage variations up to +/- 5% and will function properly only between these parameters. If the variations should exceed these values, disconnect immediately the whole electrical 220 Volt AC system by switching off the blue 220 Vac breaker.



Caution: The battery charger can be cause of electrical shock and fire if damaged or not properly taken care of.

Therefore it is recommended to:

- Never leave the yacht unattended with the Charger ON.

« Caution...



- Never open the protection panel on the outside of the Charger unless the blue 220 AC breaker is off or, even better, pull off the shore plug.
- Never place objects close to the battery charger or its external grid in a way that will reduce it's ventilation.



Always consult the Battery Charger Owner's Manual for instructions and maintenance.

Diagram

- 1 Battery Charger
- 2 Internal fan
- 3 220 Volt AC inlet

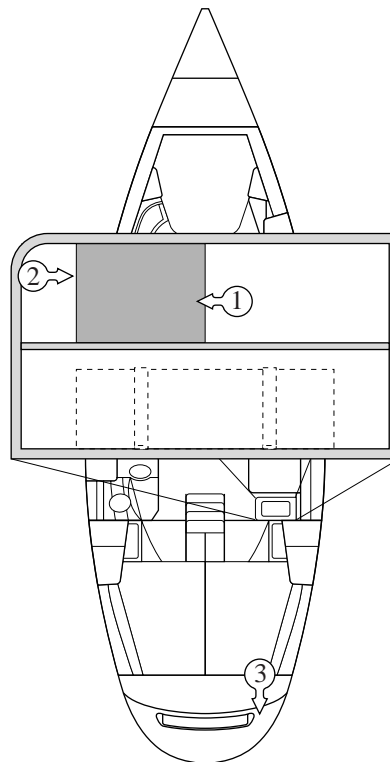

Bilge Pumps

The Grand Soleil 43' is equipped with two separate bilge pump systems:

- ◇ Manual
- ◇ Electric

Refer to the Diagram on page 5.3 for the positioning of the components.



Manual Bilge Pump

- The manual bilge pump is operated by a lever located in the cockpit on the port side of the aft seat. The pump draws water from the main bilge through a siphoning hosepipe protected by a filter and discharges water on the port topside, near the stern.



Electric Bilge Pumps

The two electric bilge pumps are located under the central seat in the saloon and in the engine compartment (§ page 5.3 & 27.6).

- Through the selector **C** (§ page 27.7) located nearby the first pump empties:
 - the mast step bilge (c3)
 - the fore head shower bilge (c4)
- Through selector **D** (§ page 27.7) located in the engine compartment the other pump empties:
 - the aft head shower bilge (D2)
 - the main bilge under the saloon floor (D3)
- Both pumps are powered by the switch **BILGE PUMPS** on the **PUMPS** section of the 12 VDC (§ page 7.6) panel but they are actually activated by the switches located near the sinks of the heads: fwd head group **C** and aft head group **D**.
- A filter is located on each pump suction end of the hoses to prevent the clogging of the pumps.
- Bilge water is expelled through the manifold located in the aft of the port topside (§ page 22.1).

+



Recommendations

- Check periodically that the filters at the ends of the suction hoses of the bilge pumps are not plugged.
- Remember to keep all the bilges clean with specific detergents to prevent clogging of the hoses and the formation of unpleasant odors.
- **Do not pollute!** Heavy sanctions are applied for unlawful discharge of polluting agents, for example oil and soap sludge, in the sea.



Maintenance

- The bilge pumps must be checked regularly and at least once a month:
 - check and clean the filters on the electric bilge pumps suction side.
 - check the condition of the pump and filters gaskets: in the case of leaks, replace the gasket.

+

+

+

Bilge pumps: location of the components

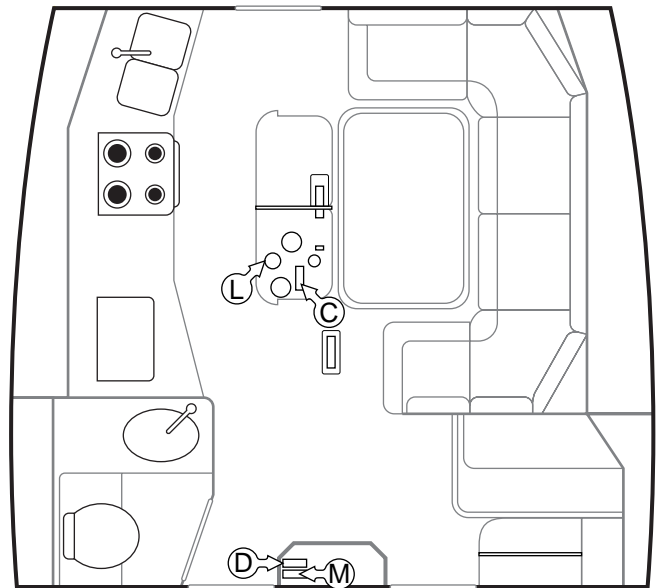
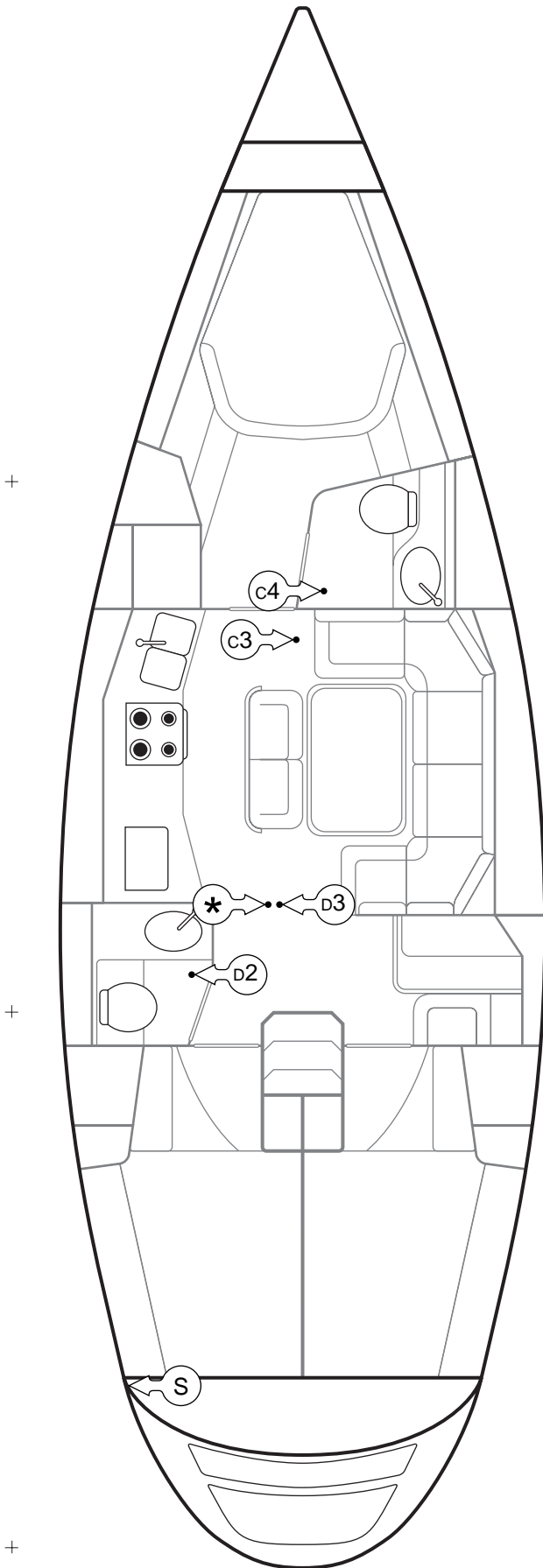

- L Forxard bilges' pump
- C Forward bilges' selector
- c3 Mast step bilge suction
- c4 Fwd shower bilge suction
- M Aft bilges' pump
- D Aft bilges' selector
- D2 Aft shower bilge suction
- D3 Main bilge suction
- * Hand pump suction
- S Over board discharge manifold

Brightworks, Paint-Finish, Maintenance of Surfaces

The surfaces described in this chapter are divided as follows:

- ◇ **Superstructure and top sides**
- ◇ **Teak deck (opt)**
- ◇ **Hull below waterline**
- ◇ **Interiors**
- ◇ **Stainless steel components**

Cantiere del Pardo uses some of the best products and treatments available on the market on the internal and external surfaces of their yachts.



To ensure the best performances, follow these recommendations.

Deck and Top Sides

- ◇ Gel coat requires a certain amount of care and maintenance in order to be kept perfectly clean and glossy.
 - Use a solution of water and neutral soap for normal cleaning.
 - Use specific detergents or kerosene to remove oil and tar stains.
 - Avoid use of acetone, abrasive detergents or chemicals.
 - In the case of stubborn stains, use 600 grit wet-and-dry sandpaper. Use very gently ensuring that you do not remove too much of the gel coat surface. After sanding, polish to restore the original glossy finish.
 - Especially on blue gel coat, use only special boat wax (there are many makes available on the market) at least once a year. The wax protects the gel coat from scratches and dirt and helps preventing loss of pigment.



Small Repairs to the Deck and Top Sides

- Request information from the Cantiere del Pardo about gel coat, “curing time”, percentages and catalysing temperature, but remember that you should not work at a temperatures below 16°C and with high humidity.
- Before starting, thoroughly dry the damaged area and remove all traces of dirt and oil with acetone.
- Sand the area, then remove the dust.

- Mix the correct amount of catalyst to the gel coat; apply the gel coat mixture on the area covering a slightly wider area, since gel coat tends to shrink a little when curing.
- In order to obtain a smooth surface, cover the gel coat with a plastic film and press down.
- When the catalysing process is completed (follow the manufacturer's recommendations for the working times) and the gel coat has hardened, wet sand with wet - and - dry 600 grit paper until smooth.
- Polish and wax to complete the repair.

Teak Deck (Opt)

- Rinse and clean the teak deck regularly with fresh water and a brush with medium hard bristles (too hard ones may scratch the surface) and treat periodically with teak oil (at least once a year).



Caution: it's important to brush always following the wood fibres' direction.

Hull below Waterline

- ◇ The Cantiere del Pardo generally applies anti fouling bottom paint (Opt).
- If the anti fouling paint peels off this could be due to silicon wax residues on the hull when it was taken out of the mould.
- To ensure the best yacht performance at all times, clean the hull frequently only with a pressurized water jet. Never use sand paper on the hull!
- Remember that anti fouling paints contain toxic chemicals which can harm eyes, skin and lungs. When working on the hull always wear protective equipment and avoid direct body contact with the paint and solvents.

Interiors

- In case of damage to the paints, call Cantiere del Pardo for information.
- Keep the interior of the boat well ventilated and dry at all times.
- Avoid long time exposure of the varnish to direct sun rays by using curtains or canvases

Stainless Steel

- AISI 316 stainless steel is used for the hardware on the Grand Soleil 43'. This is a steel alloy containing the ideal percentage of molybdenum between 2 and 3% which is particularly resistant to corrosion and oxidation in marine conditions.
- This does not mean that this steel is not subject to chemical aggression such as chlorides, sulphates and ferrous contamination (more frequent in port areas than at sea), present in polluted environments.
- The marine environment and waters with a high concentration of chlorine ions tend to create “pitting” in stainless steel; this is the pitting corrosion which occurs initially with rust points on the surfaces and then penetrates the internal structure.



Maintenance

- To prevent or reduce pitting, never use detergent containing chlorine (e.g. hydrochloric acid and its solutions) or abrasives (iron pads, abrasive paper etc.) when cleaning stainless steel surfaces. These modify the surface passivity of the stainless steel and reduce protection.
- To clean stainless steel parts correctly, use a soft cloth, sponge or soft brush with a fresh water and neutral soap solution; in case of very stubborn dirt, use special stainless steel cleaners.
- After sailing, if possible rinse the stainless steel surfaces with fresh water.
- If the boat is laid up for a long period, clean the stainless steel surfaces and apply a coating of Vaseline oil.

Electrical System

On the Grand Soleil 43' the electrical system is divided in two separate networks supplied by:

- ◇ **12 Vdc (Direct Current)**
- ◇ **220 Vac (Alternating Current)**
- ◇ The main and individual controls of both 12 Vdc and 220 Vac are gathered on the Functions Panels, next to the chart table (*see page 7.5 and following*).
- ◇ For the positioning of the main components, please refer to diagram nearby.

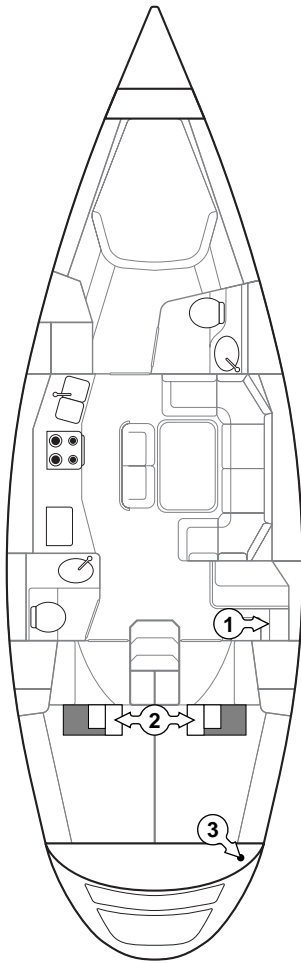

- 1 220VAC & 12VDC Functions panels
- 2 Batteries
- 3 220 VAC waterproof plug (in the cockpit)

12 Vdc network

- ◇ The 12 Vdc is the main one and it supplies:
 - engine starter
 - all services, except the 220 Vac supplied
- ◇ The 12 Vdc is powered by 3 batteries located below the double berths in the aft cabins on both sides.
- ◇ 2 batteries of 100 Ah each supply the servicing equipments whereas the other battery of 55 Ah is generally used only for the engine starter.
- ◇ By mean of a 3 ways switch (**1 - BOTH - 2**) located under the chart table on the right hand side you can select manually the service batteries only on position **1**, the parallel with the other battery on position **BOTH** or just the engine battery on position **2**.

Recommendations for 12 Vdc network



- Some services 12 Vdc are directly activated by Functions Panel switches; others are just powered on the Panel but to activate them the switch generally located near function must be turned on.
- To each 12 Vdc Functions Panel switch corresponds a L.E.D. which turns on when switch is engaged.
- The 12 Vdc voltmeter located on the top left corner of the 12 Vdc Functions Panel (see page 7.6) shows existing tension in the selected group of batteries.
- The Service Consumption indicator (Ammeter) located under the voltmeter on the same Functions Panel (see page 7.6) shows the amount of current (Ah) absorbed by the 12 Vdc system.

« Recommendations...

- The batteries are charged by the 12 Vdc alternator connected to the engine, or by the battery charger (opt) connected to 220 Vac shore supply.
- Check regularly on the indicators the data provided by the Voltmeter and by the Ammeter in order to keep the consumption under control and to intervene swiftly in case of malfunction.
- Make sure that battery terminals are greased and well fixed. The batteries should also be well strapped in their housing, with the help of anti-tipping straps.



12 Vdc System: the batteries

On the Grand Soleil 43', two 100 Ah batteries are dedicated to ship services and one 55 Ah battery is dedicated to engine starting. It is possible to connect them in parallel selecting the **BOTH** position in case of need.

- They are located under the berths of both aft cabins.
- They are contained inside acid resistant compartments and are easily accessible for maintenance and inspection.
- It is very important for the terminal connections to be clean and tight, the top side of the batteries should be dry and clean and the level of the electrolyte just over the inner led plates.
- A slight evaporation of water is normal and the batteries should be refilled every 4/5 weeks with distilled water.
- All the batteries on the GS 43' are rated for Marine Use
- These batteries are heavier in construction than the Auto Type batteries: they contain more lead and have a much larger active surface. Thanks to these characteristics they offer a better performance and reliability than Auto Batteries.
- Notwithstanding these characteristics, although designed for harsher use of long discharge periods and fast recharge cycles, all batteries have a limited life.
- The batteries' life is longer if the charge cycles are frequent and prolonged, with slower and gradual discharge cycles.
- Once a month, the batteries electrolyte should be tested with a hydrometer. By measuring the electrolyte specific density, you will find out how healthy the battery is. Proceed as follows:
 - The hydrometer consists of a large syringe of clear plastic that contains a color coded and graduated float.



« Batteries...



- Wear rubber gloves during the test as, in case of accidental spillage, the acid contained inside the batteries can be harmful.
- To obtain a reading, fill the syringe with electrolyte contained in each battery cell and read on the float the value of the specific density. The higher the float on the electrolyte level, the more charged is the battery.
- A value of 1.125 (generally marked in red) shows a state of discharge, a value around 1.135 (yellow) denotes an intermediate state of charge and a value of 1.260 (green) a state of maximum charge.
- Readings can be influenced by a number of factors including an elevated electrolyte temperature, which, because of expansion, would give a low reading even in a state of full charge. Cold electrolyte would cause the opposite effect. Best reading is between 18° and 20° C.
- When topping the cells with water, readings might be unreliable for a few hours: the added water might not mix readily with the denser electrolyte. Repeat the test after a few hours for true values.
- If, during the tests, you realize that one or more cells constantly show a lower value of charge than the others, it is very important to isolate and change the battery as soon as possible: it would damage the other batteries of the bank very rapidly.



12 Vdc sockets

- ◇ The 12 Vdc sockets are made in such a way that polarities can not be inverted accidentally and therefore only the corresponding plugs can be used.
- In the G.S.43' four 12 Vdc sockets are normally installed as follows:
 - Fwd head.
 - Galley
 - Aft head.
 - 12 Vdc electric panel

Fuses

- ◇ The anchor windlass push-button switch is protected by a fuse located inside the 12 Vdc electric panel.
- ◇ Each navigation light (red, green and white) is protected by an extra fuse located inside the 12 Vdc electric panel.

+

Magnetothermal switches

- ◇ The magnetothermal breakers located on functions panel have a twofold use:
 - activate the various functions
 - protect the function and its equipment.

Precautions for magnetothermal switches



Cable sections have been calculated in relation to power required by each function. Do not plug in supplementary by-pass charges on magnetothermal switch or replace it with one of bigger amperage.

- If a magnetothermal switches off, do not switch it back before locating the possible defect or short-circuit in the mains.

+

Opening the electric panels



The instructions about opening the electric panels are intended only for the technicians who will have to carry out the following operations:

- ◇ The electric panels are hinged on the bottom parts and can be opened by unscrewing the top screws.



- **Warning:** before opening the panels, make sure that the 220 Vac power is disconnected and that the plug is off, with the shore supply disconnected.

+



Instructions

- The magnetothermal switches here described can **directly activate** the various functions or just **monitor** them: in the first case by turning on the switch, the function will come on too; in the second case it will just pass on the power to a related switch generally located near the functions.
 - A l.e.d. will light up when corresponding function is on and is using or can use some current.

+

12 Vdc Control Panel

It is located near the chart table on the right hand side and is divided in sections described in English words. It includes all the 12 Vdc functions, the voltmeter and the ammeter.

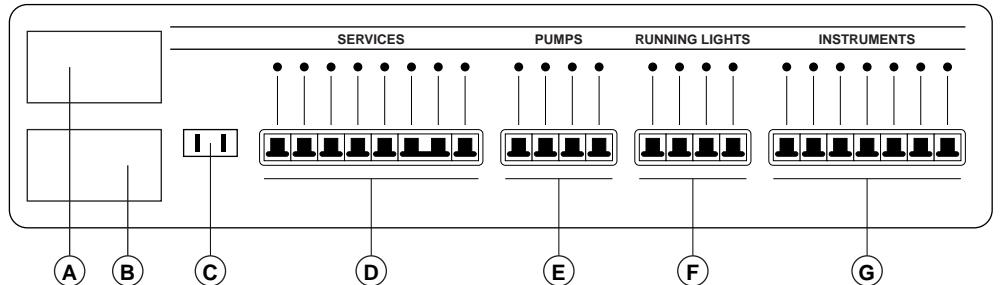

A 12 V DC VOLTMETER

by selecting manually the three ways selector near the chart table seat, it indicates the voltage of each group of batteries: **1** for the three service batteries, **BOTH** for all the four batteries together and **2** for the engine's one.

- With engine and battery charger off, the instrument must show at least 11.8 Volts. Should this figure drop below 11.2 Vdc, batteries should be immediately recharged. In any case never let the voltage drop below 10.5 Vdc.

B SERVICE CONSUMPTION (Ammeter)

indicates the value of the 12 Vdc current flow both in discharge (if any 12 Vdc appliance is on) or in charge (whenever engine or battery charger is on). When batteries are under charge, it will show a figure that is the result of the positive value of the charge minus the negative one of the consumption.

C 12 V DC (12 Vdc socket)

D SERVICES (Group of switches for the Services)

E PUMPS (Group of switches for the Pumps)

F RUNNING LIGHTS (Navigation Lights switches)

G INSTRUMENTS (Electronic Instruments switches)

+ Switches Group

D SERVICES

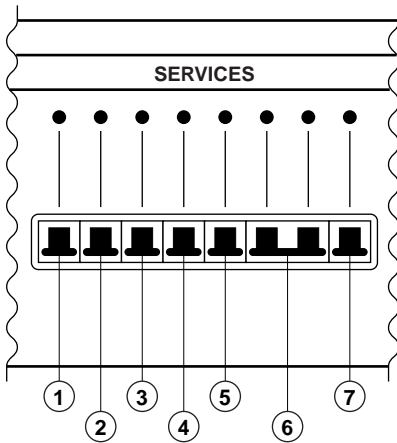

- 1 **STBD LIGHTS:** monitors all the interior lights of the starboard side.
- 2 **PORT LIGHTS:** monitors all the interior lights of the port side.
- 3 **FRIGOBOAT (Opt):** available to turn on the Frigo Boat refrigeration if installed.
- 4 **REFRIGERATOR:** turns directly on the compressor of the Frigomatic if the thermostat is already correctly set.
- 5 **12 V DC OUTLETS:** monitors all the 12 Vdc sockets.
- 6 **WINDLASS:** double switch (due to heavy electrical loads) that monitors the anchor windlass that can be then activated by push-buttons control in the anchor peak or by the 3 ways switch (Opt) on the engine panel in the cockpit.
- 7 Empty switch available for extra 12 Vdc appliances.

+ Switches Group

E PUMPS

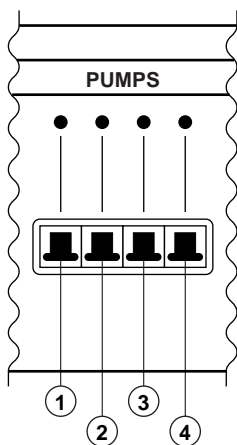

- 1 **BILGE PUMPS:** monitors the two pumps that empty the 6 bilges according to the position of the selectors located under the central seat in the saloon (selector “C”) or on the port side of the engine compartment (selector “D”). It’s important to remind that the actual activation switches are located in the heads area next to the sinks. For better information check the chapter “Bilge Pumps” at page. 5.1.
- 2 **FRESH WATER PUMP:** turns on the fresh water pump.
- 3 **DISPOSER:** available for extra 12 Vdc appliances.
- 4 Empty switch: available for extra 12 Vdc appliances.

+ Switches Group

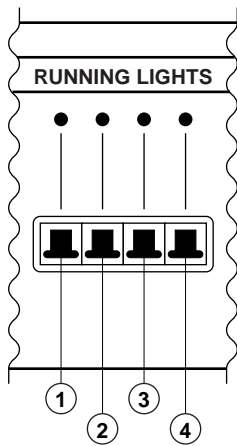

F RUNNING LIGHTS

- 1 **RUNNING LIGHTS:** turns on the navigation lights under sail (red and green on the bow and white astern).
- 2 **ENGINE LIGHTS:** turns on the white front light at mid mast compulsory while motoring at night.
- 3 **ANCHOR LIGHT:** turns on the white light on the mast top compulsory when anchoring at night.
- 4 **SEARCH LIGHT:** turns on the spot that flood-lights the fore deck and the bow.

+ Switches Group

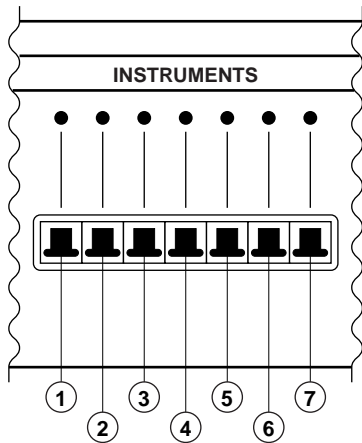

G INSTRUMENTS

- 1 **INSTRUMENTS LIGHT:**
turns on the lights of the compass' and of the water tank gauge's light.
- 2 **INSTRUMENT POWER:**
available for extra electronic instruments in front of the wheel in addition to those already powered by the AUTO PILOT switch.
- 3 **VHF / HI-FI:**
monitors the VHF radio (Opt) and appliances (Opt) such as Hi-Fi, TV etc.
- 4 **AUTO PILOT:**
turns on the electronic instruments (Opt) in the cockpit and the Auto Pilot (Opt). For more information about this one, refer to the chapter "Auto Pilot".
- 5 **GPS:**
monitors the GPS (Opt).
- 6 **RADAR:**
monitors the Radar (Opt).
- 7 **Empty switch:**
available for extra 12 Vdc instruments.

220 Vac network

◇ The 220 Volt AC system is powered by the an electrical cable connected to a shore power supply and the waterproof plug mounted on the stern of the yacht (see diagram).



Caution: Remember to rotate clockwise for half a turn the plug into the socket to activate the circuit.

◇ Remember that most dock outlets are equipped with an automatic safety switch that cuts the power off above 2000 Watts.

◇ From the aft socket, power reaches the main electrical panel through the 220 Vac blue breaker which includes a very sensitive “differential” circuit that automatically cuts the power off in case of the slightest short.

◇ From the differential breaker, the tension is measured with the 220 Vac Voltmeter (1) before reaching the circuit breakers on the main 220 Volt DC panel and the breakers.



220 Vac network cautions

- In spite of all the safety features built into the AC system (high sensitivity differential breaker), 220 Volt power remains dangerous.
- Precautions, and maximum care are necessary at all times around high voltage power.
- It is very dangerous to handle 220 Vac components, appliances or tools in a wet environment or with wet clothing or shoes.
- Always cut off power when you leave the yacht unattended.
- Check the aft socket for corrosion or leaks.
- Inside the yacht all circuits are protected both by the differential switch and breakers for all uses; but, between the aft socket and the shore, the circuit is protected only by the shore power breaker on the dock. Not all docks present adequate safety features. Take great care!!



Caution: Spikes or drops in the 220 Volt (nominal) power lines are frequent, especially in crowded marinas. Check for these variations by keeping an eye on the 220 Vac Voltmeter. The system is designed to withstand voltage variations up to +/-5% and will function properly only between these parameters. If the variations should exceed these values, disconnect immediately the whole electrical 220 Volt AC system by switching off the 220 Vac blue breaker.

+ **220 Vac Electrical panel**

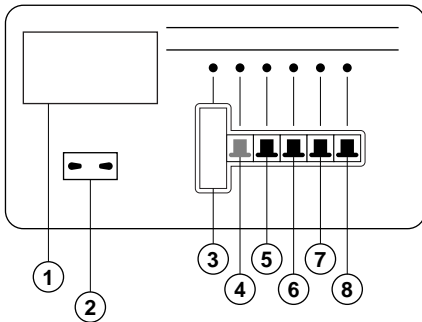

- 1 **220 V AC VOLTMETER**; shows the voltage of the alternating current flowing in the system.
- 2 **220 V AC**: 220 Vac socket.
- 3 **Main differential breaker**
- 4 **220 Vac “blue”**: this switch controls the main breaker monitoring all the 220 Vac system.
- 5 **220 V OUTLETS**: this switch monitors the 220 Vac sockets.
- 6 **BOILER**: this switch turns on the water heater. For further instruction check the chapter “Water Heater” on page 26.1.
- 7 **BATTERY CHARGER (Opt.)**: this switch turns on the battery charger. For further instructions check the chapter “Battery charger” on page 4.1.
- 8 **Empty switch**: available for extra 220 Vac appliance.

220 Vac sockets

- On G.S. 43', although other 220 Vac sockets (Opt) can be installed upon request, as standard feature there is only one 220 Vac outlet placed in the 220 Vac panel.



Water tank gauge

- Is located under the 12 Vdc electric panel and is activated automatically by turning on the “FRESH WATER PUMP” switch.



Caution: The gauge indicates the aft tank water level only as this one is generally used when the fwd one is already empty.



Fuel tank gauge

- Is located under the other gauge next to the chart table and is activated automatically by turning on the ignition key of the engine.

Engine: System and Mechanics

The following instructions do not replace the information provided in the enclosed Owner's Manual supplied by the Manufacturer.

- ◇ For details regarding the warranty, repairs, operation and maintenance of the engine, refer to the warranty booklet and the owner's manual supplied by the Manufacturer.
- ◇ Always quote the engine serial number and part number when ordering spare parts or requesting information from the Manufacturer.

Fuel System and Tank

For location of this system components please refer to the diagrams in this section.

- ◇ The diesel level gauge is located under the 12 Vdc Functions Panel and switches on automatically by turning on the engine ignition key (§ page 8.3).
- ◇ The tank filling cap is located in the cockpit floor facing the wheel, on the port side next to the aft water tank filling cap .
- ◇ From tank cap, the diesel oil flows through a pipe inside the tank which has a capacity of about 200 litres. This is made out of stainless steel and is located under the aft cabin berth on the port side.
- ◇ Linked to the tank, with the fuelling pipe, there are: a two-way pipe for engine supply, the vent-hole pipe (which ends on aft part of the port topside) and the location for an extra two-way pipe.
- ◇ In the upper part of the tank there is the stop cock of engine supply pipe which can be reached in through the hatch located below the aft port side berth. This cock can be activated directly or by a flexible control with a black handle, located in the aft peak of the cockpit on the starboard side.

- ◇ From the stop cock the diesel supply pipe arrives to the engine compartment and is connected to the fuel decanter in the front part of the engine and then to the filter on its top right part.

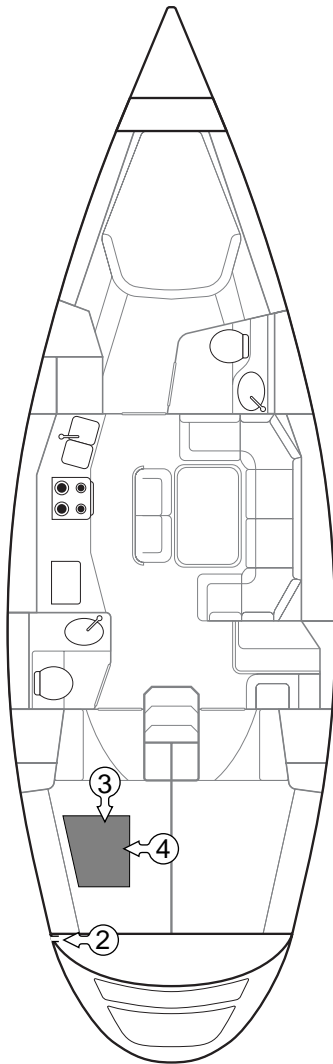

- 1) Deck fuel filling cap
- 2) Fuel tank vent.
- 3) Fuel supply stop cock.
- 4) Fuel tank.
- 5) Emergency fuel stop handle

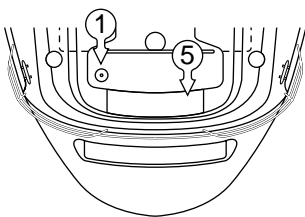

Recommendations and Precautions for the Fuel System

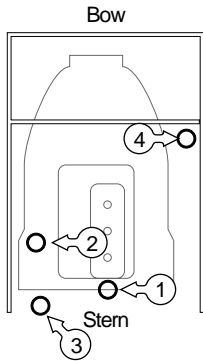

- In case of controls failure in the Engine Panel or an emergency (e.g. engine fire or leak in diesel system after the tank), the diesel oil flow can be interrupted by activating the handle located into the aft peak, or by activating directly the stop cock located on top of the tank.
- To open the flow again directly activate the stop cock over the tank.
- After using this cock, it could be necessary to bleed the system before starting engine. **The bleeding instructions are featured in "Use and Maintenance" booklet of the engine.**
- Unless strictly necessary, never stop the engine with the emergency cock.



Maintenance of the Fuel System

Engine compartment

- 1 Fuel decanter
- 2 Fuel filter
- 3 Sea water strainer
- 4 "No-return" cooling water siphon
- 5 Engine sea water sea-cock

- Replace diesel system filters of the engine in accordance with engine instructions booklet.
- When filling tank with diesel it is advisable to use a funnel fitted with a sieve.

Engine Water Cooling System

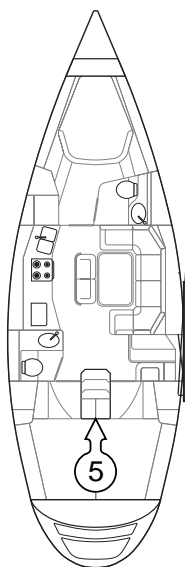

- ◇ The engine cooling system is sealed and is a fresh water indirect type with sea-water cooled heat exchanger.
- ◇ The sea water comes in through the valve located on the "S" drive transmission. It is accessible by lifting the casing cap located in the aft cabins at berths head.
- ◇ It then flows down to sea water strainer located on the front part of the engine compartment.
- ◇ From sea water strainer the water flows into engine sea-water heat exchanger: for further details refer to use and maintenance manual.
- ◇ A spigot connected to the stainless steel goose neck of the engine cooling sea water ends in a drain in the port topside of the hull in the aft peak. In this way the spigot "opens" the system preventing water return into the engine.
- Check that "Engine sea water inlet" cock is open before starting the engine and that, once started, the outflow is regular (§ diagram of this page).



Maintenance

- Clean frequently the sea-water strainer according to engine use and how clean sailing water are.
- Regularly check the proper operation of air inlet valve linked to engine spigot. Clean or replace it if need be.
- For engine maintenance please refer to the enclosed builder manual.

Engine Panel, control lever and engine cutoff push button.

The engine dash-panel is at the right hand side of helm wheel and includes instruments, lights and other functions.

- ◇ Below it there is the single lever gear control.
- ◇ On the right of engine dash-panel in the lower part there is the engine cutoff red push button.

Engine electrical panel

- 1 Anchor windlass switch (Opt)
- 2 Rev. counter
- 3 Temperature alarm
- 4 Oil pressure alarm
- 5 Alternator alarm
- 6 Engine hours meter
- 7 Panel illumination switch
- 8 Ignition key
- 9 Engine STOP push-button

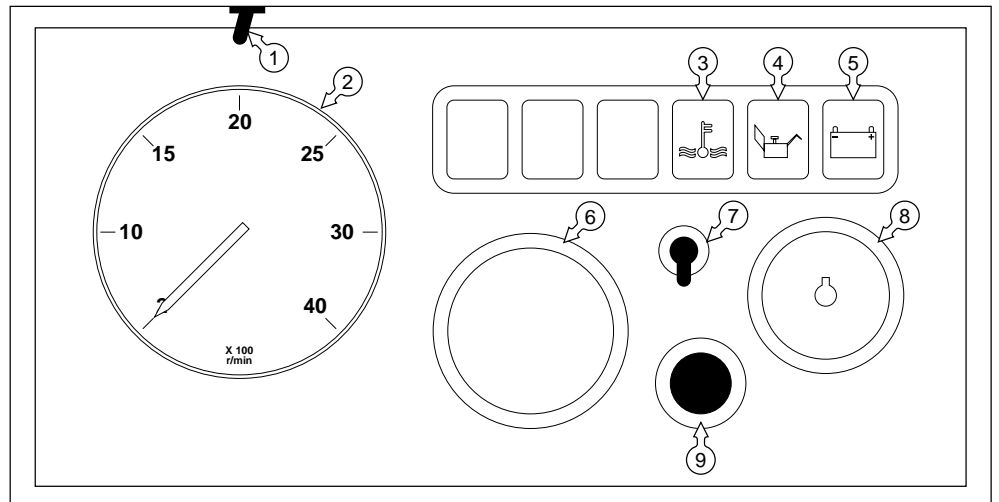



Instructions

Single lever control

Single lever control

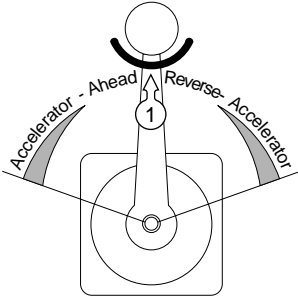

1 Neutral push-button

• This hand lever may be used as an accelerator as well as a gear control according if you push it forward (ahead motion) or backward (astern motion). It is fitted with a top handle to be used as follows:

- When lever is upright, pull the top handle to get into neutral; kept in this position either pushing the lever ahead or backward you will only increase the engine revs.
- Bring lever back upright: the top handle will slide down, back in gear; pushing forward or backward the lever, you will engage the gears and increase engine revs. in ahead or reverse motion.

Cutoff engine button

• It is activated by the big red push button located on the right in the lower right side of the engine dash-panel. By pushing it, the engine stops.

Anchor windlass switch (opt)

• Controls anchor winch action if the double switch in the 12 Vdc panel has been previously turned on. This control (Opt) is in addition to the bow push-buttons switch.

- For further information on anchor winch please refer to page 2.1

For description and instructions regarding the controls panel please refer to engine instructions booklet.



Engine starting

The following indication do not replace the engine manufacturer's instructions contained in the Owner's Manual



The engine is cranked by a 12 Vdc starter that gets the electric power by both engine and service batteries according to the position of the 3 ways manual batteries selector located near the chart table sit.



Instructions for engine starting

Before starting engine, especially after an inactivity period, check cooling fluid and both engine and gear box oil levels. Proceed as follows:

- Connect batteries turning the 3 ways switch located under the



chart table (right side) to position "2" (engine battery). In case of low charge, use position "1" (Services) or "BOTH" (Parallel).

- Open sea water inlet of engine cooling system located on the "S" drive transmission on the rear of the engine (§ diagram page 8.2).
- With the single lever upright, pull up the top handle (see page 8.4) and push the gas control hand lever onto approx. 1/3 of the accelerated position.
- Turn clockwise the ignition key to "on": the lights of engine panel will come on.
- Keep turning ignition key to activate engine starter till "Start" position: as soon as the engine runs, let the key return to "On".
- Before getting into gear and get moving, keep the engine running in neutral at approx. 1200 revs. for about 10 minutes.
- Once started, check that engine cooling water flows out regularly through exhaust pipe on port side.
- After the engine has started and reached the working temperature, throttle down gradually until lever is vertical again: the top handle will slide down allowing to shift into gear.

Running-in

- Refer to the instructions' manual supplied by the engine manufacturer.
- Do not push engine to peak R.P.M. rate for long stretches of time especially during the first 25 hours of navigation.
- When cold, do not push engine to its limits. After the engine has run a few hours (as indicated in use and maintenance manual) contact the builder's engine assistance service for the first overhaul.



Engine shutdown



- Throttle down and let the engine run idle at minimum revs for few minutes to decrease temperature.
- Throttle down to the minimum by pushing the lever back into the upright position.
- Turn off engine by pushing the STOP red button.
- Once engine has stopped, turn off ignition key.

+

- Switch **OFF** the parallel between services batteries and engine battery **BOTH** by positioning the 3 ways switch located below navigation table either on **0** or on **1** (service batteries).
- If you leave the boat unattended for long time, turn off sea-water inlet of engine cooling system, located on the “S” drive (§ to page 8.2).



General Recommendations and Precautions for Using the Engine



- Read engine use and maintenance manual, and in case of doubt, please contact the builder’s assistance service.
- Do not keep engine running in case of heeling (lateral boat inclination) of over 20°.
- Never turn off batteries parallel switch on **0** when engine is running.
- Never switch **OFF** the ignition key when engine is running.
- Check all levels before starting engine, especially after month-balling.
- Regularly check that there are no leaks in all systems: cooling water, diesel fuel, engine and transmission oils.
- Regularly check cooling water pump; repair immediately if it slightly leaks.
- Often inspect engine cooling water strainer. If need be, clean it after having turned off the seacock of the sea-water inlet on the “S” drive (§ to page 8.2 & page 22.1).
- Regularly check the clear fuel filter and replace both filter elements when needed according to the included manual.
- Regularly check oil filter condition (see included manual).

+

+



Gear box

For maintenance and inspections regarding the gear box, please refer to provided manual.



S-Drive rubber gasket

+

Pay maximum attention not to punch or damage it and read the included manual attentively.

Exhaust

- ◇ The exhaust consists of a special rubber manifold that runs under the port side aft cabin berth and connects the engine to the plastic muffler and then to the plastic no-return siphon (both of “Vetus” type).
- The plastic siphon is located just before exhausts off board and is reachable through aft port side peak.
- Refer to included manual.



Access to engine



On board the Grand Soleil 43' the engine can be reached from the stairway, from the aft cabins and from both sides as follows:

- By lifting the main entrance stairway.

Accesses to engine

- 1 Engine front access
- 2 Engine access from aft cabin
- 3 Engine lateral accesses

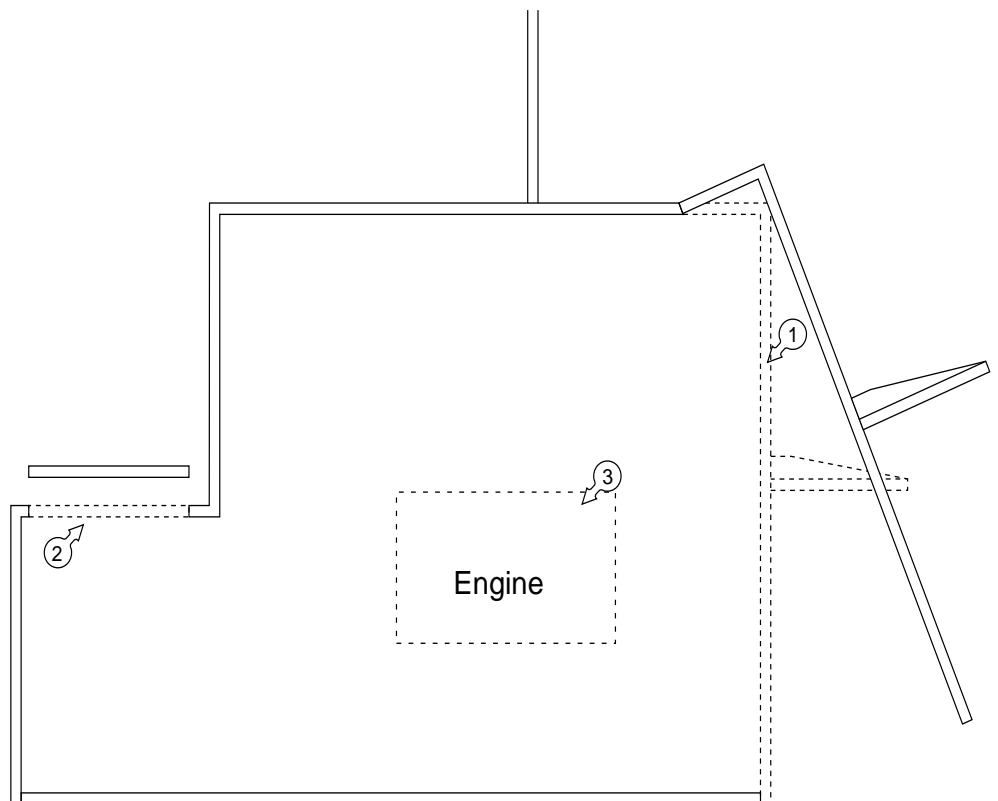

+

- By opening the side panels in the aft cabins.
- By lifting the case lids in aft cabins at berth head you can reach the engine sea-water inlet, the gear box oil deep stick, the sea-water strainer.
 - Never touch the engine or transmission parts when engine is running.



Ventilation of engine compartment

On board the Grand Soleil 43" there is a natural engine ventilation system.

- ◇ The air intakes for engine compartment are on the outer side of the cockpit edge, abaft, near 220 VAC aft socket. From engine compartment air is then conveyed through a pipe whose exhaust is near air intake.

+

Precautions in respect of the engine compartment ventilation

Caution: Make sure that the air intakes for the system are free and clear from obstructing objects.



- In case of fire inside the engine room, promptly stop ventilation of the compartment by clogging the vent with towels, clothes or cushions.

+

+

Galvanic protection

The Grand Soleil 43' is equipped with the following anti-corrosion anodes, protecting the metal parts exposed to galvanic currents.

◆ **on the "S drive" propeller shaft**

◆ **on the main engine** (*ref. to the Engine Owner's Manual*)

◆ **in the water heater** (*ref. to the Water Heater Owner's Manual*)

The anodes must be carefully controlled as follows:

Propeller Shaft

The propeller shaft anode is exposed more than any other to galvanic currents. It is fitted on the shaft itself, in front of the propeller.



- It should be checked each time the boat is hauled out and at least 2 or 3 times during the season.
 - If the anode shows more than 30% loss of volume, replace it as soon as possible. In order to assess the degree of corrosion, compare it with a new anode.
- The same precautions should be applied to the propeller anode.

Main engine

Refer to the engine manufacturer owner's manual for the location and care of the main engine anodes.



- Replace as needed.

Water heater

Refer to the manufacturer owner's manual for the positioning and care of the water heater anodes.



- Replace as needed



General recommendations

- If one or more anodes corrode rapidly, this may indicate possible electrical dispersion or may be due to the proximity of big conductive masses (such as large motor yachts or ships) in water with a high salinity gradient.
 - Have a qualified marine electrician checking the electrical system and eliminate dispersions or install removable, dockside anodes.

Genoa furler

The following recommendations do not replace the information provided in the furler's manufacturer Owner's Manual.

- ◇ The Genoa furler is a gear which makes it possible to furl this sail around the fore stay quickly and easily. The relative control line is led to the cockpit for easy use.
- ◇ With the furling gear it is possible to sail with the Genoa partially reduced: remember that in this case the windward performance is considerably reduced with respect to the performance obtained with a regular jib of the proper size and weight. Remember that the weight of the cloth and the smaller surface of a furling Genoa reduce the performance of the yacht also in light breezes with respect to the performance obtained with a standard Genoa.

The furling Genoa is especially designed for this purpose with UV protection, special reinforcements and polyurethane lining;



Instructions

In order to reduce the load on the furling line as much as possible, follow these guidelines:

- take up on the backstay to avoid excessive sag of the forestay which could interfere with furling;
- ease the Genoa sheet to spill at least 3/4 of the wind out of the sail during the operation;
- make sure that the spinnaker halyards or other halyards are tight and securely fastened at the foot of the mast to avoid jamming during furling.
- When you unfurl the sail by releasing the furling line, remember to apply a light friction on it: if you let this line go too fast you will cause overrides on the drum.



Maintenance

- Replace the furling line as soon as it shows any sign of wear, even several times during a season if necessary.
- The bearings and the other parts of the furling gear must be rinsed frequently with fresh water according to the Manufacturer's Recommendations.

+ **Genoa furling system**

5 Furling line block

8 Furling line fairleads

19 Genoa furling line

+ 26 Furling line stopper

*NB the above numbers correspond to the
general deck fittings diagram at page 11.2*



**Always consult the Furling System
Owner's Manual supplied by the
Manufacturer.**

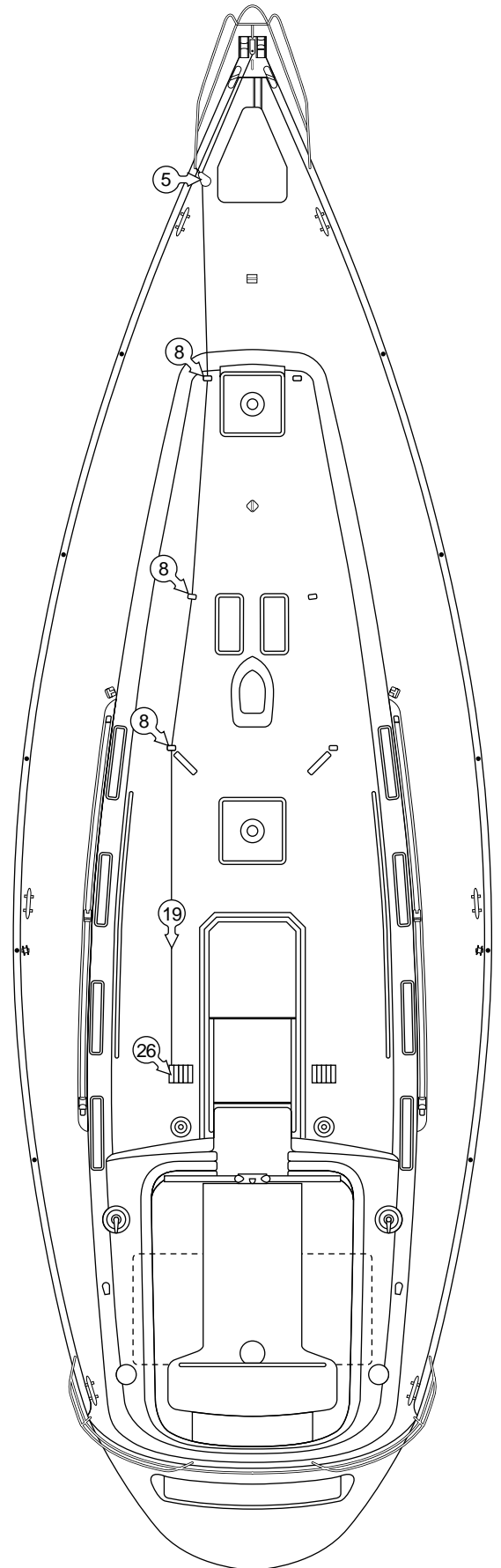

Deck Hardware and Fittings

The deck hardware and fittings mounted on the Grand Soleil 43' are of the highest quality available.

The hardware and steel works are made in AISI 316 stainless steel, the best for marine application. They are mirror polished and protected with special packaging during the entire production cycle.

Identification of Deck Fittings

If detailed identification of the deck fittings is required, refer to the part identification # stamped on the parts and contact the manufacturer.

Functions of the Deck Fittings

The diagram on next page illustrates the function of each component.



General Maintenance

Notwithstanding its name, stainless steel is subject to oxidation and corrosion without proper maintenance: marine conditions and the environment can damage the material without proper maintenance. The same applies to all other metal fittings on deck such as turnbuckles, blocks, tracks, toe rails etc, including all anodized aluminum fittings .



Refer to Chapter 6 on Bright works for full details on maintenance of the metal parts (page 6.3).

+ **Deck Hardware and Fitting: diagram**

- 1 Anchor chain roller
- 2 M.P.S. eye-bolt
- 3 Mooring lines fair lead
- 4 Anchor windlass
- 5 Furler line block
- 6 Mooring cleats
- 7 Spinnaker pole downhaul eye-bolt (Opt.)
- 8 Furler line fairlead
- 9 Spinnaker pole downhaul fairlead (Opt.)
- 10 Babystay chainplate
- 11 Halyard pin-rack
- 12 Shrouds chainplates
- + 13 Genoa track
- 14 Halyards organizer
- 15 Spinnaker pole topping lift (Opt.)
- 16 Mainsail second reef
- 17 Mainsail first reef
- 18 Mainsail halyard
- 19 Genoa furling line
- 20 Genoa halyard
- 21 Mainsail base line
- 22 Mainsail sheet
- 23 Spinnaker halyard (Opt)
- 24 Spinnaker boom downhaul line (Opt)
- 25 Spinnaker foreguy blocks (Opt)
- + 26 Halyards stoppers
- 27 Halyards winches
- 28 Mainsail traveller
- 29 Mainsail traveller cleats
- 30 Genoa sheet winch
- 31 Genoa sheet block
- 32 Compass and instruments (Opt)
- 33 Steering wheel
- 34 Liferaft peak
- 35 Spinnaker sheet blocks' eye-bolts
- 36 Emergency tiller insert
- 37 Backstay chainplate
- 38 Swimming ladder

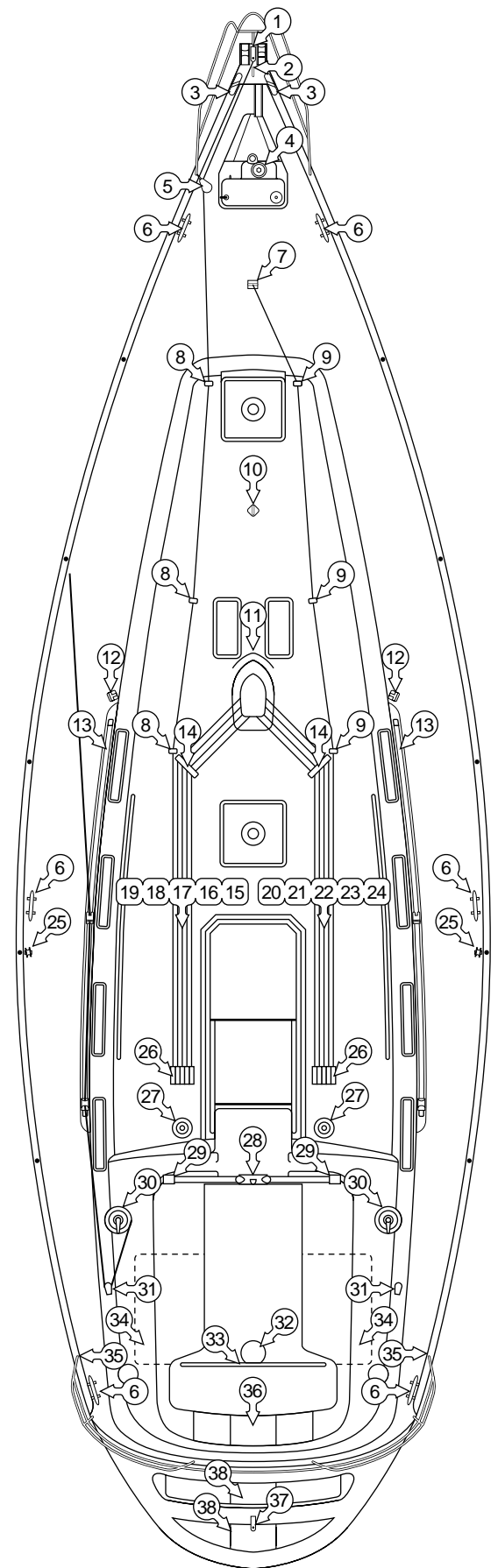

+

+

Running rigging

On the GS 43' halyards and sheets are made of pre-stretched textile fiber.



Regular maintenance

- Check frequently for halyards, sheet or lines' wear and change them in case of damage evidence.
- When hoisting a sail, take care of pulling up slowly the last few inches of sail and by keeping the sheets reasonably slack. The halyard could be damaged by jumping the sheave, which could be also damaged by the sailhorn shackle.
 - to this purpose we recommend fitting standard nylon stops to the halyard ends to protect the splices and prevent them from entering the sheave housings.
 - we also recommend that you to mark the point of maximum hoist on all halyards at the winches' end.

+

+

+

+

RUNNING RIGGING HALYARDS	TYPE	LENGHT (ml)	Ø (mm)	COLOR		TERMINAL
				Line	Border	
Mainsail sheet						
Genoa furling line						
Main outhaul						
Reef 1						
Reef 2						
Genoa hall. 1						
Genoa hall. 2						
Spinnaker hall. 1						
Spinnaker hall. 2						
Staysail hall						
Running Backstays						
Spinnaker pole t. lift						

+

RUNNING RIGGING SHEETS	TYPE	LENGHT (ml)	Ø (mm)	COLOR		TERMINAL
				Line	Border	
Mainsail sheet						
Genoa roller furler sheet						
Mainsail traveler (nr. 2)						
Genoa sheet (nr. 2 x)						
Spinnaker sheet n°1 (Opt) n°2 (Opt)						
Spinnaker after guy (Opt)						

+

- *We recommend that you fill out the blanks with the informations concerning your vessel*

+

Hatches and Portholes

The layout of the hatches and portholes from the bow, is as follows:

- ◇ 1 large deck forepeak (anchor chain).
- ◇ 1 large hatch for the fore cabin.
- ◇ Twin hatches for fore cabin and head.
- ◇ Main salon hatch.
- ◇ Main sliding companionway.
- ◇ 1 opening portholes on Galley (port side).
- ◇ 2 portholes in main saloon and chart table (stbd. side).
- ◇ Porthole aft head.
- ◇ 1 porthole in each aft cabin on cockpit side.
- ◇ 1 hatch in each aft cabin on top deck.

The G.S. 43' can also be equipped with one "dorade" box wind-hose (Opt) installed on deck in front of the main sliding companionway.

Recommendations and Precautions

! Always keep to the following safety measures when using the hatches and portholes:

- When not on board, lock all hatches and portholes.
- Never leave a hatch top open at an angle of more than 45° with the deck line: this will allow adequate ventilation without the risk of someone tripping and falling inside.

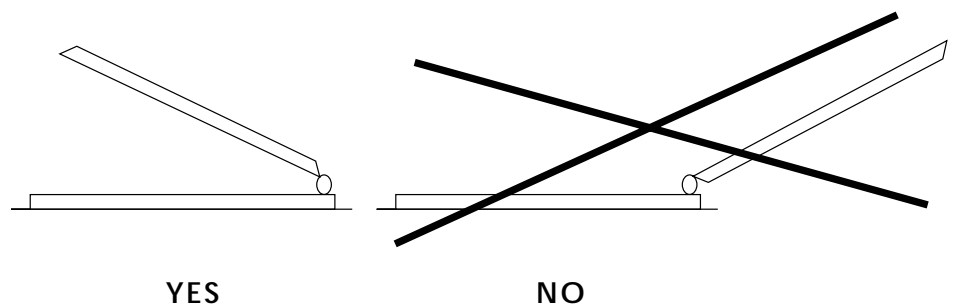

- To avoid hinge damage, open hatches gradually and without excessive force following all the settings of the hinge mechanism.

- When the hatch is open, never place your fingers, hands or feet on the edges.
- Avoid walking on the Plexiglas surface of the hatch: it may be slippery if wet or damp. We recommend you to apply anti skid tape on the surface.
- While sailing, if not properly closed, hatches can create problems letting in water. Always remember to:
 - close down all hatches when sailing, especially the fwd hatch which can take in a great deal of water in a very short time since it opens towards the bow;
 - in bad weather ensure that all levers and screw knobs are well secured.



Important: While all the hatches open outwards, the portholes open inwards to ensure ventilation; remember to be careful when they are open since they are mounted at face level.



Maintenance

- Before opening the portholes, take care to dry all water that might be resting outside in the porthole recess.
- Wash the hatches frequently with fresh water and, whenever needed, grease up the rubber gasket with Vaseline or clear silicon grease.
- If the hatches do not remain open into position, check the hinge mechanism and adjust as necessary the special deep-set hexagonal screw on the hinge itself.

Notice: Take care not to position the slings on the propeller shaft, it's strut and the log housing

Haulout

The Haulout of a yacht of the size and displacement of the Grand Soleil 43' is a delicate operation that should be performed only in proper facilities by specialized personnel.

Lifting

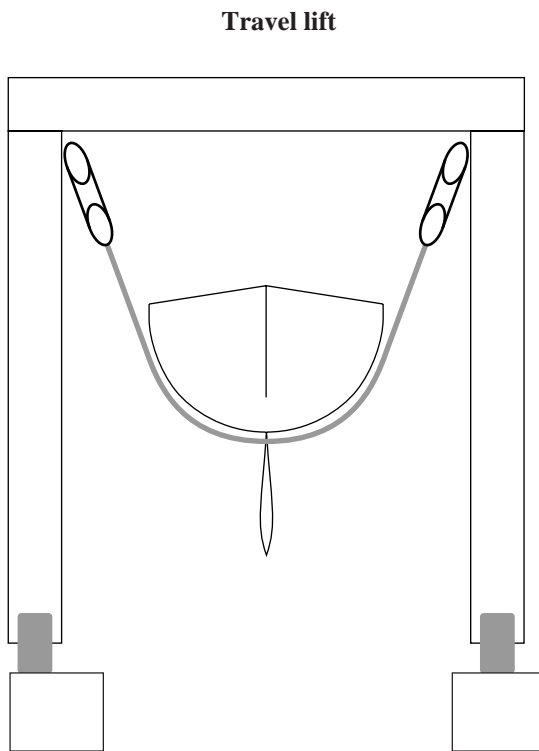
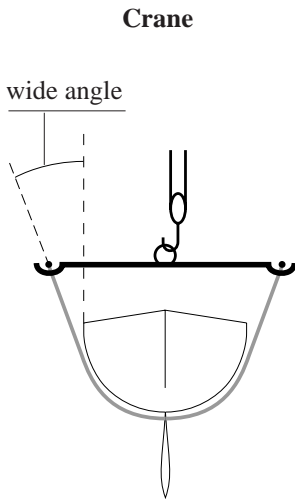

◇ To haul the 43' it is necessary to use a travel lift of appropriate lifting capacity and span.

◇ An alternate method, in the absence of a travel lift, is through the use of a crane which must be equipped with a large spreader. This **must** be wider than the deck to avoid excessive pressure on the deck, caprail, lifelines and stanchions.

◇ Before the haulout a few preliminary operations should be carried out:

- Wash and wrap the lifting slings with packing plastic to avoid scratches to the hull caused by the dirt trapped in the sling fibers. This operation is particularly important on hulls with blue gel coat which is more delicate than the white ones.
- Make sure that the slings will not slide fore or aft from their position.
- Pull the log transducer (Opt.) inside the hull (see page 18.1).
- Make sure that the slings will not damage the "S drive" of the propeller shaft (which is located approx. under the mainsail traveller), the echosounder and the log housing.

+ **Lifting slings position**

For a well balanced lifting of the Grand Soleil 43', position the slings as follows (see diagram):

- **Fore sling:** 20 cm. aft of the second stanchion from the bow.
- **Aft sling:** 30 cm. fwd. of the last stanchion from the bow.

- 1 Foreward sling
2 Aft sling

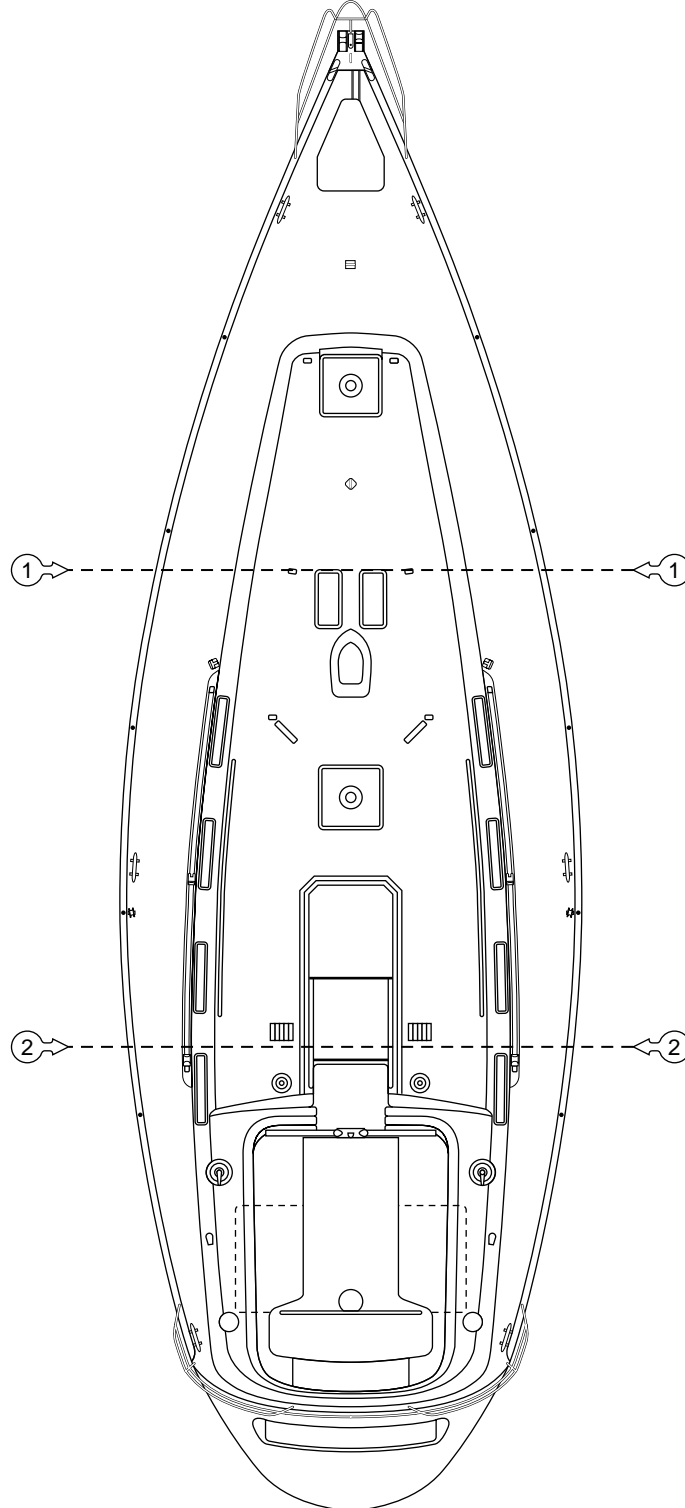

+ **Δ Important**

These positions are valid only if the yacht's trim is correct and within the parameters established by the Cantiere del Pardo.

All modifications and changes in the loading of the yacht may cause changes in the position of the slings.Δ

+ **Notice:** Take care not to position the slings on the propeller shaft, the echosounder and the log housing

Mast

The mast is stepped directly on the yacht bottom through a metal mast step.

- Standard and extended (opt) masts are rigged with two orders of spreaders; racing (opt) mast is rigged with three orders of spreaders. We are going to refer to this last version being the most complex one.

Stays

On the longitudinal plane, the standard mast is sustained by Forestay, Babystay, and Backstay. . The Inner Forestay (Opt) and the Running Backstay (Runners, Opt) can be installed as an optional although they are not strictly necessary as the spreaders and the shrouds are set at an angle toward the stern of approx. 8 ° that helps to sustain the mast.

General guidelines for mast tuning

Cantiere del Pardo has designed the mast for the GS 43' to the highest standards of safety and performance. Nevertheless, it is very important to follow the instructions provided in this chapter because the incorrect use of the tuning devices for the standing or running rigging can lead to excessive loads on the mast and structures.

While sailing upwind, it is very important to control the mast camber keeping an eye on the *pumping* (rhythmical longitudinal bending) of the rig.

It is recommended to always keep a slight tension on the Baby Stay, especially if the pumping of the mast is particularly strong in a formed sea-way (state 4 or up).

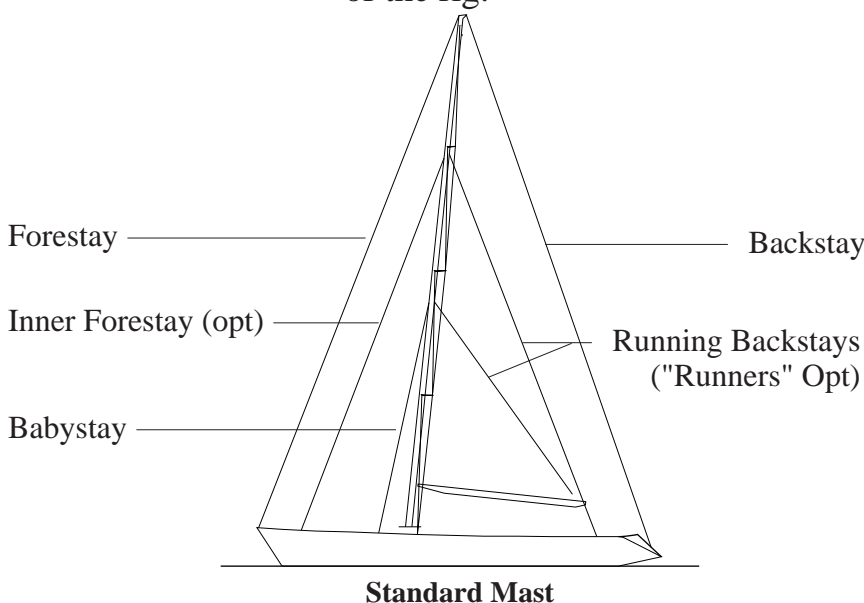

Standard Mast

Tuning

The stays must be tuned to reduce and stop the longitudinal pumping of the mast and, at the same time, allow the right amount of camber to the mast.

From the mast collar on deck to the top of the mast, the mast camber must have a maximum chord of 15 cm.. For the mainsail roller furler rig (Opt.), the maximum chord should not exceed 10 cm. especially during the furling and unfurling of the mainsail to avoid unwanted strain and wear on the sail bolts and leach.



Mast camber

The natural bend of the mast (*exaggerated in the diagram*) must be even and regular.

From the mast collar on deck to the top of the mast, the maximum chord must not exceed 10÷15 cm

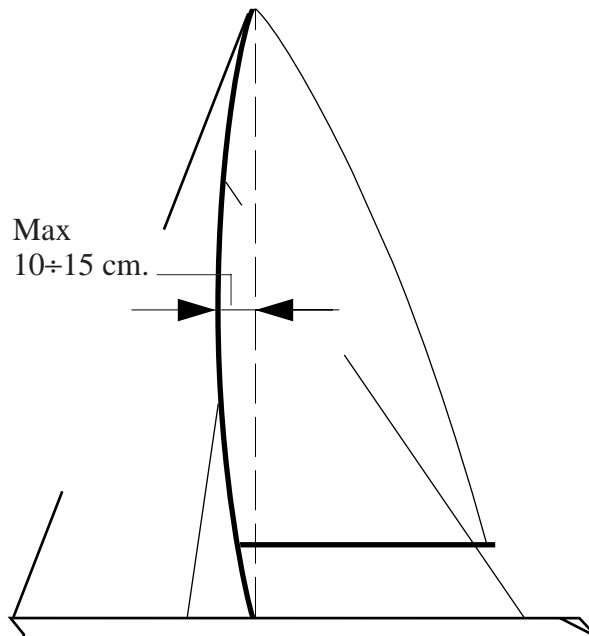

Please note that “*tensioning*” the rig does not mean stressing the rig. The stays only need to block the mast’s oscillations caused by its inertia and should not be overstressed.



Recommendations for the tuning of the Babystay and the Inner Forestay (Opt)

The Baby Stay and the Inner Forestay (opt) could easily over bend the mast if slightly overstrained: be therefore very careful not to exaggerate in hauling them taut. See diagram.



Wrong pull of the babystay
Do not over bend the mast with the babystay

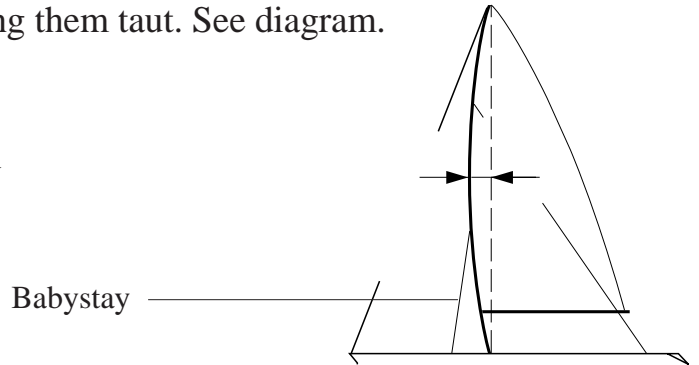

Backstay

The backstay tension should be increased while sailing to windward in relation to the strength of the breeze to reduce the forestay slack: the stronger the wind, the higher the pull.

- While running, reduce the backstay pull just enough to avoid excessive forestay slack.
- Remember that when you release the back stay you should also release the runners (Opt). Excessive runner (Opt) tension may cause the mast to invert its curvature and be permanently damaged. All back stay adjustments must be matched by runner (Opt) adjustments.

Inner forestay (Opt.) and Runners (Opt.)

If installed, with heavy seas and strong breeze it's necessary to haul taut the inner forestay and the luff runner. We supply as Optional runners with blocks and stoppers in case of aft runners' lines. They should be led to spi winches (Opt.).

Shrouds

On the lateral plane, the standard mast is supported by a discontinuous system of spiroidal shrouds named Diagonal (D) and Vertical (V) and numbered progressively from bottom to top. the spreaders and the shrouds are set with an angle toward the stern of approx. 8° that helps to sustain the mast.

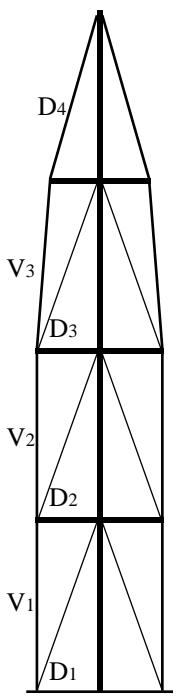

Standard Mast

Tuning the shrouds

On the lateral plane, the mast should be as straight as possible under load. You can check this by looking at the mainsail track from the bottom up.

At the time of delivery, the yacht's rig is properly tuned.

After a few weeks of use, though, the rigging will be subject to "creep", or slight stretching.

It is important to check periodically for "creep" and tighten the shrouds accordingly, acting on the relative turnbuckles.



These very small adjustments should be **always performed on leeward shrouds.**

- Whenever, for any reason, a complete check and tuning of the rig for safety or performance should become necessary, we strongly recommend you to contact the Cantiere del Pardo or specialized technicians.



Recommendations for the tuning of the standing rigging.

The complete tuning of the rig should be performed only by experienced personnel.

- The following checklist should be used whenever a complete tuning is necessary.
 - With the yacht at the dock, with no sails hoisted, slacken the runners (Opt) and babystay (Opt.), and make sure that the forestay and backstay are barely in tension.
 - Take all slack out of the shrouds by evenly tightening all turnbuckles
 - The mainsail track should, at this point, be very straight.
 - Tension the vertical shrouds (V) **evenly** by taking two or three complete turns of the turnbuckles. The mainsail track should be kept straight.
 - Tension the diagonal shrouds maintaining the straightness of the mast.
 - Load lightly the mast by sailing in close hauled on a medium light breeze and flat sea in a protected area to verify the lateral mast alignment with medium-light tension on the stays.
 - Tension all diagonals so that the mast is straight on the lateral plane. The tensioning of the shrouds can be accomplished safely only on the leeward shrouds: if you want to correct the mast's lateral bend while sailing for example on starboard tack,

« Recommendations...

you will have to tack to port, work on the starboard shrouds and tack again to check your work.

- The tensioning of the diagonal shrouds should be very gradual (one turn at a time) since too much tension could add compression to the mast thus increasing the bend instead of decreasing it.
- It might happen that the mainsail track looks straight, but in effect the mast is slightly leaning on a side. The symptom of this situation is usually a better performance to windward on the relative tack. In this case check the distance from the top mast to chainplates with the main halyard: the measurement must be the same on both sides.
- In the event that the vertical shrouds (V) should need more tensioning it will be necessary to slacken all diagonals by about one turn before taking up on the Verticals since V1 will tension all other shrouds. At this point the D shrouds should be tensioned again to align the mast as described above.
- After completing these operations, all pins and stops of turnbuckles should be reinstalled and taped.



Mast maintenance and periodic checks

- Check frequently for halyard wear.
- When hoisting a sail, take care in tensioning slowly the last few inches of sail and by keeping the sheets reasonably slack. The halyard could be damaged by jumping the sheave or by breaking for excessive load.
 - to this purpose we recommend fitting standard nylon stops to the halyard ends to protect the splices and prevent them from entering the sheave housings.
 - We also recommend that you mark the point of maximum hoist on all halyards.
 - Check the condition of the shrouds and stays frequently, especially near the terminals and splices. Even the smallest pitting or crack could be extremely dangerous.
 - Always check for broken wires: even if only a single strand is broken, replace the shroud immediately.
 - Check periodically for cracks or deformation at the spreaders or shrouds connection on the mast..
 - Make sure that when you tension the shrouds, enough of the thread is screwed into the turnbuckles: an amount of male thread equal or greater than the diameter should be inside the female.



« Mast maintenance ...



- Check periodically that there is no water infiltration through the mast boot at deck level.
- Check the padding of the spreader tips is in order to prevent sail chafing and tears.
- Rinse the turnbuckles and halyard leads, blocks and stoppers frequently with fresh water.
- Avoid covering the turnbuckles with plastic piping or adhesive tape since they prevent evaporation and increase salt buildup.

Recommendations for the stepping and unstepping of the mast.



These operations should be carried out only by specialized technicians. The following guidelines are intended as a memorandum for them.

The stepping and unstepping of the GS 43's mast is a delicate operation. Great care and attention must be taken to avoid injury to people and damage to the yacht and rigging. Never stand or walk under the suspended mast or the radius of the crane. These operations must be carried out in absence of waves and wind in a protected area using suitable equipment.

Follow these guidelines for the unstepping of the mast:

- Remove the sails
- Disconnect the vang and the boom from the mast joint and carefully place them on deck.
- Check that the passage of the mast is unobstructed by wires or pipes. Disconnect all electrical wires and electronic cables at the junction boxes taking care of labelling them clearly to later facilitate the reconnection.
- All pipes and electrical cables must be positioned and held into place to avoid pinching and damaging during the lifting of the mast through the deck.
- Make sure that the lifting sling is in good condition, appropriate for this operation and solidly attached.
 - It should be placed above the mast's centre of gravity so that the mast will naturally be hanging in a vertical position.
 - Normally the sling should be placed just under the upper spreaders.
- Tie two lines at the lower spreaders ends: they will work as "bridles" to guide the mast through the operation.
- At this point, after slightly loading the lifting sling, the shrouds

+ << Stepping and
Unstepping...

and stays can be slackened and disconnected from turnbuckles. All their cotter and coupling pins must be taped on in place to facilitate reassembling.

- All shrouds, stays and running rigging must be securely tied to the mast to avoid bending and over stressing during the operation. This is particularly important for all rod components and especially for the Genoa furler.
- Lift the mast rubber collar by pushing it from below decks.
- The mast is now totally held by the crane and can be lifted with great care. Once in the air, it may be moved to an appropriate place and carefully lowered and laid horizontally on at least four “horses” taking care not to pinch any part of the rigging or wiring. All antennas and wind indicators must be removed and protected.

+ To step in the mast follow these directions in reversed order.

Halyard exits on the mast

The following drawing illustrates the correct exits on the mast foot for halyards and other running rigging components.

- Use it as reference when stepping the mast or replacing a halyard.

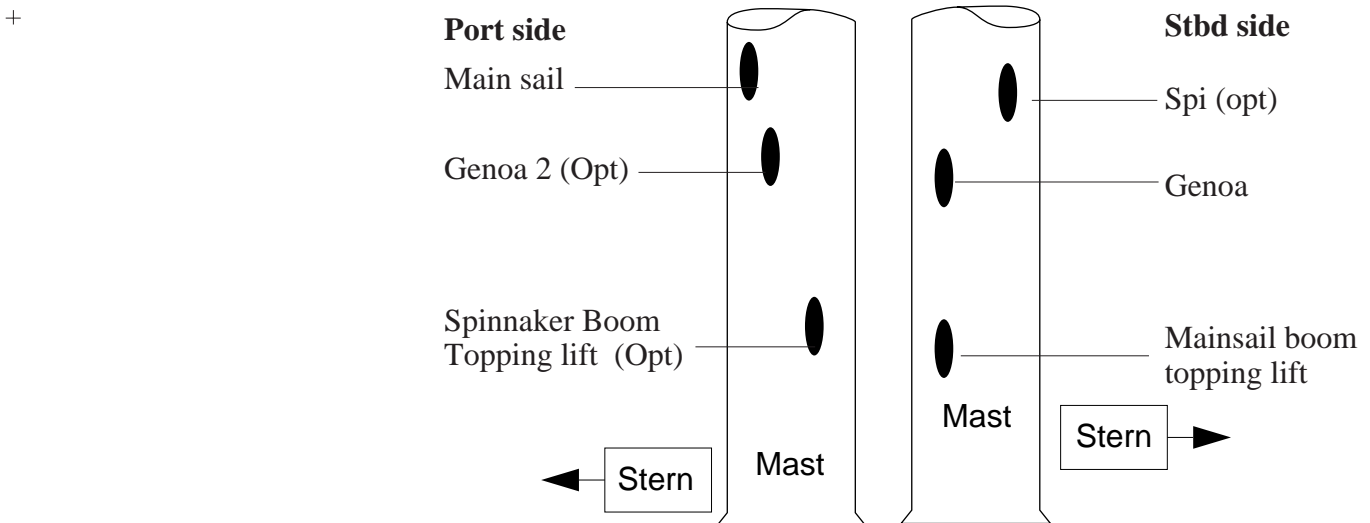

Navigational Instruments

All the navigation instruments, except the compass, are optional. Some general information is given on the most commonly used instruments.

Always read the Owner's Manual supplied by the Manufacturer for all the instruments installed on board.

Compass

◇ The yacht is equipped with a standard compass mounted in the binnacle on the wheel pedestal.



- **At delivery, the compass is not adjusted.**
- Remember to have the compass adjusted by a qualified compass adjuster when all the other fittings and instruments have been installed.
- Keep portable radios, torch-lights, tape-recorders, cameras with built-in exposure meter and other instruments containing batteries or metal objects such as pots etc. away from the compass since they strongly affect the magnetic field of the compass.

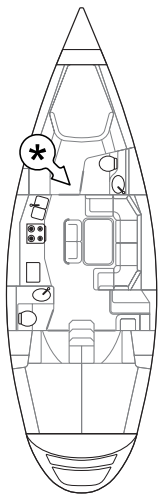

Instruments Electrical Supply

- The electric power supply of the various instruments is activated by the magneto-thermal switches in the 12 Vdc Service Panel: for more information refer to page 8.5

Depth Sounder Transducer (Opt)

- The Depth Sounder Transducer is located right in front of the mast step, under the floor boards of the fore cabin and is accessible through a bilge well.

Log Transducer (Opt)

- The Log Transducer is located in the front of the mast step, on the left of the Depth Sounder Transducer, with the same access.
- When the log is not used, and especially when the yacht is left unattended for a long period of time, the transducer should be pulled-up to avoid damage caused by floating objects, dirt and growth.



- Remember to pull-up the log transducer before haul out.

* Location for Depth Sounder (Opt) & Log Transducers (Opt)

+

Mast Head Units and Aerials

- The masthead connections of the VHF antenna cables and the wind direction mast head unit should be checked at least once or preferably twice during the season, or every time you work on the masthead.
- If the electrical contacts are corroded, oxidized or badly connected, the instruments will not function efficiently.
- Corroded or oxidized contact surfaces should be cleaned and sprayed with a contact-cleaner (e.g. CRC).

+

+

+

Propane gas system

See diagram at page 16.3

- ◇ One 3 Kg. propane bottle is installed in a special compartment in the cockpit area under the helmsman seat and has an independent drain on the port top side.
- ◇ The system is equipped with a regulator with an automatic cut off valve.
- ◇ The bottle is connected with an approved flexible hose clamped in place to the copper piping that reaches the galley area. The piping runs along the hull on the port side of the yacht and ends into the stove compartment with an interception valve.
- ◇ An approved flexible hose, clamped in place, connects the copper pipe to the stove allowing it to swing on its gimbals.



Stove Lighting Instructions

To light a burner:

- Open the valve on the propane bottle in the cockpit locker.
- Open the interception valve behind the stove.
- Choose the appropriate burner and light it up keeping the knob pushed for a few seconds to warm up the safety thermo couple valve.



Caution: The safety thermo couple valve, after a few years use, might deteriorate and need replacing by specialized personnel.

Caution



- The system contains propane gas under pressure that can be dangerous in case of leaks.



- All open flames, especially propane stoves, must be used with extreme caution.



- All open flames may ignite fires on board the yacht.
- When leaving the boat unattended:
 - close the valve in the galley compartment, behind the stove;
 - close the valve on the propane bottle in the aft cockpit.



Maintenance and periodical checks

- When in port or in flat water, secure the pivoting stove in the horizontal position.
- Check the condition of the flexible hoses and of the clamps securing them to the copper pipes. Replace immediately with approved gas hose at the first signs of cracking or wear.
- Check that all clamps are tightly fastened.
- Have qualified technicians periodically test the system.

Propane smell

- Whenever you smell propane inside the yacht, immediately shut off the interception valves in the cockpit and the galley compartment. Immediately ventilate the vessel by opening hatches and portholes avoiding all open flames, cigarettes, sparks etc.
- The system should be checked by a technician. If this is not possible, proceed as follows:
- Make a solution of 1/3 liquid soap and 2/3 water and spread with a brush over all connections. In particular:
 - Connection between bottle and flexible hose
 - Connection between hose and copper piping
 - Connection between copper piping and interception valve in galley compartment
 - Connection between interception valve and hose
 - Connection between hose and stove



Caution: Development of foam or bubbles in these areas denotes leaks.



Never use open flames to check for propane leaks!

- Propane is heavier than air and will collect in the bilge.
- Ventilate the bilge if a leak is spotted avoiding all open flames, cigarettes, sparks etc.

Changing a propane bottle



Caution! The substitution of a propane bottle is a delicate operation. Great care must be taken to avoid the presence of all open flames, sparks and cigarettes.

- Close the valve on the regulator.
- Unscrew the empty bottle while holding the regulator unit.
- Screw the new bottle firmly in place by hand, making sure that the threads are clean and in good order.
- Open the safety valve on the regulator unit.
- We recommend to store the second (and the eventual third) spare propane bottle in one of the two lateral peaks of the cockpit in a way that they will not be able to move or roll around even in rough sea conditions.



Carefully read the owner's manual provided by the stove manufacturer.

Propane system

- 1 Bottles and Regulator
- 2 Hose
- 3 Interception valve

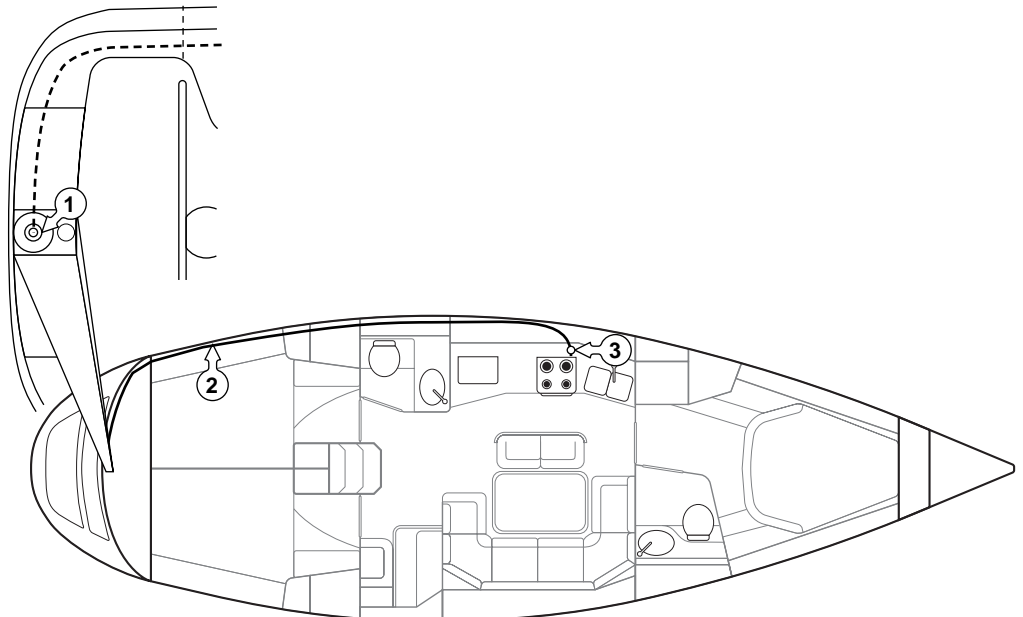

Propeller

◇ The standard propeller for the 40 Hp engine is a three fixed blades type.

Diameter	Advance
16"	13" left-hand



Recommendations

- Never allow the propeller to turn freely while sailing.
 - If the propeller keeps on turning while sailing, this means that the forward gear is not engaged and you should therefore engage it.
- During normal engine use, always wait several seconds to allow the engine revs to drop to idling speed before changing gear. Changing gear too abruptly can in fact damage the propeller and engine mechanisms.
- Always consult the Manufacturer's technicians before changing the propeller pitch, regardless of whether it is a fixed or folding propeller (Opt): an incorrect pitch can strain or damage the engine.



Reefs

The boom of the Grand Soleil 43' is fitted to house three reef stoppers to take in 3 reefs, and moreover it has a base-spreader for Main sail base adjustment.



Instructions

- From the pulley located on the far rear end of the boom, the end of the reef line runs into the clew of the reef you want to take.
 - From the reef hole it then runs aside the boom and is fastened to the corresponding eyebolt under the boom.

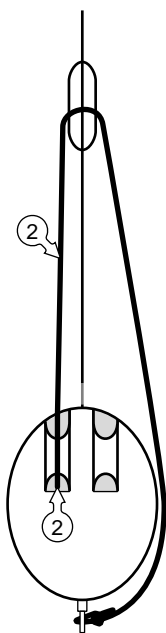

— Att view —

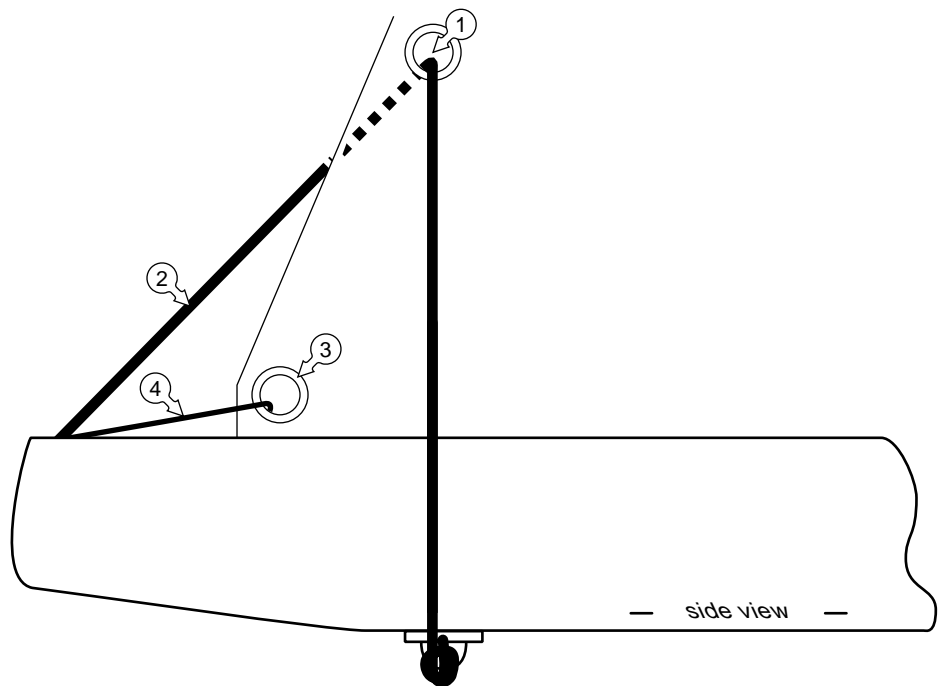

— side view —

- The other end of the reef line is sent back to the cockpit on one of the sides of the deck house (to determine which side, refer to deck fittings diagram page 11.2), to the stopper and then the deck house winch (§ page 11.2).
- The reef tack point is hooked to one of the two hooks on mast boom binder.

Mainsail reefs

- 1 Reef clew.
- 2 Reef line.
- 3 Mainsail clew.
- 4 Mainsail base line.
- 5 Reef tack hook.
- 6 Reef line pulley.
- 7 Reef line going to the winch.





Taking in a reef

Once the reef line has been installed, do as follows to take in reefs:

- Whether the boat is fitted with a stiff boom vang (opt) or with a tackle one, always release a little the sheet of the main sail before commencing the operation, as for any other sail.

With stiff boom vang (opt)

- The boom is propped by the vang itself.

With tackle boom vang

- Do as usual, so draw boom topping lift tight to hold it up.

Then:

- after having released the main sail halyard and opened the sliding blocks catch on the mast, hang reef tack point to one of the hooks located on boom binder on the mast.
- Haul taut the main sail halyard again.
- Haul in the reef line with the winch located on the deck house. When the operation is completed, release the winch by shutting the reef stopper on the deck house (see page 11.2).
- Release boom topping lift, adjust the tackle or stiff boom vang (opt) and haul in main sail sheet for normal navigation.
- If you reef sail for a long time, tie up the extra main sail section with gaskets onto the boom. This operation must be always carried out if you take in 2 or 3 reefs when there will be too much extra cloth hanging on the boom.



Letting out a reef

- Release a little the main sail sheet so that the boom will not be held back while operating.
- If the boat is fitted with a tackle vang, draw boom topping lift tight in order to hold it up while releasing vang tackle.
- Carefully open the halyard stopper: to do it, you must first haul in the line with the winch and then open the stopper.
- Slightly release main sail halyard to release reef tack hole. Run the free slide blocks on their mast slot and then place back the stopping pin.
- Release the reef line while hauling in the main sail halyard until the manoeuvre is completed.
- Adjust main sail sheet and boom topping lift and vang for normal navigation.

+

« Lettin out a reef ...



Caution: the third reef (Opt) has no stopper on the deck house and therefore it will be sent back to the available winch, unless you decide to take out one unused and run the third reef line into that stopper before the manoeuvre.



Warning notices and advice

- Taking in a reef is very important as far as safety while navigating is concerned. This calls for an important coordination among the crew members and before starting it is advisable to determine each crew member's role.
- Before sailing, it is advisable that the crew practice taking in reefs on a regular basis.
- And this must be highlighted particularly if some crew members are not familiar with sail handling.
- Taking in a reef should be done in bad weather or just before. It has to be done swiftly especially out in the Mediterranean, where weather conditions can change suddenly.
- When you start sailing, it is advisable to have at least one reef handy and already run into the clew of the reef.
- If you are sailing at night, it is highly recommended to have at least one reef ready before sunset.

+

Messengers

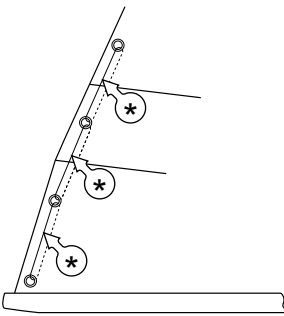

- In order to avoid that some crew members climb dangerously on the far aft end of the boom, before hoisting the main sail run small messenger lines into reef clews as follows:
 - a messenger between main sail clew and clew hole of the first reef.
 - a messenger between the clew of the first reef and that of the second one.
 - a messenger between the clew of the second reef and that of the third one.

+

* Messengers to facilitate the setting of the reef lines through the clews.

When you want to take in a reef, just tie up the end of the reef line to a messenger: by pulling the latter the reef line will automatically run through the hole. This will spare crew members very hazardous acrobatic feats.

+

Refrigeration system

The following indications do not replace the information given in builder's manual.

- ◇ The refrigerator unit is positioned in the aft section of the galley.
- ◇ If not fitted with a Frigomatic and/or Frigoboat appliance (opt.), the fridge compartment can be used as an icebox.
- ◇ The unit is reachable through the top by lifting the lid.
- For the identification and the layout of the components described under this heading, please refer to diagram on page 19.3.

Frigomatic Appliance

- ◇ The equipment allows for a 12V DC electrical refrigerator.
- ◇ The fridge installation consists of:
 - a 12 Vdc self driven electrical compressor cooled by an internal fan, positioned below the locker under the aft head's sink;
 - a refrigerating plate in the fridge compartment;
 - a thermostat inside the fridge.
- The **REFRIGERATOR** switch is positioned on the 12 Vdc Functions Panel. (§ 7.6).
- It is activated by the thermostat inside the fridge compartment. Once adjusted to the wanted temperature, do not use the thermostat as a fridge switch, this function being carried out with the switch positioned on Functions Panel.
- ◇ The installation has been designed with a view to optimizing the functioning of the system. It is obvious that a slightly superior consumption will occur at the beginning of the operation, before reaching wanted temperature.



Precautionary notices



- Do not deposit any object in the area where the compressor is: this may damage it and would cause a ventilation drop for a regular cooling.
- When putting bottles and foodstuff in the fridge, take particular care not to damage the metallic tubes connected to the cooling plate.



- **Pay attention not to store any heavy or sharp objects in the small locker under the fridge and to handle with care anything you place there as the pipes and the joints of the cooling system can easily get damaged.**

« Caution

Frigoboat Appliance (opt)

- ◇ On the Grand Soleil 43' is possible to install a mechanical compressor "Frigoboat" (Opt) connected to the engine.
- It is driven by the engine and it is positioned in its front part.
- Half an hour run at about 1200 rev. twice a day should be sufficient to reach and maintain the right cooling temperature.

Other installation components

- ◇ The temperature adjusting thermostat is positioned inside the fridge compartment.
- ◇ The condenser and the filter of the Frigoboat (Opt) are inside the engine compartment.
- ◇ A hole in the lower part of the fridge unit collects condensation water; this water is drained out through a clear pipe positioned in the compartment under the refrigerator.



Maintenance

- Check frequently that the drain hole of refrigerator unit is clear and empty the draining pipe; than close back the valve of the fridge drain to avoid loss of cold and uncontrolled spillage of the condensation water in the bilge.



- To avoid foul odours, the inside of the fridge must always be very clean.



- When the boat is left unattended for a long time and the fridge is not running, it is advisable to leave the unit lid ajar for ventilation.



- In case of poor cooling of the plates and every two or three years anyhow, it is advisable to call in a technician to check and if need refill with proper gas the cooling system.

- The Frigoboat (Opt) does not need particular care: yet is advisable to check frequently the driving belts located in the fore part of the main pulley in front of the engine.



We advise to read the owner's directions and maintenance manual given by the manufacturer.

+ **Refrigerator system diagram**

+

Refrigerator components

- 1 Cooling plate
- 2 Thermostat
- 3 Compressor
- 4 Condensed water drainage

+

+

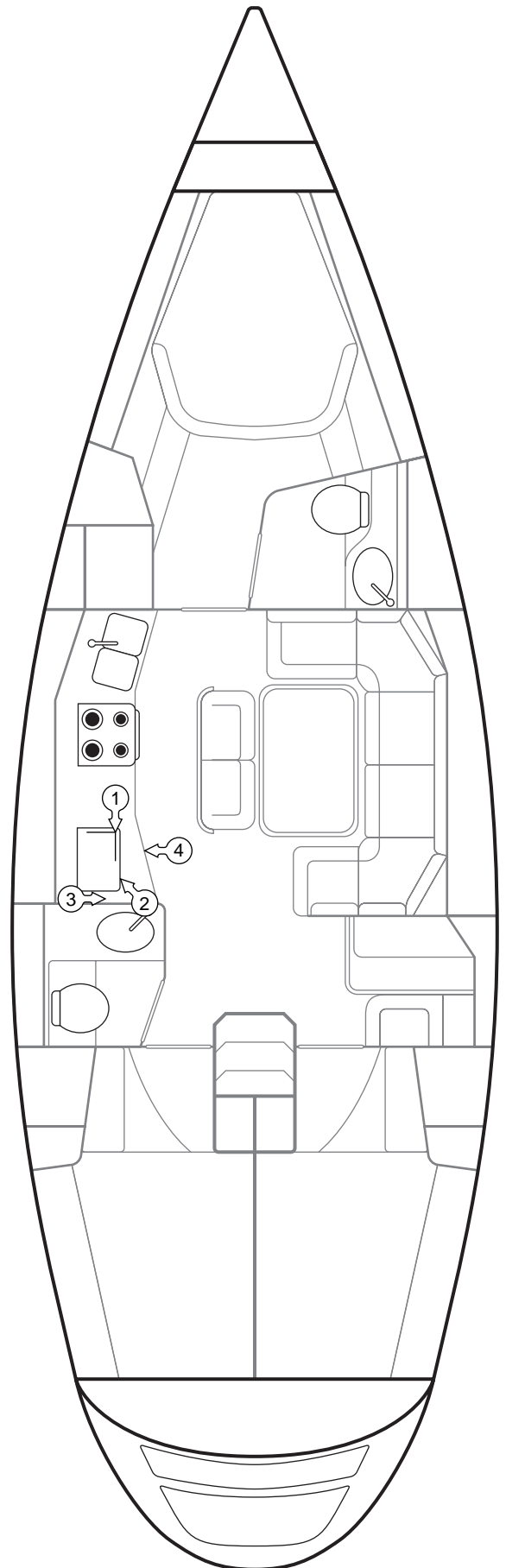

Rudder

The rudder has an elliptical shape and is suspended; the stock is made of stainless steel while the blade is made of fiberglass and is reinforced with a stainless steel frame welded to the stock.

Bushings and Bearings

The stock is supported and guided by two points as follows:

- ◇ **at the bottom:** by a self aligning delrin bushing in an aluminum housing anchored to the hull with fiberglass stratification and located above the water line.
- ◇ **at the top:** by a self aligning delrin bushing and bearing.

Steering Gear Elements and Cables

- ◇ Transmission of the movements of wheel to the rudder is as follows: the wheel transmits the movements to a chain fitted with two steel cables at its ends, through a pinion located in the steering pedestal.

Steering Gear Cables

Side view

- 1 Wheel
- 2 Wheel stopper
- 3 Pulley
- 4 Rudder stock
- 5 Bearing
- 6 Sector
- 7 Rudder
- 8 Emergency tiller cap

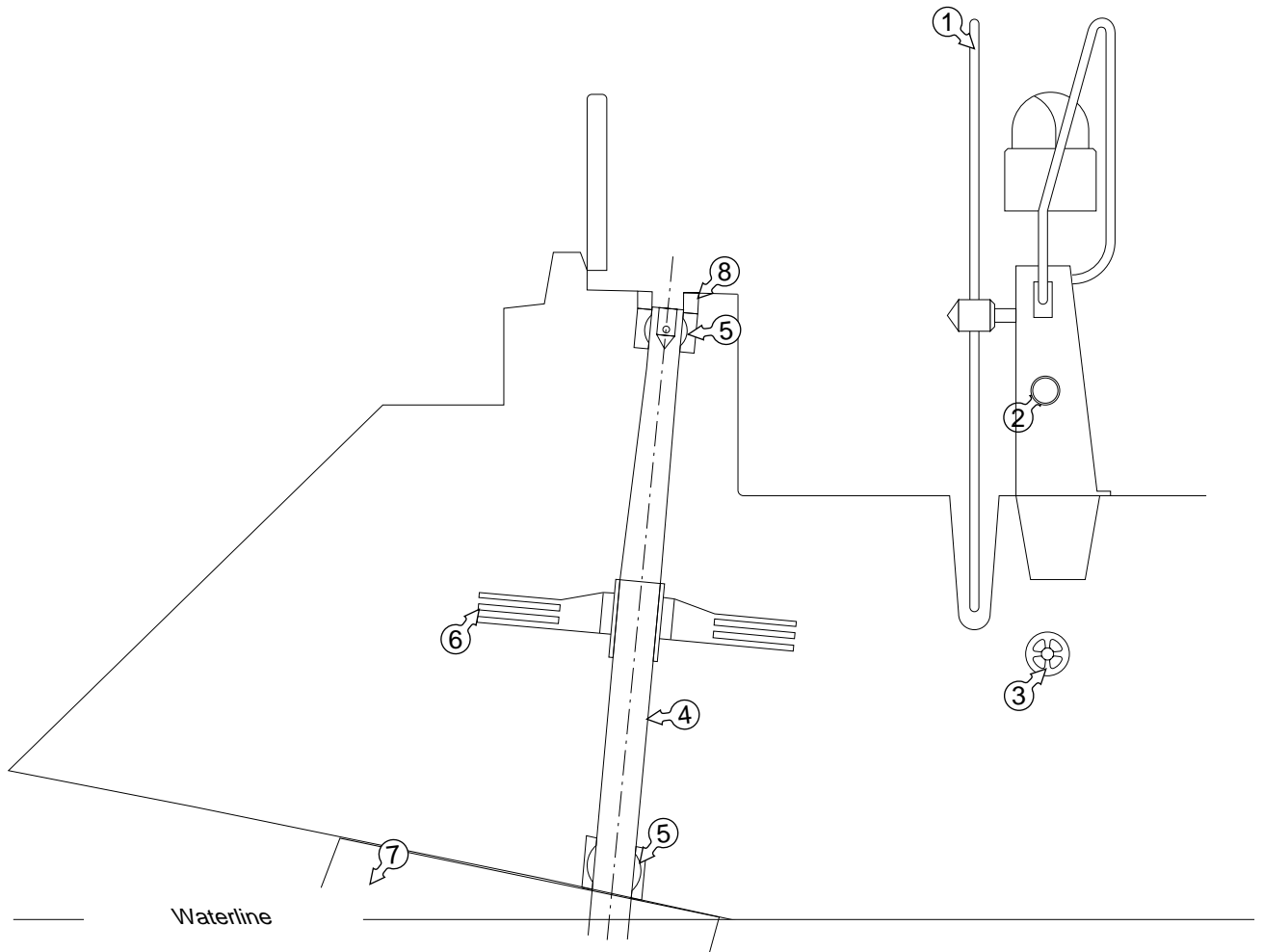

- + ◇ These cables run through two pulleys located at the foot of the pedestal and are connected to the quadrant which is fixed to the steering stock with bolts. The cables are secured to the quadrant by means of two adjustable bottlescrews.
- ◇ A knob is fitted on the steering binnacle to lock the rudder wheel.



Precautions for Steering Cables

- + • After the first few days of sailing you must adjust the steering cables: if they are too slack they must be tightened with the special adjusting bolts located at the end of the steering cables.
- The cables should be tightened just enough to take up all slack.
- + • Check periodically the alignment of the pulleys and cables: when the sheaves are worn at the edges this means that there is some misalignment and you should call in a qualified technician.
- Grease the steering cables periodically with silicone grease.



Maintenance of the Steering Cables

We recommend to:

- + • Check the tension and the wear of the cables frequently. In the case of slack, correct this immediately.
- Replace cables at the slightest sign of wear.

+

+

Access to the Steering Gear Elements

Access for inspection and repairs to the steering gear, is from the aft peak of the cockpit and from the aft section of the aft cabins.

Instructions for Installing the Emergency Tiller



In case of failure of the steering gear transmission system, use the special emergency tiller which is mounted as follows:

- fit the special coupling of the tiller on the upper edge of the stock located under the central seat of the cockpit next to the propane tank; the lower part of this coupling has been shaped so that it matches perfectly.
 - Insert the tiller
- If the boat is fitted with an (opt) automatic pilot, this may also be used as an alternative steering system.
 - Practice installing and steering with the emergency tiller.

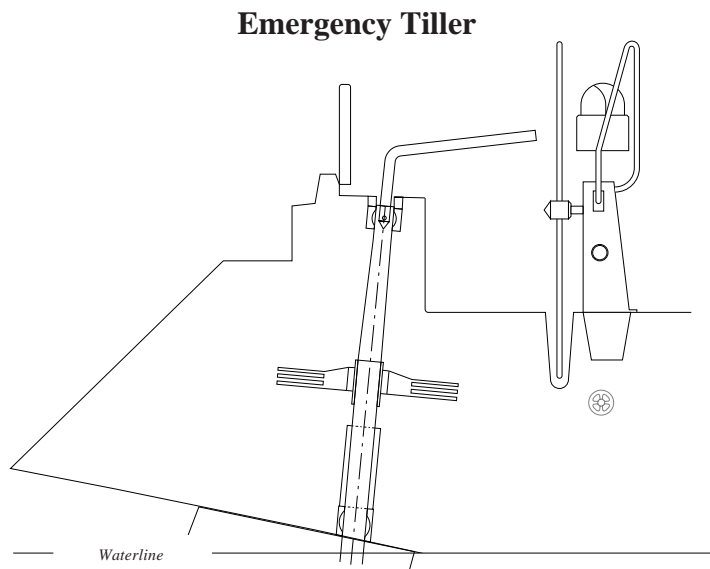

Sails

The standard sail equipment of the Grand Soleil 43' provides:

◇ **Main sail**

◇ **Furling Genoa**

Regarding the necessary measurements when ordering sails, please refer to Technical Data on page 1.1.



Warning notices

- Ultraviolet rays and prolonged shivering are the main factors causing sails aging. Therefore, it is advisable to:
 - Protect the main sail with a cover (opt) whenever it is folded away and left on the boom.
 - As the boat features jib furler, the genoa is designed and reinforced in this view. The ultraviolet-resistant fabric strip is sewn onto foot and leach sides, protecting the genoa when entirely coiled up.
 - Avoid shivering the sail too long and avoid motoring upwind too long with the mainsail on.
- The genoa base is particularly subject to wearing and ripping: it is therefore advisable to check that the pins and the spindles to stays and stanchions are directed toward the opposite part of genoa chafing. Protect them with grey tape or leather.
- Also the genoa chafing against spreaders is one of the main cause to ruptures and rippings of the sail.



It is thus advisable to:

- to protect with tape or leather the end of spreaders which have to be inspected regularly.
- in coincidence with the spreader arms chafing, apply on the genoa self adhesive sail cloth. Better to let the same sail maker do that!



Maintenance

Regularly check the following:

- doublings and sailcloth seams;
- clews, heads and tacks;
- genoa and mainsail leach and luff lines;
- batten pockets and mainsail head.
- Regularly wash the sails with fresh water, especially after rough conditions.
- Before putting the boat out of commission for the winter or mothballing, wash, thoroughly dry and fold the sails away carefully and store in a dry and dark place.

Sea Cocks and Drains - Summing up

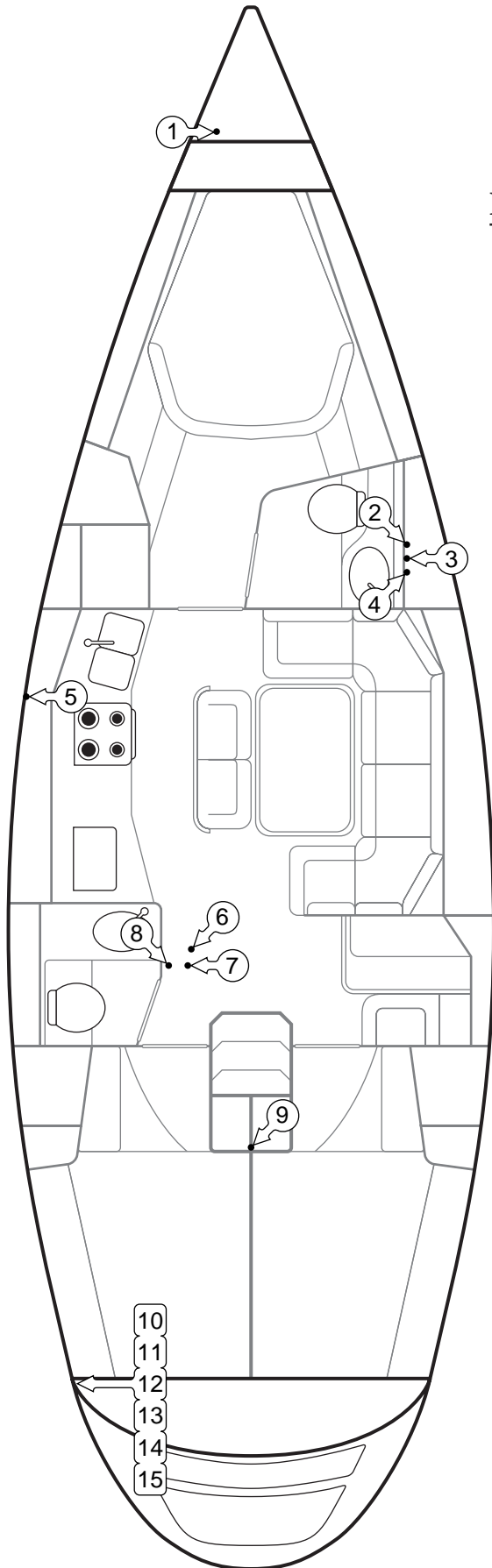

Locations

- 1 Fwd water tank vent
- 2 Fwd toilet water intake
- 3 Fwd head sink discharge
- 4 Fwd toilet discharge
- 5 Galley sink discharge
- 6 Aft toilet water intake
- 7 Aft head sink discharge
- 8 Aft toilet discharge
- 9 Engine water intake,
- 10 Engine exhaust
- 11 Bilges pumps discharges
- 12 Anti-syphon engine water breaker
- 13 Aft water tank vent
- 14 Fuel tank vent
- 15 Propane gas peak discharge

Toilets

The following recommendations do not replace the information provided by the Manufacturer in the Owner's Manual.

Instruction for the use of the marine toilets

- After checking that the sea cocks of the toilet in use are open, place the lever on top of the pump assembly to the position "fill basin".
- Flush the toilet by applying at least 20 strokes of the hand pump as discharge hose is nearly 4 mt. long!
- Place the lever on the "flush basin" position and continue pumping until the bowl is empty.

Cautions

- The toilet's water inlet and discharge circuits are equipped with siphon whose top is placed above the water line to avoid dangerous siphoning of water inside the vessel through the toilet.
- We recommend you close all toilet valves before sailing.
- This should also be done when you leave the yacht for long periods at the dock or during the off season.
 - When the yacht is laid up for long periods of time, flush the toilets with fresh water, flush dry and add some Vaseline oil to lubricate and preserve the toilet's interior and pipes.
- Never flush through the toilets sanitary diapers, matches, cigarettes, paper towels or non hygienic paper products because they will inevitably clog the toilets.
- Never use corrosive cleansers to clean the toilet's bowl. Only use special lubricating and reconditioning detergents and flush them thoroughly out.
- When taking apart a toilet for maintenance and repairs, always close the intake and discharge sea cocks.

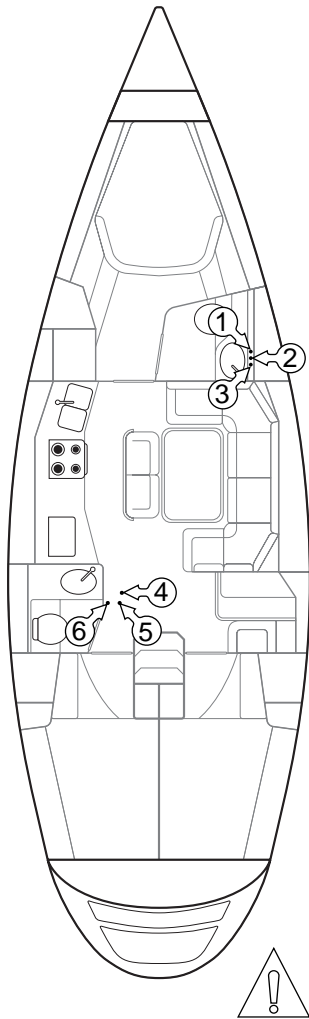

- 1 Intake forward toilet
- 2 Discharge fwd sink
- 3 Discharge fwd toilet
- 4 Intake aft toilet
- 5 Discharge aft sink
- 6 Discharge aft toilet



Refer to the owner's manual supplied by the Manufacturer for maintenance and operating instructions.

Tools to carry on board

Cantiere del Pardo does not provide the GS 43' with a tool kit apart from what comes with the main engine by the manufacturer.

The following is a list of the tools we recommend you carry on board:

- screwdrivers set
- hammers
- mallet
- portable, rechargeable electric drill & drill bits
- vice grips, pliers and channel locks
- set of open end spanners
- set of socket wrenches
- set of pipe wrenches
- set of Allan wrenches
- two adjustable spanners of different sizes
- files
- wire cutters
- awl
- hack saws and blades
- knives
- gauge
- wood and iron chisels
- rasp
- measuring tapes
- lubricants and anti seize oils
- electric tester
- battery tester

Waste water drainage from shower and sinks

Shower waste water drainage installation

- ◇ The shower water-collecting basins, located below toilet grating, are drained out by the electric bilge pumps fitted with filter on the intake.
- ◇ The control switch to the pump is the **BILGE PUMPS** which is located in the **PUMPS** section of the 12 V_{DC} Functions Panel (§ pages 7.5 & 7.6) whereas actual switches are in the front side of the sinks in the heads.
- ◇ The two electric pumps for draining the showers are located as follows (§ page 27.6):
 - **For the fore head**
under the central seat of the saloon, next to the fresh water pump.
 - **For the aft head**
in the front part of the engine compartment.
- ! • While showering or after, always drain water out of the basin by activating electrical pump.
- Drainage of the pumps flows into drainage collector located in aft port peak (§ page 27.1).

Waste water drainage operations are as follows:



- ◇ Before entering the shower, select the shower bilge aspiration valves as follows:
 - For the shower in the fore head, on the collector **C** under the central seat of the salon open the valve (c4) and close the other two (c2 and c3).
 - For the shower in the aft head, on collector **D** in the left front part of the engine compartment open valve (D2) and close the other one (D3).
 - Turn on the **BILGE PUMPS** switch which controls the electrical pump. It is located in 12 V_{dc} Functions Panel. This switch activates the local switches located in the toilets.
 - With the panel switch on, turn on the local switch for all the duration of the shower until waste water has been completely drained out.

+



- When finished, remember to turn off the main switch “BILGE PUMP” located in the 12 VDC Functions Panel (§ page 7.6)



Maintenance

- Check conducts condition every season.
- Regularly check and clean the filters on the shower drainage pump intakes and before the bilge pump.

Sinks drainage

+

- **Fore head washbasin**
 - The drainage cock is the central one of the three located inside the closet underneath the sink.
- **Galley sink**
 - The drainage cock is located below the sink itself.
- **Aft head washbasin**
 - The drainage cock is located under the floor board of the saloon in front of the head door and is the aft most toward the center.

Warning notices



Shut off washbasin and sink drainage cocks before sailing off.

+

+

Water Heater

The following recommendations should not replace the instructions provided by the manufacturer on the Owner's Manual.

- ◇ The Water heater of 18 lt. capacity is mounted under the sit of the chart table.
- The heater is built in stainless steel, very well insulated and equipped with a safety high pressure valve.



Instructions

To activate the water heater proceed as follows:

- Make sure that the gate valves installed on the top side of the main engine at the forward end are open. This is the circuit that will use the cooling water of the main engine to heat up the boiler's sanitary water. The valves can always be left on the open position and are provided as a safety feature in case of a leak of the system.
- Make sure that the valve (A1) of the outgoing water located on the A manifold of the cold water as well as the valve (b1) of the incoming water on the B manifold of the hot water are open (§ page 27.6 & 27.7).
- Activate the **FRESH WATER PUMP** switch on the 12 Vdc electrical panel (§ 7.6) and check that the pressure builds up in the hot water circuit.
- To heat up the water you can use the cooling water from the main engine which transmits the heat to the fresh water through a coil inside the heater or through the electrical heating element inside the boiler. This is powered with 220 Volts AC.
- In the first case the heater will provide hot water automatically each time the engine is functioning. You can expect water between 50° and 60° Centigrade after running the main engine at 1500 revs for fifteen minutes.
- To activate the electrical heating element inside the boiler hook up the shore power and then switch the **BOILER** breaker on the 220 Volt panel. (§ 7.9).

CHART TABLE SEAT

Water heater location

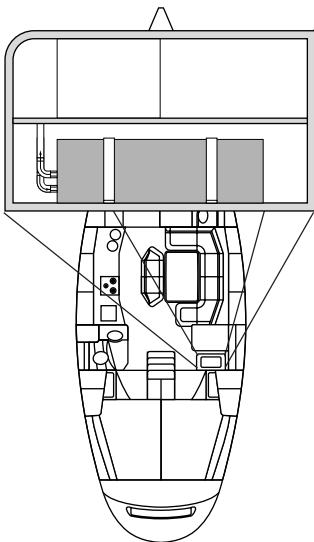

Maintenance and precautions



The Water Heater contains hot water under pressure; therefore we recommend:

- Always verify that the ventilation grid on the fwd side of the seat is not obstructed.



- Periodically verify the state of the pressure safety valve installed on top of the heater:



- if you notice leaks of water or steam, immediately interrupt the water/heater main engine water circuit using the two above mentioned gate valves and the 220 volt circuit breaker.

- Check for leaks on all pipes and hoses.
- Change the safety valve according to the manufacturer's maintenance program.
- During winter lay up, empty all water from the inside of the boiler and the pipes to avoid ice formation and subsequent pipe blow-up.



- Periodically inspect the anti-corrosion anode (see manufacturer's manual) and replace if corrosion exceeds 25%



Always consult the Water Heater Owner's Manual for instructions and maintenance.

Water system

For the location of the components of the water systems described in this chapter, consult the diagrams on pages 27.6 and 27.7

The water system on the Grand Soleil 43' is divided into the following sub systems:

- ◇ **Pressurized hot and cold fresh water**
- ◇ **Manual (opt) driven fresh water**
- ◇ **Sea water** (foot pump, Opt.)

Tanks

- ◇ The fresh water tanks fill caps are on deck (see diagrams):
 - one (1) is in the bow inside the anchor peak on the starboard side of the windlass and fills up directly the fore water tank (2);
 - one (4) is in the cockpit where the helmsman stands on the starboard side (opposite to the fuel tank fill cap) and fills up the aft water tank (5).

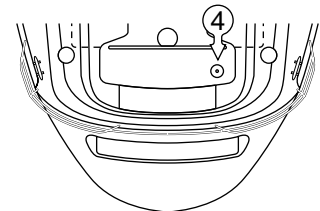
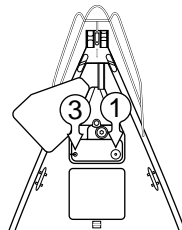
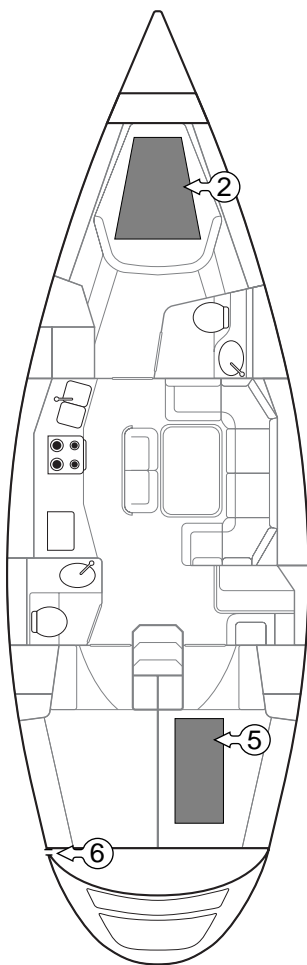

- ◇ The GS 43' has two fresh water tanks placed as follows:
 - One under the double berth of the fore cabin with a capacity of 200 lt.
 - One under the double berth of the stbd. aft cabin with a capacity of 200 lt

The tanks are made of a special alimentary fiberglass, are equipped with inspection ports and have a total capacity of 400 litres.

- The vent of the fore tank is opposite to its fill cap in the anchor peak.
- The vent of the aft tank is in the aft topside of the hull on the port side.
- ◇ The level of the water of the aft tank only is indicated by the gauge next to the chart table under the 12 Vdc. Electric Panel and is activated automatically when the switch of **FRESH WATER PUMP** is on.

Legend

- 1 Fill cap fwd water tank
- 2 Fwd water tank
- 3 Fwd tank vent
- 4 Fill cap aft water tank
- 5 Aft water tank
- 6 Aft tank vent

+

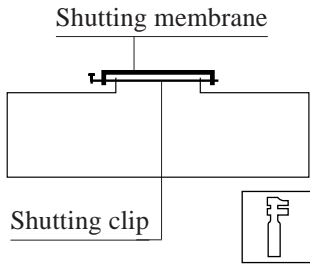

Tank inspection

- ◇ The inspection ports, one for each tank, are placed on the top of the tanks and they are made of a rubber gasket held firmly in place by a hose clamp.
- ◇ Although the tanks are built following the highest hygiene standards, they should be thoroughly cleaned and disinfected at least once a year.



Filling instructions

- While filling the tanks:
 - avoid excessive water pressure.
 - we suggest to leave always close the two valves of the selector **E** between the tanks.

+

Pressure water system

- ◇ **Fresh water** reaches the tanks directly from the water intake on deck or from the water maker (Opt).
- From the fore and aft water tanks, the water goes to the valves placed on the selector **E** (§ page 27.6) located under the central seat of the salon.
- Then water goes through the filter **F**, to the water pump **G** and from there to the water gun barrel **H** (§ page 27.6).
- From here the water is fed through the cold water manifold **A** (§ page 27.7) to the four cold water outlets on the yacht (shower and sink in the fore head and the aft head, galley sink and on deck shower) and to the water heater.
- **Hot water** from the heater § page 26.1) reaches the hot water manifold **B** located under the floor boards of the salon and from there goes to the four hot water outlets on the yacht listed above (§ pages 27.6 and 27.7).
- ◇ A foot pump (opt) to provide water to the galley sink may be connected directly to an extra valve placed on the cold water line between the filter and the water pump (§ page 27.6).

+

+



Instructions



Always consult the Water Pressure Pump Owner's Manual for instructions and maintenance.



- It is extremely important that a minimum amount of water must be at all times in the tanks to avoid that the fresh water pressure pump should lose its prime by sucking air. This would cause the pump not to shut off and to burn out.



- Should the water pump run continuously with all faucets closed, we recommend that you switch off the pump at the electrical panel (§ 7.6) and refill the tanks

- If you are about to run out of water, we recommend to keep the water pump off while motoring as the noise of the engine can cover the noise of the pump running with the risk of burning it. Same thing applies to the night time and when the boat is left unattended.

- When using fresh water, make sure that one of the two gate valves of the selector E is always open while the other one is shut off.

- We recommend to use the fore tank first as its level of water is not indicated by the gauge and, most important, is the one that affects more the pitching of the boat.

- Activate the switch marked **FRESH WATER PUMP** on the Pump Section of the 12 Vdc Electrical Panel (§ 7.6).

- The hot water may be brought to temperature through two separate systems:

- Utilizing the Main Engine Cooling Water System through a Heat Exchanger that automatically heats up the fresh water every time the main engine is on (*it will take approximately 15 minutes to reach temperature*).

- Turning on the Water Heater Switch (Boiler) on the 220 Volt AC section of the electrical panel (§ 7.9).

- Carefully read Chapter Water Heater on page 26.1

Foot pump fresh water system (opt)

◇ Galley:

- Push repeatedly the pump pedal (Opt) for fresh water to the sink. If the valve placed between the filter and the electric pump is open, the system is always primed.

Sea water system to galley sink (Opt)

- ◇ The system is fed through an extra seacock positioned under the galley sink.
- Sea water pumped out by mean of its own foot pump (Opt) will exit through its own faucet in the galley sink.

Cautions and general precautions



- No water should ever be in the bilges if all systems work properly. If you notice water in the bilges, find out if the water is fresh or salt:
 - in the first case check the fresh water distribution system and the gasket around the mast collar (it could be rain water!);
 - otherwise check the sea water system and all other possible leaks (engine, heads, etc.).
- Before switching on the water pressure pump, we recommend that you check the fresh water level in the tanks and that the correct valve (E) of the circuit is open.



- The water pump could be damaged if it should run too long without a water supply. In this case shut off the switch and refill tanks.
- Before turning on the water heater, read the manufacturer manual and Water Heater chapter at page 26.1
- In case of localized leaks or of periodical maintenance, shut down the pertinent sectors of the system or the main shut off switch.



- Before the winter season, tanks should be emptied and the system should be drained of water to avoid serious damage. Water in the pipes or manifolds could freeze and break pipes.
- The same should be done to the water heater and heat exchanger.
- We suggest not to use sea water (Opt) in heavily polluted areas.



- Remember that the whole sea water system (Opt) is located under water. If a leak appears in this circuit shut off the entire system by closing its seacock (see diagram page 22.1)



Maintenance

- Check frequently the fresh water filter **F** positioned before the pump.
 - Check periodically for leaks through the whole length of the system paying special attention to the condition of the gaskets, the connections and the fittings.
 - Generally speaking a clear symptom of a leak is an intermittent start of the water pump when all the faucets are shut off.
 - In this case you should proceed to a localized inspection, open one sector of the system at a time to spot out the leak in an easier way.
 - Check periodically (especially when you haul out the boat) the state of the seacocks and gate valves, paying special attention to the state of their bronze components. If they should show wear and corrosion, change them immediately.
- +
- +
- +

Location of the principal components of the fresh water system

- A Cold water manifold
- B Hot water manifold
- C Fwd bilges selector
- D Aft bilge selector
- E Water tanks selector
- F Filter
- G Water pump
- H Water gun barrel
- I Water heater
- L Fwd bilges pump
- M Aft bilges pump
- N Foot pump (opt)

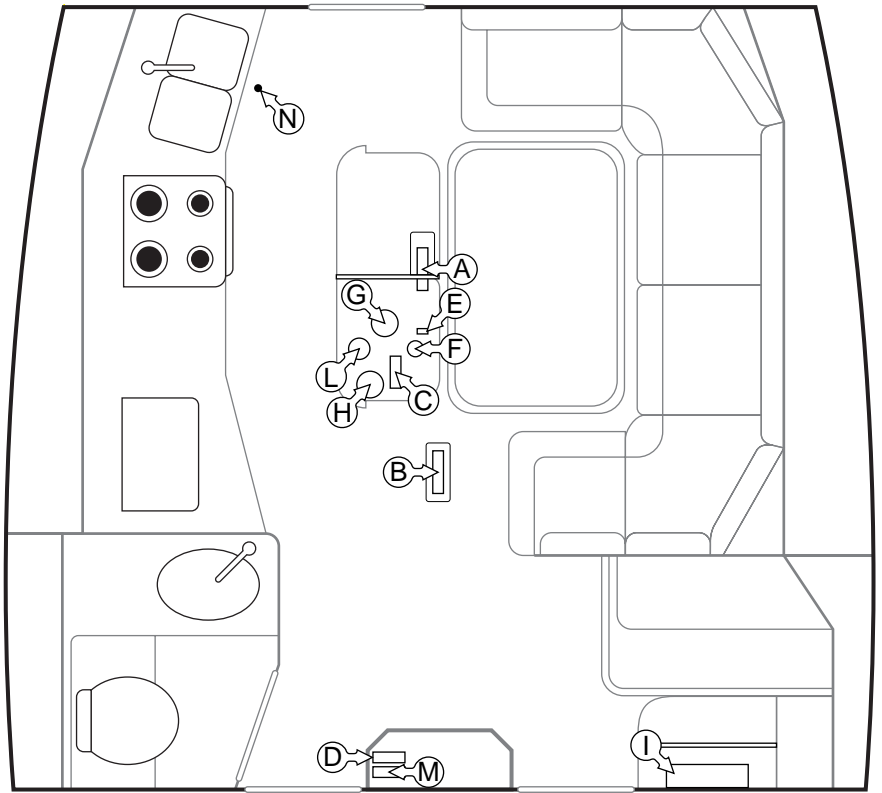

Water system flow chart

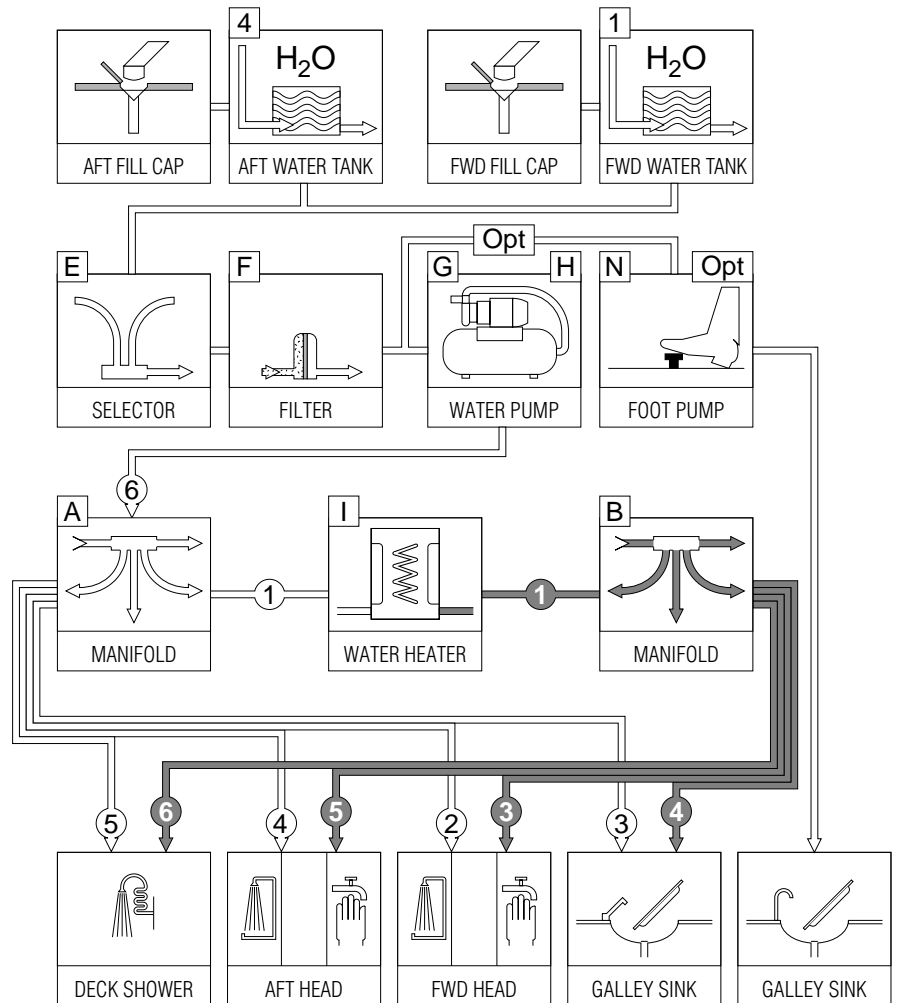

Note: number of the lines correspond to each manifold and selector exits (§ 27.7)

Fresh water manifold diagrams

Manifold		A	Cold water	Manifold		B	Hot water
▲	A1	Out	To water heater	▼	B1	In	From water heater
▲	A2	Out	To forward head	▲	B2	Out	Available
▲	A3	Out	To galley sink	▲	B3	Out	To forward head
▲	A4	Out	To aft head	▲	B4	Out	To galley sink
▲	A5	Out	To deck shower	▲	B5	Out	To aft head
▼	A6	In	From water gun barrel	▲	B6	Out	To deck shower

Bilges selectors diagrams

Selector		C	Fwd bilges	Selector		D	Aft bilges
▲	c1	Out	To the pump	D1	▲	Out	To the pump
▼	c2	In	From the sails' peak bilge	D2	▼	In	From the aft head shower bilge
▼	c3	In	From the mast step bilge	D3	▼	In	From the saloon main bilge
▼	c4	In	From the fore head shower bilge	D4	▼	In	Available

Winches

The Diagram on page 11.2 illustrates the functions of each winch.



Caution

Winches require relatively little maintenance but, being built out of components of different metals like steel, aluminium and bronze, they are subject to galvanic corrosion in the presence of salt and moisture. This is particularly true where stainless steel bolts are in direct contact with aluminium plates in the presence of salt crystals. Winch components are also covered with a light protective oil or grease film that, through use and lack of maintenance, can become polluted with impurities and salt crystals. This will not only reduce lubrication, but actually can cause the blocking of the winch and damage its internal components.

- Regular maintenance will eliminate these problems.
- Follow the manufacturers instructions and maintenance schedule.



Maintenance

- Wash periodically with fresh water, especially after sailing in rough weather.
- Clean and lubricate once a month the main bearings
- The inner bearings and gears should be checked and lubricated by a qualified technician at least once during the season.



Refer to the Owner's manual supplied by the Manufacturer.

Wintering

Batteries

The “life” of the batteries depends basically by the way they are used: the best thing would be to keep them always “working” by discharging and then recharging them frequently.

- If the boat is stored on a dry-dock, the best thing to do will be to take them to a car electrical shop that will do the periodical maintenance.
- Same thing must be done if the boat stays afloat: unless solar panels or a wind generator are installed, somebody must periodically start the engine or the battery charger and turn on some electrical component.
- In both cases the battery terminals should be coated with Vaseline.

Bilge

Is one of the most important part:

- first of all dry completely out the sea water;
- then wash possibly with a specific detergent that will dissolve also the grease;
- rinse, empty and let completely dry;
- leave the floor boards open for ventilation.

Bilge pumps

- If the boat stays afloat, they must always be in perfect conditions. Therefore:
 - clean and grease or spray the outside to prevent corrosion;
 - let them run periodically with fresh water (preferably hot) to dissolve the salt crystals;
 - check and grease the impellers;
 - in case of membrane, suck up an emulsion of warm water and Vaseline oil.
- If the boat is lifted out of the water:
 - same procedure as above but leave the impeller outside after greasing.

+

Canvas

Is the best protection against the sun and the rain and can allow you to keep some hatches ajar.

- A good solution could be to tighten a rope from the fore stay to the mast and from this to the back stay in a way to create a kind of “Canadian tent” that can be fastened to the deck to keep a good ventilation.

Deck fittings

Stainless fittings should be coated with a protective film, either with a marine spray or with Vaseline oil.

- In fact there is a form of corrosion, generally originated by the air pollution, that’s called “pitting corrosion” that produces little rust spots even on A.I.S.I. 316 stainless steel.
 - A light film of the above products can help to prevent corrosion and can be easily removed with gasoline or denatured alcohol.

+

Electronic instruments

Thieves can be one of the main problems: you can prevent them by taking away as many instruments as possible, making notes of the connections to facilitate the opposite operation in springtime.

- Otherwise leave them covered and protected as much as possible from rain and sun. Where possible, remove internal batteries.

Engine

+

The engine should run for an hour at least once a week: in this case no special wintering procedure is required except adding the anti-freeze liquid in the cooling system and the normal maintenance (oil checks and change, filters, etc.).

Otherwise if the engine cannot be started for long time, you should follow the wintering procedure given by the manufacturer that generally indicates the following operations:

- Change fuel filter.
- Start and warm up the engine and then change the oil and its filter.
- Close the seacock and clean the sea water strainer.
- Disconnect the cooling water pipe and put it into a bucket that you will keep full of fresh water.

+

- Start the engine and let it run for almost an hour with fresh water that will wash away the salt from the system.
- Add extra anti freezer liquid in the bucket and stop the engine allowing the liquid to remain in the cooling system.
- Take down the impeller of the water pump: clean it, coat it with Vaseline and then replace it.
- Slacken the alternator transmission belt and any other belt connected to the engine (frigoboat, water-maker, etc.).
- Before starting the engine in spring time, is better to dismount the injectors and take them to a specialized shop to get calibrated.

Fire extinguishers

If they are still working and in good conditions is better to leave them on board: they may be used in case of fire. If expired, recharge them and then replace.

Fuel tank

If during the last season you have had troubles with the fuel line (pipe, injection pump, injectors, etc.), is advisable to empty completely the tank and clean it thoroughly through the inspection porthole.

Add anti-freeze preservatives and leave the tank full of fuel to prevent the condensation of moist and oxidation of the fuel line.

Hatches

Before closing them permanently, is better to grease the rubber gaskets with Vaseline or silicone grease.

Is also advisable to shade the light that, shining through them, can damage the varnish of the wood frame and the furniture.

Hull bottom

After hauling the boat is necessary to clean the bottom of the hull from sea shells, barnacles and weeds.

The anodes should be taken out before they get oxidated and stuck to the bolts.

- The ground plates, the sea cocks and the propeller can be cleaned with an iron brush.

+

Hull topsides

Both leaving the boat afloat or aground, to preserve the brightness of the gel coat is advisable to apply on the topsides some polish. Among the different marine types available, for a long winter stop especially in industrial areas, rather than a cleaner is preferable to use a silicon based product that can protect better against air pollution.

- If the topsides are not white, remember that the darker the colour, the more they tend to lose the brightness in the long run.
 - in this case it is advisable to protect the gel coat from the ultraviolet rays with a tarpaulin skirt.

+

Interiors

First thing to be done is a deep clean up with a vacuum cleaner and then detergent to remove the dust and specially the salt crystals (that are the worst enemies as they absorb humidity and consequently creates mould and oxidation). All the foodstuff (including cans) should be taken away.

Very efficient are the hygroscopic salts dehumidifiers that are cheaply available in any hardware store and can be placed in any locker and also in the engine compartment.

The mattresses should be taken away as the foam absorbs humidity. Also linen, curtains, clothes and other fabrics should be taken away and washed.

+

To improve ventilation as much as possible, leave doors, cabinets and lockers open and blocked as well as the refrigerator that must be previously washed with a solution of water and vinegar.

Propane gas

Do not leave gas bottles on board.

- Take away the safety valve too: it can get corroded and stuck.

Running rigging, sheets and ropes.

The halyards and the reefs should be taken down and replaced with messengers.

- Then should be washed with fresh water without soap or detergents along with all the other cordage. Finally store them only when completely dry.

+

Sails

Take them all away, including the furling main sail.

- Wash them with fresh water (the dinghy can be used as water basin) and then hoist them upside-down on the mast to let them dry gently in a day of little wind.
- When completely dry, fold them and store in a dry place.

Seacocks and hose clamps

They all should be left closed and, if the boat stays in the water, they should be carefully checked one by one for leaks or cracks and then sprayed with W.D. 40 or silicone grease. If the boat is hauled out of the water try to plug the external holes too as they can easily become a wasps' (or other insects) nest.

Waterworks

It is the system that's most affected by the cold temperatures. The water should be completely drained not only from the tanks but also from:

- the pipes;
- the water pump;
- the water heater.

If the water is not drained out it can freeze and crack the pipes or get rotten. It is advisable to clean thoroughly the tanks with diluted chlorine through the inspection cap.

W.C.

Before the winter stop it should be flushed abundantly with fresh water and neutral detergent. To do that properly, do as follows:

- Close the intake seacock, release the hose clamp and put the aspiration pipe in a bucket full of water and soap;
- flush it all out;
- rinse it all out;
- fill the bucket with a mixture of water and 1/2 litre of Vaseline oil and flush it;
- When nearly empty close outlet seacock allowing the oil to stay into the pump.

In this way the rubber membrane remains soft and clean, working perfectly for years.

Tips for a safe winter mooring

- Add an extra couple of dock-lines in the stern and put strong springs for the tide. Do not use winches as “permanent mooring cleats” as in the long run the internal shaft can get damaged.
- Cover the ropes with a rubber pipe or strong leather where they pass through bits, to prevent chafing damages.
- Double up the front lines making sure that they are tighten equally and not crisscrossed.
- Leave an abundant slack on the dock line bearing in mind the local tidal excursion.
- Place at least four fenders on each side, better if hanged in horizontal position in a way to cover a larger area and to have a double binding.
 - Do not fasten them on the railings but at the stanchions base or on other sturdy place.
- For the sake of the topsides is recommendable to cover the fenders with a strong fabric also available in any ship chandler.
- If provided, lift high up the gangway well clear from the dock.
- Unplug the shore power.
- Leave the keys to the boat and your telephone number to the guard of the Marina remembering that a good tip is always welcome! If a guard is not available, try to reach an agreement with your neighbour to help each other to keep an eye on the boat and possibly to open it periodically for ventilation.

Yacht's trim

The distribution of the weights and the masses on the Grand Soleil 43' is the result of very accurate tests and studies by the J & J Design and Cantiere del Pardo.

In normal load condition, the Grand Soleil 43' floats and sails perfectly on its ideal lines.

However, as with any other yacht, failure to comply with the basic rules for the distribution of the loads may cause the yacht to get out of the ideal trim. This might cause a bow or stern trim or even a list to port or starboard.

These variations will not cause serious problems but may compromise the sailing performances of the yacht and its cruising comfort. Loading should therefore be carried out according to the following principles:

- limit the loads only to the gear and items which are strictly necessary on board;
- distribute the weights evenly throughout the yacht trying to concentrate the heaviest items amidships and as low as possible;
- do not overload the yacht's ends, the bow especially since this problem is the one that most of all affects the yacht performances. For this reason we recommend to use the fwd. water tank first and then the aft. one to keep the bow as light as possible. In case of beating up against rough sea, better keep the fwd tank empty anyhow.
- distribute the masses as evenly as possible on the lateral plane too; however do not worry if the boat has a slight list once loading has been completed: a slight list is acceptable and far less influent than the fore and aft trim on the yacht's performances.
- ensure that all masses are securely fastened or lashed and will not shift during navigation.