

OCEANIS 46.1

OWNER'S MANUAL



BENETEAU



197837 RCD-2
Index C



CONTENTS

5	Introduction	
9	Technical specifications	1
13	Design categories and displacement	2
17	Stability and buoyancy	3
25	Manoeuvrability	4
29	Rigging and sails	5
45	Safety	6
63	Information relating to fire risks and risks of explosion	7
73	Electrical system	8
119	Liquefied Petroleum Gas system (LPG)	9
125	Domestic appliances	10
133	Audio-visual equipment	11
137	Onboard comfort	12
157	Water systems	13
203	Engine	14
215	Steering system	15
223	Deck fittings	16
235	Hull fittings	17
241	Handling, transport	18
249	Environment	19
251	Appendix	

INTRODUCTION

Welcome!

You have just been delivered your new BENETEAU boat and we thank you for the confidence you have shown in us by ordering from our brand. The whole BENETEAU team welcomes you on board.

A BENETEAU is made to last and to bring you all the pleasure you should expect from a boat over a period of many years. Each boat is subject to the utmost attention to detail from the design stage right through to launching.

This manual is designed to help you to enjoy your boat comfortably and safely. It includes the boat's specifications, the equipment provided or installed, information on the boat's systems and some tips on operation and maintenance. Some of the equipment described in this manual may be optional.

Your BENETEAU dealer will be able to help and advise you on the use and maintenance of your boat. The first time you use your boat a high level of skill and attention will be required. The proper functioning of all equipment will depend on the initial set-up being carried out correctly. For this reason the first launch must be carried out under your dealer's supervision.

Read this Owner's Manual carefully and take time to get to know your boat before you use it.

The better you know your vessel, the better your experience will be when sailing it.



For each piece of equipment on your boat, please read the instruction manuals provided by the manufacturer.

Keep this manual somewhere safe and pass it on to the new owner should you sell your boat.
You are advised to keep any user's guides supplied by the manufacturers of any equipment for your boat (accessories, etc.), together with your manual.

■ This manual is written to help you enjoy your boat in safety. It contains details of the boat and of all the equipment provided and installed on your boat, as well as instructions for its use. Read it carefully and get to know your boat properly before using it.

■ This owner's manual is not in any way a navigation or mariner's training manual. If this is your first boat or if you have changed to a type of boat with which you are not familiar, make sure that you learn how to use it and manoeuvre safely and with ease before taking the helm alone. Your dealer, national sailing or motorboat association, or yacht club will be very happy to tell you about navigation schools or qualified instructors in your area.

■ Make sure that the wind and sea conditions forecast are appropriate for the design category of your boat and that you and your crew are capable of manoeuvring the boat in these conditions.

■ Even with a well-adapted boat, the wind and sea conditions which correspond to the design categories A,B and C range from storm force winds for category A to severe storm conditions at the upper end of category C, and could put the boat at risk from very large waves and strong gusts. These are dangerous conditions in which only an experienced, fit and well-trained crew, manoeuvring a well-maintained boat, will be able to navigate with sufficient skill.

■ This owner's manual is not intended as a detailed maintenance or repairs manual. Should any problems arise please contact your dealer. If a maintenance manual is provided, please use it.

■ Always use the services of an experienced professional for the maintenance of your boat, for fitting accessories and for any modifications. Any alterations which may affect the safety specifications of the boat must be assessed, carried out and recorded by persons qualified to do so. The boat manufacturer cannot be held responsible for any modifications not approved by them.

■ Some countries require you to hold a Certificate of Competency or other such qualifications, or there may be other specific regulations in force.

■ Always maintain your boat well and make note of any deterioration due to wear and tear or to heavy or inappropriate use.

■ Any boat – no matter how well-built – could suffer serious damage if used recklessly. This kind of use is highly unsafe. Always adjust the speed and heading of your boat according to the sea conditions.

■ If your boat is equipped with a life-raft, read the instruction manual carefully. The crew must have all safety gear available onboard (lifejackets, harnesses etc.), and this must appropriate for the type of boat and for the weather conditions. In some countries it is mandatory to have this safety equipment onboard. The crew must be fully familiarised with the use of the safety gear and with emergency manoeuvres (man overboard procedures, towing another vessel etc). Sailing schools and clubs regularly run training sessions for these skills.

■ It is strongly advised that everyone wears an appropriate flotation device (lifejacket or personal buoyancy aid) when on deck. Be advised that in some countries it is mandatory to wear a flotation device which meets the national regulations at all times.

Notes on reading this manual

The various symbols used throughout the manual for crucial safety information are as follows:



DANGER

Indicates a serious inherent danger with a high risk of death or serious injury if the appropriate precautions are not taken.



WARNING

Indicates a danger which could lead to injury or death if the appropriate precautions are not taken.



WARNING

Either indicates a reminder of safety procedures or alerts you to dangerous manoeuvres or operations, which could result in injuries to those onboard, damage to the boat and its components or damage to the environment.



ADVICE-RECOMMENDATION

Indicates recommendations or advice for carrying out the correct manoeuvres for the planned course of action.

- While some of the information and illustrations in this manual may show details which are slightly different from those found on your boat, the key information remains the same. Future versions of this manual will show any possible modifications as required.
- Due to the constant desire to improve the products, SPBI S.A. reserves the right to make any changes considered necessary to the design or to the equipment. The specifications and information given are not contractual and may be modified without prior notice or updates.



- This owner's manual is written in several languages. French is the authentic reference language.
- This owner's manual was written and formatted by SPBI S.A.. Any reproduction of this manual, direct or indirect, provisional or permanent, by whatever means, whether in whole or in part, as well as any modification by third parties for commercial reasons, is forbidden.

TECHNICAL SPECIFICATIONS

■ Construction	10
■ General dimensions	10
■ Engine.....	10
■ Electricity	10
■ Capacities.....	11
■ Sails	12

1.1 CONSTRUCTION

Model.....	OCEANIS 46.1
Architect / Design	Pascal Conq / Nauta design
Builder	SPBI S.A
Principal means of propulsion	Sail
Deck construction material	Laminated sandwich glass / GRP / Foam
Hull construction material	Single skin laminated fibreglass / GRP
Deck implementation	Injection
Hull implementation	Wet laid fiber

1.2 GENERAL DIMENSIONS

L.O.A (L_{max})*	14,60m
<i>(Including removable parts that can be dismantled (bow roller, pulpit, bowsprit), without affecting the structure of the boat)</i>	
Hull length (L_h)*	13,65m
<i>(Excluding: removable parts that can be dismantled without affecting the structure of the boat)</i>	
Overall width (B_{max})*	4,50m
<i>(Including: removable parts that can be dismantled without affecting the structure of the boat)</i>	
Beam(B_h)*	4,50m
<i>(Excluding: removable parts that can be dismantled without affecting the structure of the boat)</i>	
Air draft - Empty vessel: Classical mast	20,31m
Mast Performance	21,31m
Draught - Boat fully laden: Deep draught keel version	2,47m
Shallow draught keel version	1,87m
Very deep draught keel version	2,68m
Wetted surface area	Approximately 52 m ²

1.3 ENGINE

Nominal maximum propulsion power (at the propeller output)	1 x 59Kw
Maximum recommended engine size	2 x 229kg

1.4 ELECTRICITY

Circuit type: Direct current DC	12V
Alternating current AC	220V
AC (US Version)	110V

1.5 CAPACITIES

Total mass of liquid contents of fixed tanks when full 1 130kg

NOTE: The density of a liquid can vary according to its temperature and quality.

The volume masses chosen are:

- 0,86kg/L for diesel fuel,
- 1kg/L for water.

Fuel capacity: (*)	195L
Auxiliary fuel tank (*)	200L
Fresh water capacity: (*)	330L
Extra water tank (*)	200L
Blackwater capacity: Fore WC	50L
Aft head	80L

It may not be possible to use these capacities fully depending on the trim and load of the boat. It is recommended that you keep a reserve of 20% in the fuel tanks.

(): Refer to the corresponding chapter to locate the position of the tank (each tank number corresponds to its position on board).*

1.6 SAILS

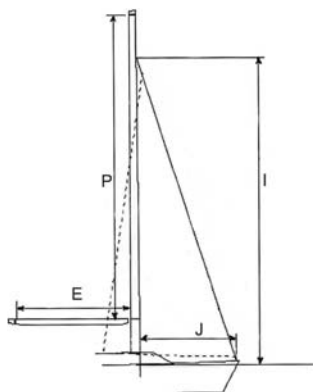

	Classical mast	Mast Performance
I: Distance between deck and highest genoa halyard sheave	17,72m	18,33m
J: Distance between the fore of the mast and the bow fitting on the deck	5,72m	5,71m
P: Length of the mainsail luff	16,82m	17,82m
E: Length of the mainsail foot	5,63m	5,63m

Classic mainsail.....	53,75m ²
Performance version mainsail	57,61m ²
Furling mainsail	44,46m ²
Furling genoa	52,16m ²
Furling genoa (Mast Performance).....	57,78m ²
Asymmetric spinnaker	151,70m ²
Self-tacking jib	40,42m ²
Code 0	101,84m ²
Planned sail area*	107m ²

* Definition: designated by (AS) and calculated as the sum of the projected surfaces in profile of all sails that can be established when the vessel is close hauling, on the booms, horns, bowsprits or other spars, and the surface of fore triangle(s) to the foremost forestay, fixed permanently during operation of the vessel with the mast bearing the established sails, without overlap, assuming that the jackstays and leeches are straight lines.

The surface of the spars is not included in the projected calculation sail plan area, with the exception of the wing-masts.

DESIGN CATEGORIES AND DISPLACEMENT

■ Shallow draught keel version.....	14
■ Deep draught keel version.....	14
■ Very deep draught keel version	14
■ Design categories.....	16

- Some information is shown on the manufacturer's plate fixed to the boat. Explanations of the information given can be found in the relevant chapters of this manual.

2.1 SHALLOW DRAUGHT KEEL VERSION

Design category	A	B	C	D
Maximum number of people onboard (CL)*	10	11	12	12
Light displacement (MLC)**	11 278kg			
Recommended maximum load (ML)***	4 200kg			
Displacement with maximum load (MLDC)****	15 478kg			

2.2 DEEP DRAUGHT KEEL VERSION

Design category	A	B	C	D
Maximum number of people onboard (CL)*	10	11	12	12
Light displacement (MLC)**	10 952kg			
Recommended maximum load (ML)***	4 200kg			
Displacement with maximum load (MLDC)****	15 152kg			

2.3 VERY DEEP DRAUGHT KEEL VERSION

Design category	A	B	C	D
Maximum number of people onboard (CL)*	10	11	12	12
Light displacement (MLC)**	10 789kg			
Recommended maximum load (ML)***	4 200kg			
Displacement with maximum load (MLDC)****	14 989kg			

NOTE: The options fitted onboard are included in the maximum load. The more options the boat has, the less room there is for provisions or personal belongings.

DEFINITION:

* **CL:** Crew Limit

** **MLC:** Mass of the boat in Light Craft Condition

includes the weight of the boat in the standard ready-to-navigate configuration, keel, standard equipment, engine(s) and sails (if the boat is a sailing boat).

*** **ML:** Maximum Load

- The recommended maximum load includes the weight of all people onboard, provisions, personal belongings, all equipment not included in the weight of the boat when not loaded, the cargo (if relevant) and all liquids contained in fixed tanks when full (fuel, water, greywater, blackwater).

- The maximum recommended weight shown on the manufacturer's plate does not include the weight contained in the fixed tanks of liquid when full (fuel, water, greywater, blackwater).

**** **MLDC:** Mass of the boat in Maximum Load Condition

Includes light ship mass (MLC) + maximum load (ML).

- If some of those onboard are children, the total number of people allowed onboard may be increased, provided that:
 - The total weight of the children does not exceed 37,5kg;and that
 - the total weight of all allowed onboard (based on about 75kg per adult) is not exceeded.

 - Do not exceed the recommended maximum number of people onboard. However many people are onboard, the total, combined load of people and any gear or equipment must never exceed the recommended maximum load.

- Always use the seats or seating areas provided.

 - When loading the boat, never exceed the recommended maximum load. Always load the boat with care and distribute weight evenly in order to maintain the optimum trim (more or less horizontal).

- Avoid placing heavy loads high up in the boat.

2.4 DESIGN CATEGORIES

Category A:

A yacht of design category A is considered to be designed for wind that may exceed force 8 (on the Beaufort scale) and waves that can exceed a significant height of 4 metres, but excluding exceptional conditions such as storms, severe storms, tornadoes and extreme sea conditions or very large waves.

Category B:

A yacht of design category B is considered to be designed for wind that may go up to force 8 inclusive and waves that can reach a significant height up to 4 metres inclusive.

Category C:

A yacht of design category C is considered to be designed for wind that may go up to force 6 inclusive and waves that can reach a significant height up to 2 metres inclusive.

Category D:

A yacht of design category D is considered to be designed for wind that may go up to force 4 inclusive and waves that can reach a significant height up to 0,3 metres inclusive, with occasional waves of a maximum height of 0,5 metres.

NOTE: Boats in each category must be designed and built to withstand these parameters in respect of stability, buoyancy and other relevant essential requirements, and to have good handling characteristics.

STABILITY AND BUOYANCY

- Stability information..... 18
- Access to the boat..... 20

3.1 STABILITY INFORMATION

- Fully laden displacement was used to evaluate the stability and buoyancy of the boat. The value of this displacement can be found in the "Technical specifications" paragraph at the beginning of this manual.
- Any changes in the distribution of loads onboard (for example by adding a raised structure for fishing, fitting a radar or in-mast furling, changing the engine etc.) can significantly affect the boat's stability, trim and performance;
- It is important to keep water in the bilges to a minimum;
- Adding weight high up on the boat will affect stability;
- In heavy weather it is important to close all the hatches, lockers and doors to minimise the risk of water pouring in;
- The boat's stability can be reduced when towing a boat or when using a davit or boom to lift a heavy load;
- Breaking waves are a serious threat to stability.



- Reduce speed in wavy conditions.
- Always adjust the speed and heading of your boat according to the sea conditions.
- All of the watertight hatches must remain closed when at sea.
- If the wind exceeds 20 knots, it is recommended that you stow all removable protection sheets (lazy bag, Bimini, awnings, ...).

- This boat was tested using the stability rating STIX, which is a worldwide safety measurement of stability and which takes account of the length of the vessel, its displacement, hull dimensions, stability characteristics and flooding proofness. This test produced the following results:

Shallow draught keel version

	Boat with minimal load	Boat with maximum load
Angle of vanishing stability (in degrees)	117°	109°
STIX	44	38

Deep draught keel version

	Boat with minimal load	Boat with maximum load
Angle of vanishing stability (in degrees)	118°	109°
STIX	44	38

Very deep draught keel version

	Boat with minimal load	Boat with maximum load
Angle of vanishing stability (in degrees)	118°	109°
STIX	44	38

- This boat is likely to capsize or be overrun if it is over-canvassed. In these circumstances, it may then sink. The sail plan should be adjusted according to wind and sea conditions and it is important to be particularly vigilant in case of gusty winds or squalls.



- The boat may capsize if carrying too much sail.
- It is important to take additional precautions in the event of strong winds, rough seas or breaking waves.

3.2 ACCESS TO THE BOAT

Access to the cockpit



NOTE: *It is essential that the guardrails remain closed when under way.*



- It is essential that both the cockpit and the engine compartment are kept closed when at sea.
- When at sea close the guardrail side-opening or openings.
- Slamming an access hatch may cause injury : always close the hatch gently and carefully.
- Do not allow children to open or close the hatches unsupervised.



- It is essential that companionway access is kept closed when at sea.
- Close the deck hatches and portholes before each trip.
- Close all access doors and hatches in heavy weather or when the sea is rough.



- When under way, keep hull valves and fillers in the closed position to minimise the risk of flooding.

Access to the engine compartment

Side hatch (Port and starboard aft cabins)



Companionway



Access to companionway



Holding





NOTE: Storage of the companionway doors: under the starboard cockpit seat.

MANOEUVRABILITY

■ Visibility from the steering station..... 26

4.1 VISIBILITY FROM THE STEERING STATION

The view of the helmsman from the steering station can be obstructed when under sail due to one or more variable conditions:

- 1) Load and load distribution;
- 2) Speed;
- 3) Sea conditions;
- 4) Rain and mist;
- 5) Darkness and fog;
- 6) Lights inside the boat;
- 7) Position of covers and curtains;
- 8) Persons or mobile equipment located in the helmsman's field of view.

Sails that may obstruct forward view:

- All except storm jib.

The international rules and regulations for avoiding collisions at sea (Col Reg / RIPAM) require a full and constant lookout as well as observance of the rules of right-of-way. Observance of these rules is essential.



- Manoeuvrability is reduced at excessive speeds.
- There is a risk of loss of control during tight turns.
- Reduce speed before making a turn in any direction.

4.1.1 Navigation lights

The navigation lights run on DC power.

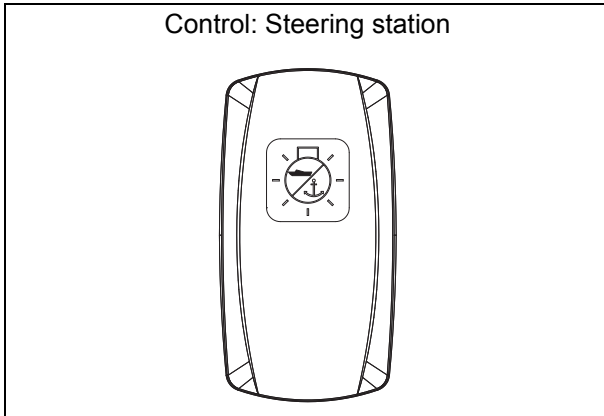
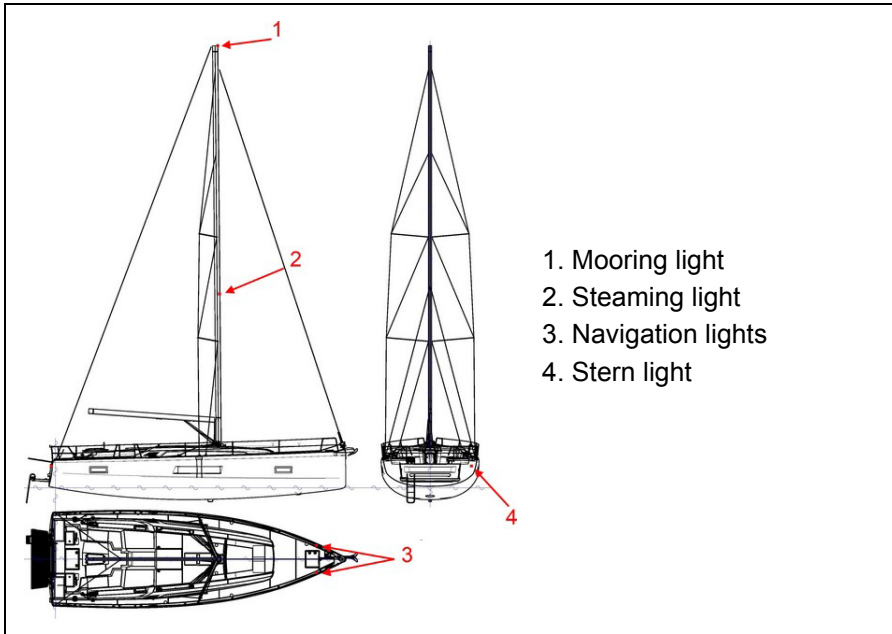

RIGGING AND SAILS

■ Rigging diagram	30
■ Standing rigging	31
■ Running rigging	34
■ Sails	35
■ Setting the sails	36
■ Deck fittings	41
■ Winches	42
■ Genoa furler	44
■ Single line furler	44

5.1 RIGGING DIAGRAM

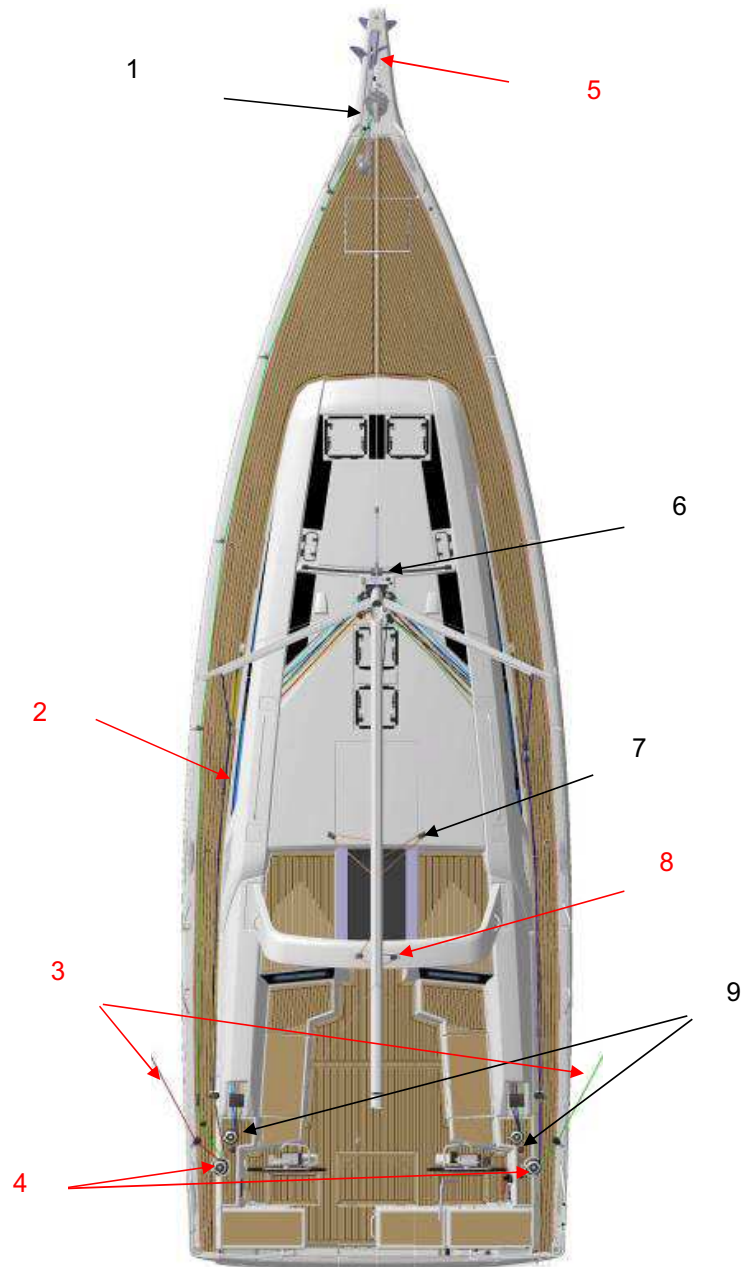

Reference	Designation
1	Genoa furler
2	Genoa traveller
3	Asymmetrical spinnaker sheet
4	Genoa winches
5	Asymmetric spinnaker tack
6	Self-tacking jib rail
7	Mainsheet on the roof
8	Mainsheet on the cradle
9	Coach roof winch

5.2 STANDING RIGGING

CLASSICAL MAST

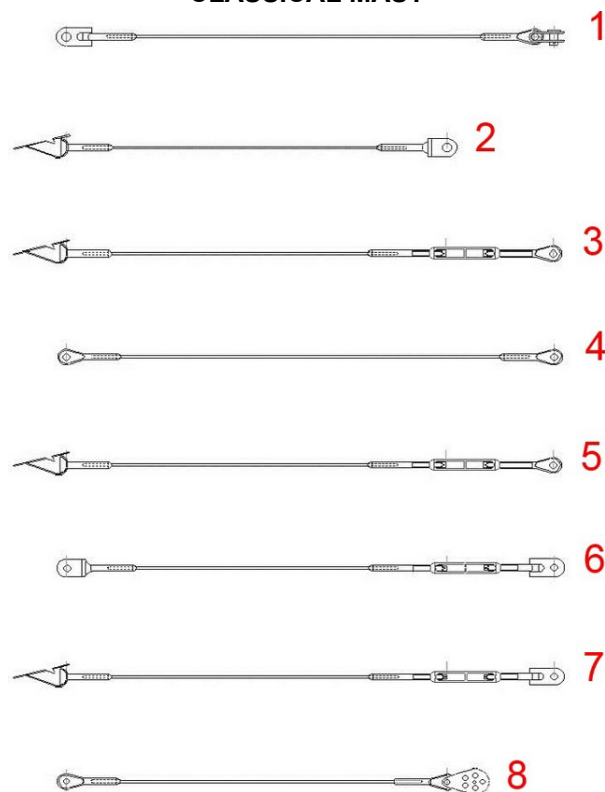

Reference	Designation	Quantity	Diameter (in mm)	material
1	Forestay	1	10	Cable
2	D3	2	8	Cable
3	D3'	2	5	Cable
4	V2	2	8	Cable
5	D2	2	7	Cable
6	V1	2	10	Cable
7	D1	2	10	Cable
8	Backstay	1	8	Cable



- To hoist a crew member up to the top of the mast, tie a bowline with the halyard directly onto ring of the bosun's chair (never use the halyard snap shackle or a carabiner).
- Hoisting a crew member to the masthead will reduce the boat's stability. The skipper is the sole person responsible for the decision to hoist a crew member up the mast. This decision will depend on sea and wind conditions..



- When the Genoa with furler is in position, the Genoa halyard must always be fully tightened. Regularly check the tension of the Genoa halyard when underway.
- When the Genoa sail with furler is removed (during winter lay-up or for maintenance, for example), it is important to keep the Genoa halyard away from the forestay which could cause the halyard to break and the boat to be demasted.



- The first time you use your boat a high level of skill and attention will be required. The proper functioning of all equipment will depend on the initial set-up being carried out correctly. The first mast stepping must be carried out under the supervision of the dealer for this reason.
- Before each trip, carefully inspect the mast from top to bottom.
- Periodically check the rigging tension and the tightness of the locknuts and turnbuckle clevis pins.

CLASSICAL MAST (SUITE)

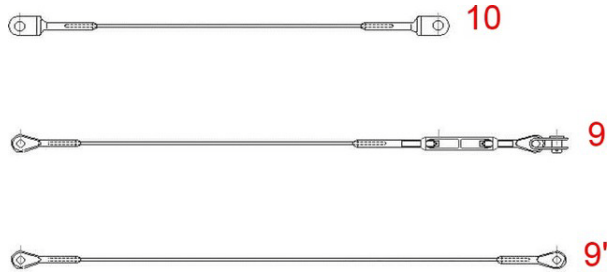

Reference	Designation	Quantity	Diameter (in mm)	material
9	Bridle (Port)	1	8	Cable
9'	Bridle (Starboard)	1	8	Cable
10	Backstay pendant	1	8	Cable

ICW MAST (INTERIOR COAST WAY)

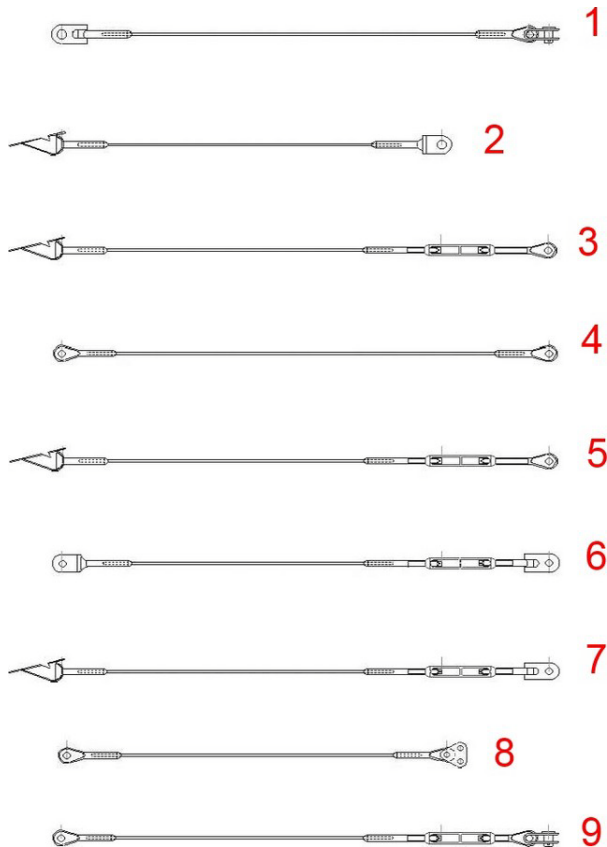

Reference	Designation	Quantity	Diameter (in mm)	material
1	Forestay	1	10	Cable
2	D3	2	8	Cable
3	D3'	2	5	Cable
4	V2	2	8	Cable
5	D2	2	7	Cable
6	V1	2	10	Cable
7	D1	2	10	Cable
8	Backstay	1	8	Cable
9	Bridle	2	7	Cable

MAST PERFORMANCE

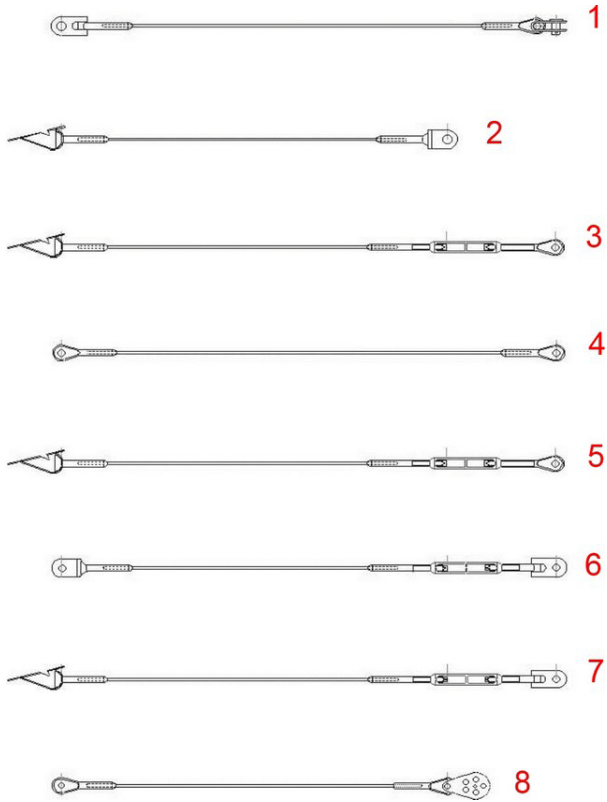

Reference	Designation	Quantity	Diameter (in mm)	material
1	Forestay	1	10	Dyneema
2	D3	2	8	Dyneema
3	D3'	2	5	Dyneema
4	V2	2	8	Dyneema
5	D2	2	7	Dyneema
6	V1	2	10	Dyneema
7	D1	2	10	Dyneema
8	Backstay	1	8	Dyneema

5.3 RUNNING RIGGING

- Check the general condition of the halyards and sheets and look out for any signs of wear.
- Regularly check the condition of the cams.
- Regularly clean the backstay blocks with fresh water.
- Avoid aggressive gybing in order to reduce premature wear on the sheets, attachment points and gooseneck.
- If halyard tension (mainsail/genoa) is too great, this can lead to problems when hoisting/furling.

SYSTEM AT MAST FOOT

Classic mast & Carbon mast

Starboard

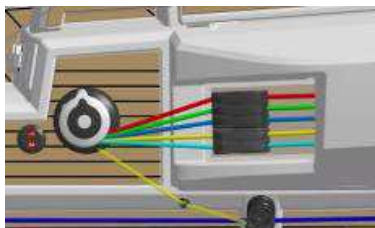
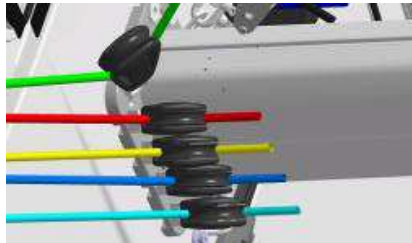
- 1
- 2
- 3
- 4
- 5

1. Kicking strap
2. Mainsail outhaul
3. Mainsail sheet (german sheeting)
4. Self-tacking jib sheet
5. Spinnaker halyard

Port



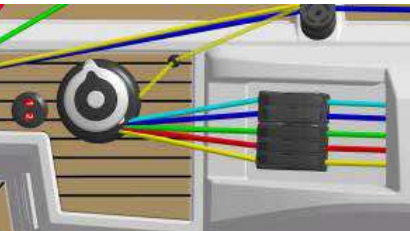
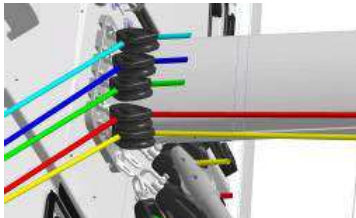

- 6
- 7
- 8
- 9
- 10

6. Genoa halyard
7. Main halyard
8. Reef 1
9. Reef 2
8. Mainsail sheet

Roller furling mast

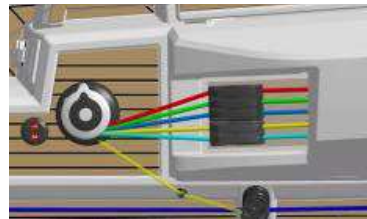

Starboard

- 1
- 2
- 3
- 4
- 5

1. Kicking strap
2. Mainsail outhaul
3. Mainsail sheet (german sheeting)
4. Self-tacking jib sheet
5. Spinnaker halyard

Port

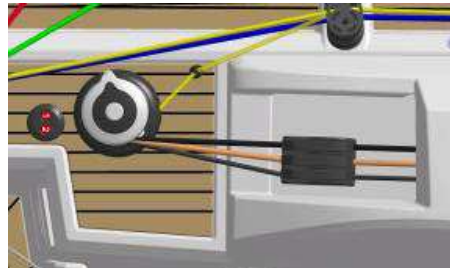
- 6
- 7
- 8

6. Main halyard
7. Mainsail safety block stopper
8. Mainsail sheet

5.4 SAILS

General points

- The working life of a sail depends above all on regular maintenance.
- When sailing, trim the sails to account for the stress placed on the fabric in order to reduce the chance of damage from strain.
- Secure your boat against wear and tear: Cover or protect gear with rough or sharp surfaces (spreaders, stanchions, etc.).
- Keep a sailmaker's kit and explanatory booklet onboard so that you can carry out emergency repairs whilst waiting for a professional sail-maker.
- Rinse the sails in fresh water regularly and dry them quickly to avoid mildew. Avoid drying the sails on the mast in the wind: Allowing them to flap freely wears the seams and increases the risk of tearing the sails on the rigging.
- UV rays are harmful for sails: If you are keeping your sails rigged, even for as short a period as 24 hours, cover them with a sail cover or protective fabric.
- The genoa can be fitted with an anti-UV strip: Make sure that the furling direction on the furling drum is correct (the UV strip must appear on the outside).
- Never use force if the sail sticks when furling or unfurling. If this happens, check that a halyard is not rolled around the forestay.
- The leech line must be released at the end of every sailing trip. If kept under constant tension, the leech line will cease to be adjustable after several trips..

Sail storage/folding

- Remove the sails if your boat is not to be used for a long time.
- Avoid storing sails wet to prevent mould and mildew.
- Fold the sail parallel to the foot into a concertina, then roll it up to fit into the bag.

Maintenance

- If an anti-UV strip is attached to the sail, it must be changed every 5 years or so..



When travelling at over 20 knots, you are advised to stow the lazy bag.



When the sailing season is over and, if possible, before Winter, take all the sails to a professional for servicing and for any necessary repairs.

5.5 SETTING THE SAILS

MAINSHEET SYSTEM (on mainsail arch)

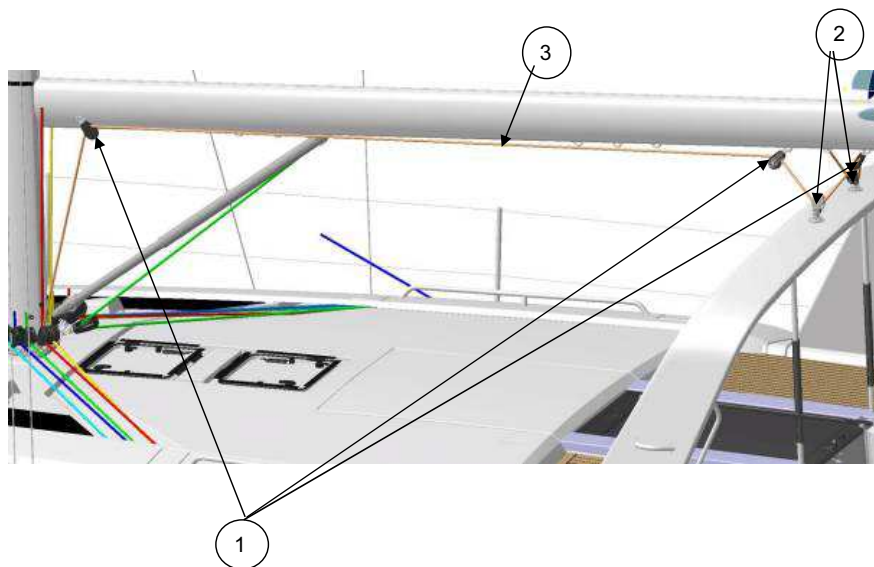

Reference	Designation
1	Single pulley
2	Single pulley
3	Mainsail sheet

German sheeting

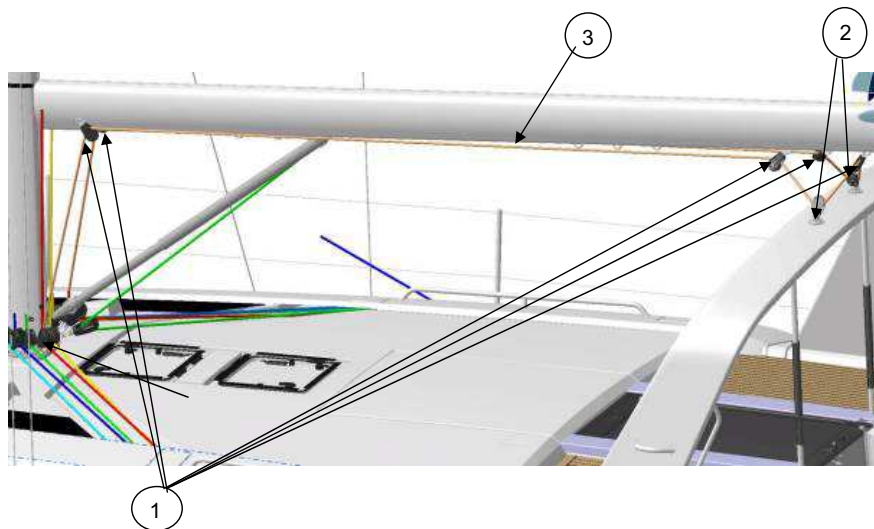

Reference	Designation
1	Single pulley
2	Single pulley
3	Mainsail sheet

FIRST LINE version

Reference	Designation
1	Harken single pulley (3215NP)
2	Harken single pulley (3227)
3	Mainsail sheet

MAINSHEET SYSTEM (on the coachroof)

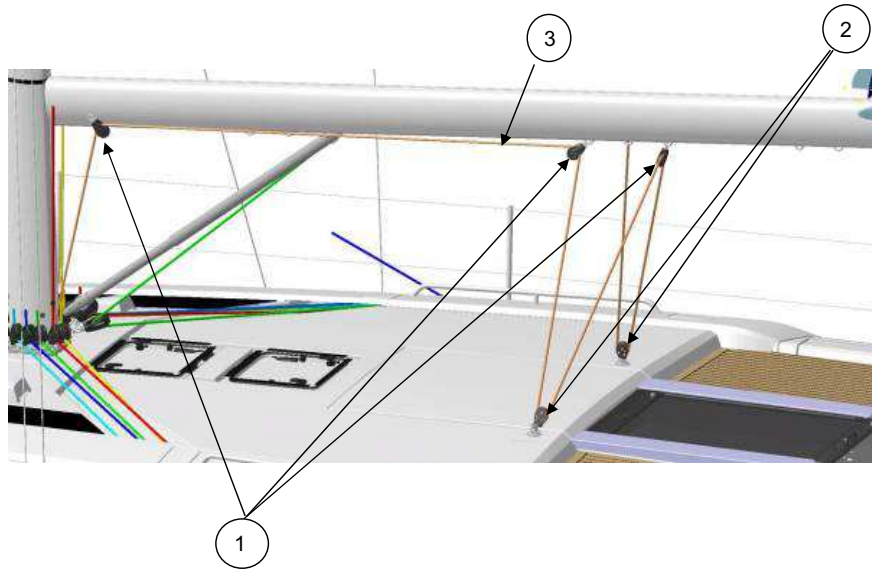

Reference	Designation
1	Single pulley
2	Single pulley
3	Mainsail sheet

German sheeting

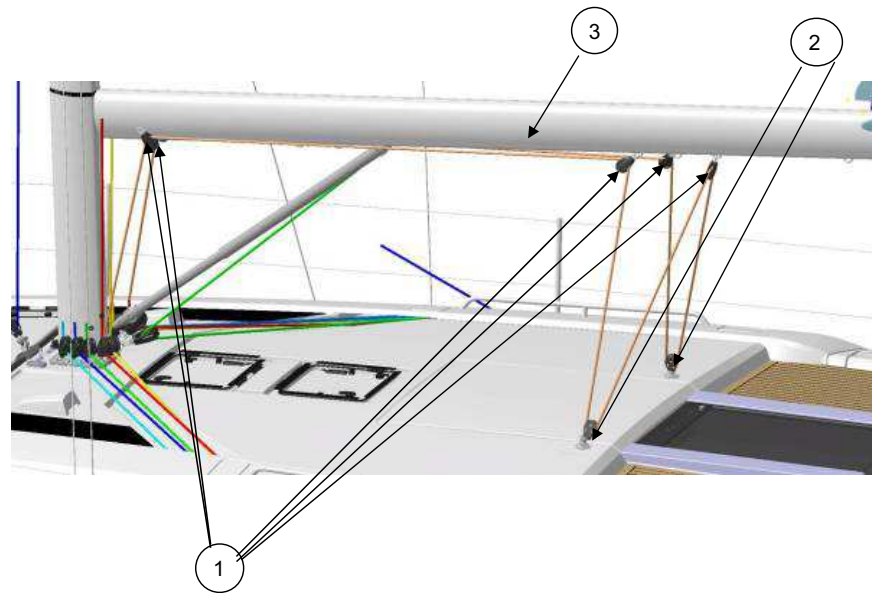

Reference	Designation
1	Single pulley
2	Single pulley
3	Mainsail sheet

FIRST LINE version

Reference	Designation
1	Harken single pulley (3215NP)
2	Harken single pulley (3227)
3	Mainsail sheet

GENOA CIRCUIT

Furling genoa

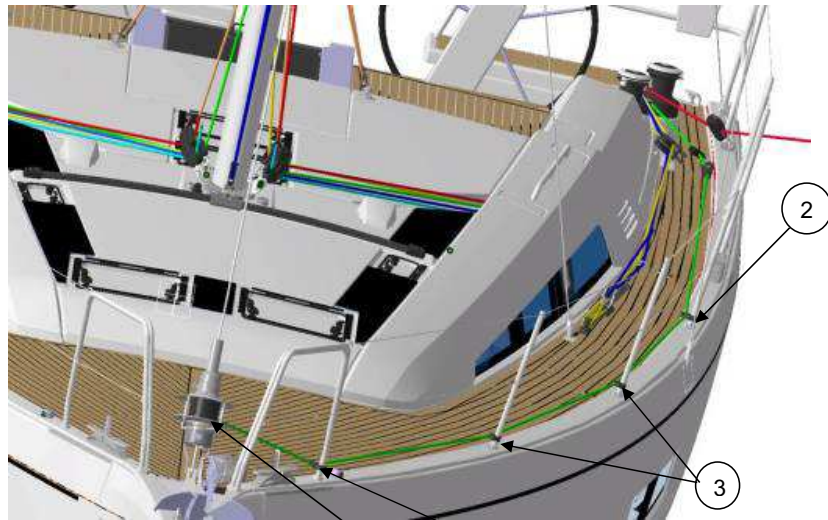

1

2

FIRST LINE

2

3

5

Reference	Designation
1	Furling drum kit
2	Stanchion block
3	Stanchion fairleads
5	Single pulley

Genoa traveller

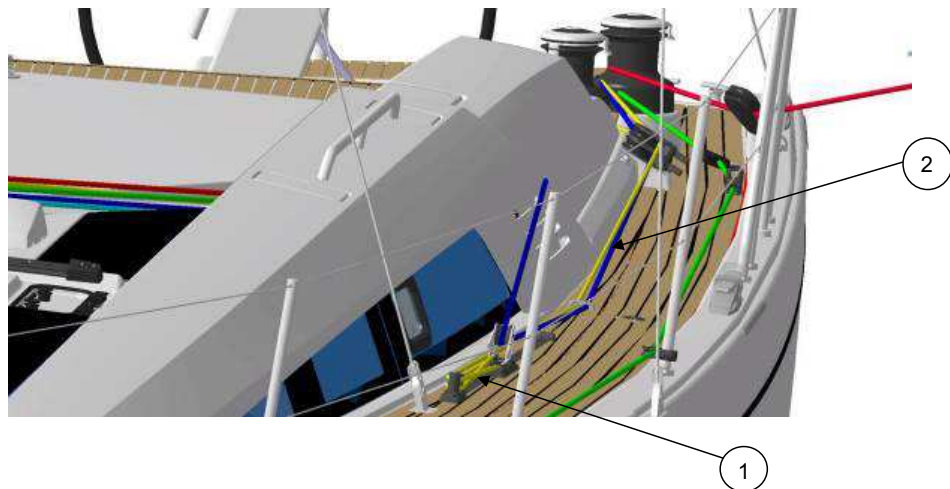

Reference	Designation
1	Genoa car adjustment
2	Genoa sheet

SELF-TACKING JIB

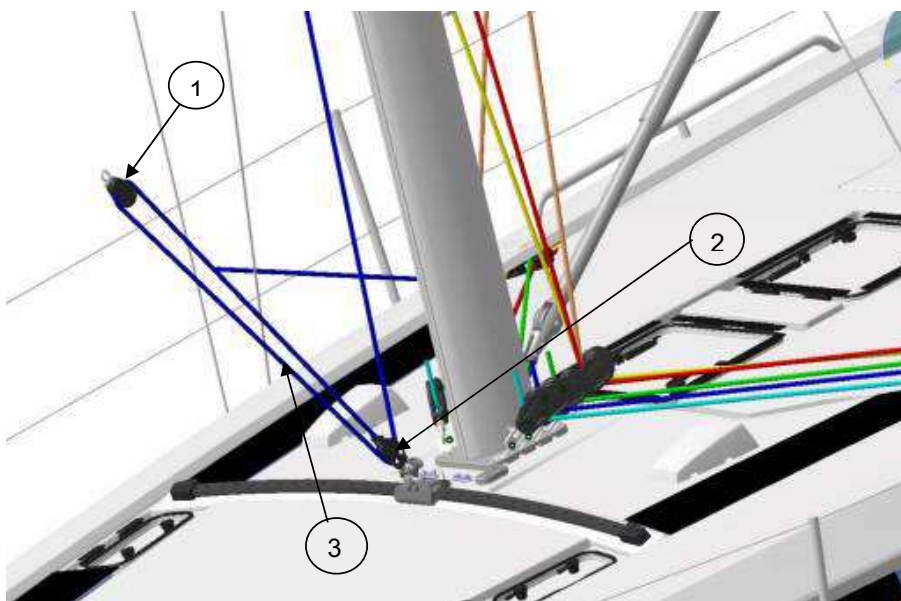

Reference	Designation
1	Single pulley
2	Single swivel pulley
3	Self-tacking jib sheet

ASYMMETRICAL SPINNAKER CIRCUIT / CIRCUIT CODE 0

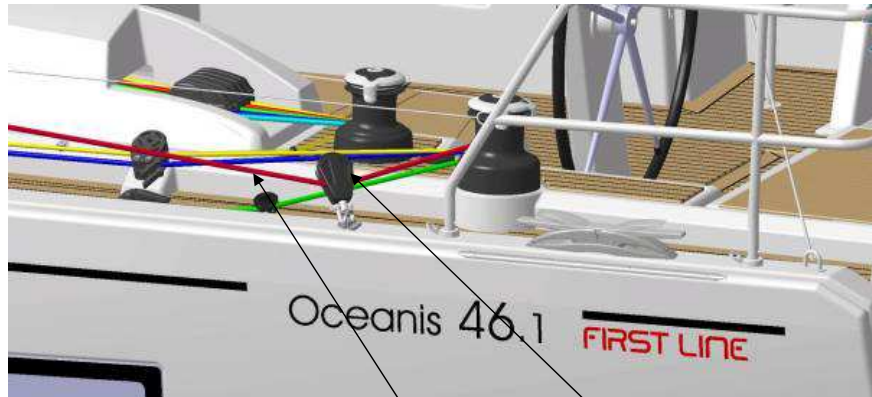

2

1

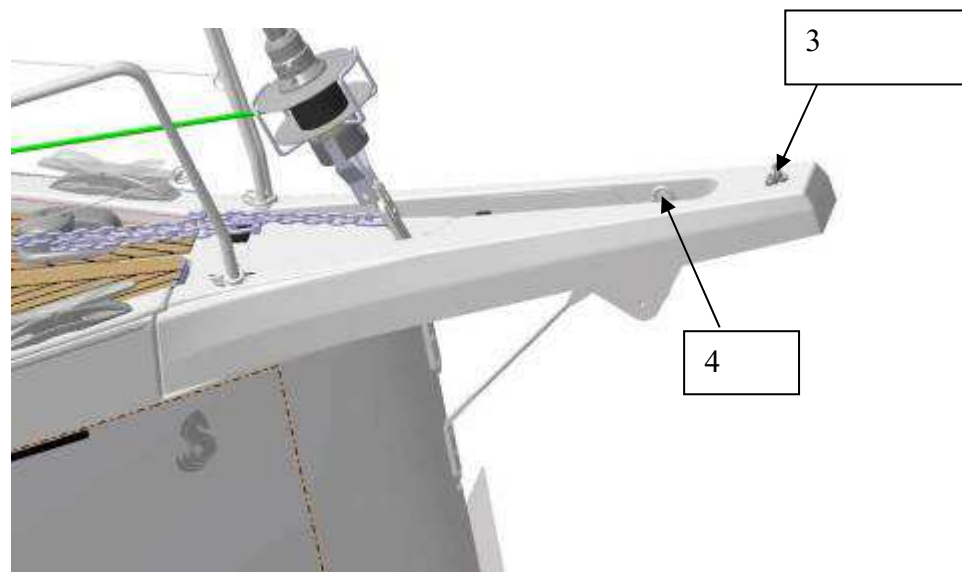

3

4

Reference	Designation
1	Single pulley
2	Asymmetrical spinnaker sheet
3	Asymmetric spinnaker tack
4	Code tack 0

5.6 DECK FITTINGS

General points

- Inspect each piece of deck gear regularly (blocks, shackles, swivels, cams, etc): Check that there is no cracking, corrosion or deformation.
- When replacing a piece of deck gear, make sure that you use a model with the same strength specifications.
- Failing to check deck fittings regularly and to replace worn ropes means that a block or hoist may suddenly break, causing an accident involving serious injury and damage to the boat.

Maintenance

- Upon return from sailing always rinse the deck fittings with fresh water.
- Wash deck gear regularly with a gentle soap, turning the sheaves of each block. Rinse afterwards with fresh water.
- Never use grease on deck fittings (except winches).
- Never use caustic-based cleaning materials on deck fittings (such as some teak cleaners).

5.7 WINCHES

Manual winches

- Do not leave loose ropes on the winches - secure them to cleats.

Electric winches

- The electric winches are powered by direct current.
- A breaker protects the electrical circuit.
- An operation relay is fitted to the electrical circuit.
- A load controller is fitted to the electrical circuit: This system protects the winches against overload by temporarily interrupting the electrical supply. The load controller is programmed in the factory.
- Inserting a winch handle into an unloaded winch automatically disconnects the motor transmission and allows it to be used manually.

NOTE:

- Operating the electrical winches requires heavy battery usage: Make sure the battery bank is systematically recharged after a day's sailing.



- The use of an electric winch for furling/unfurling the genoa or any other foreward sail must be strictly avoided (risk of the forestay breaking which may lead to dismasting).



- Refer to the manufacturer's instructions for use and maintenance.

- Avoid bulky clothing, long hair and jewellery that might become caught in the winch when it is moving. Avoid riding turns when using the winches.

Rinse winches regularly with fresh water

- Rinse winches regularly with fresh water.
- Dismantle, clean and lubricate each winch annually. Parts that have been damaged or worn may need replacing.

Access to the engine: Aft cabins



5.8 GENOA FURLER

Operation

- Leave several turns of the furling line around the drum.
- Furl/unfurl the genoa slowly so that the furling line is always under light tension, thus avoiding any riding turns in the drum.
- Never slacken the genoa halyard when furling/unfurling the sail.
- When furling in light winds, it is recommended that you keep the sheet under slight tension so that the genoa furls correctly.
- Furling and unfurling of the sail are carried out upwind.

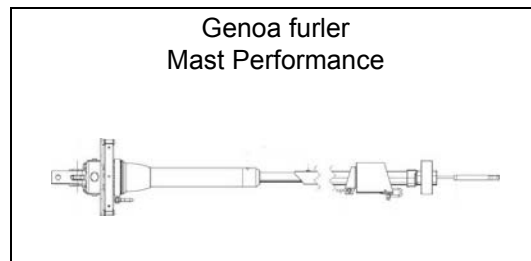
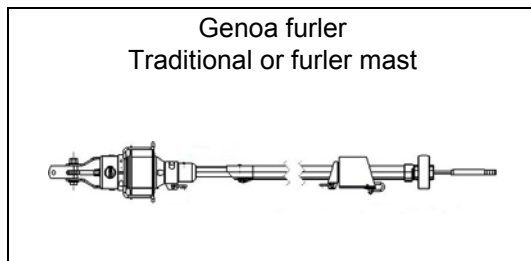

Maintenance

- Rinse the furling drum regularly.
- It is recommended that you rinse mechanical parts at least once a year with fresh water.

5.9 SINGLE LINE FURLER

- The jib furler differs in use from roller reefing gear: The foresail is either completely furled or completely unfurled. It is not possible to reduce the sail plan using the jib furler as can be done with roller reefing gear.
- Furling and unfurling is carried out downwind.

Maintenance

- Rinse the drum regularly.
- It is recommended that you rinse mechanical parts at least once a year with fresh water.

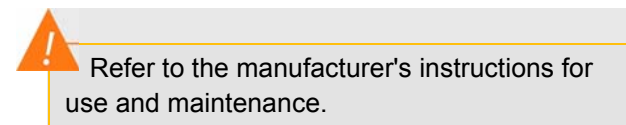

SAFETY

- Preventing man overboard situations and means of reboarding 46
- Storing the liferaft..... 50
- Securing moveable items 51
- Deck Layout 52
- Information on flooding risks and boat stability 53
- Emergency systems in case of steering gear failure..... 60
- Information on lightning-related risks..... 61

6.1 PREVENTING MAN OVERBOARD SITUATIONS AND MEANS OF REBOARDING

6.1.1 Prevention of man overboard

- The off-limits areas of the working deck when under way are cross-hatched below



- "Working deck" refers to the exterior parts of the boat where people stand or walk during normal use.



Use the seats provided.

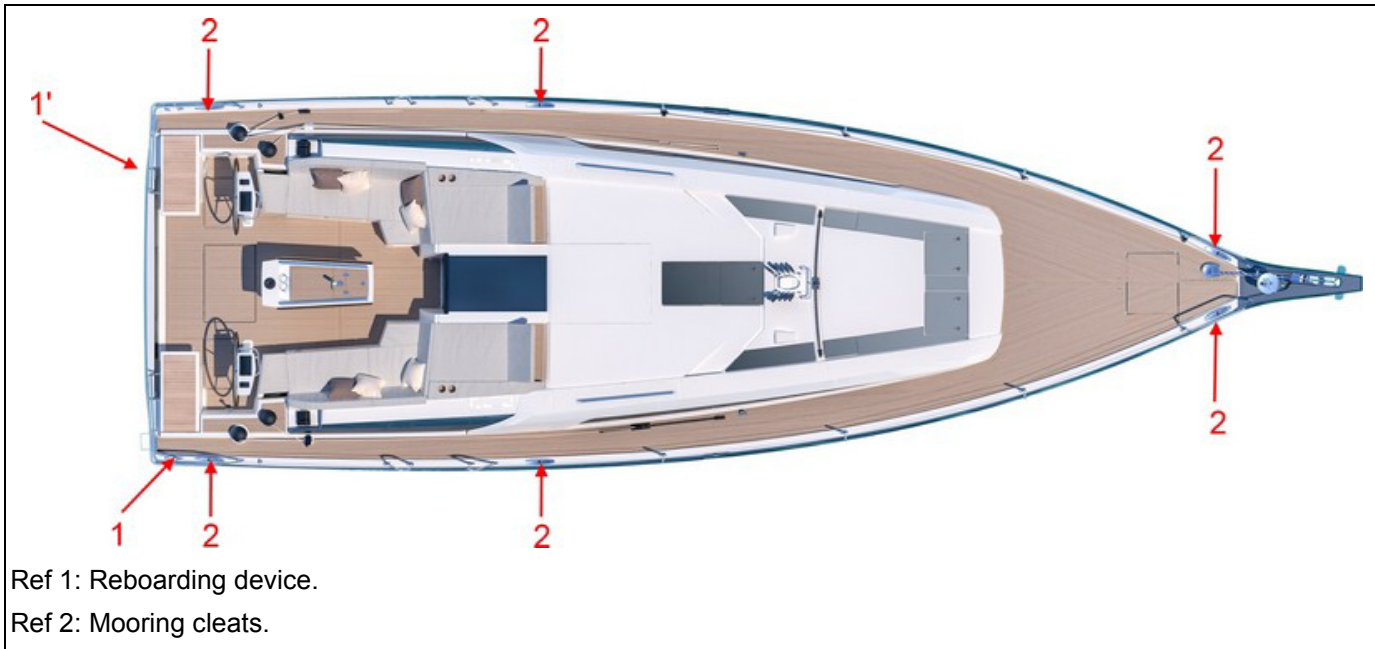

Regularly check the tension of the lifelines and the attachment points.

Regularly check the guardrails:

- With metal guardrails look out for signs of corrosion (particularly at connecting points).
- With synthetic guardrails, change them as soon as they show signs of wear due to chafing or UV.

6.1.2 Reboarding

A reboarding device must be usable from the water by a single person with no external help.

Configuration of reboarding device:
Swimming ladder (Ref 1'):

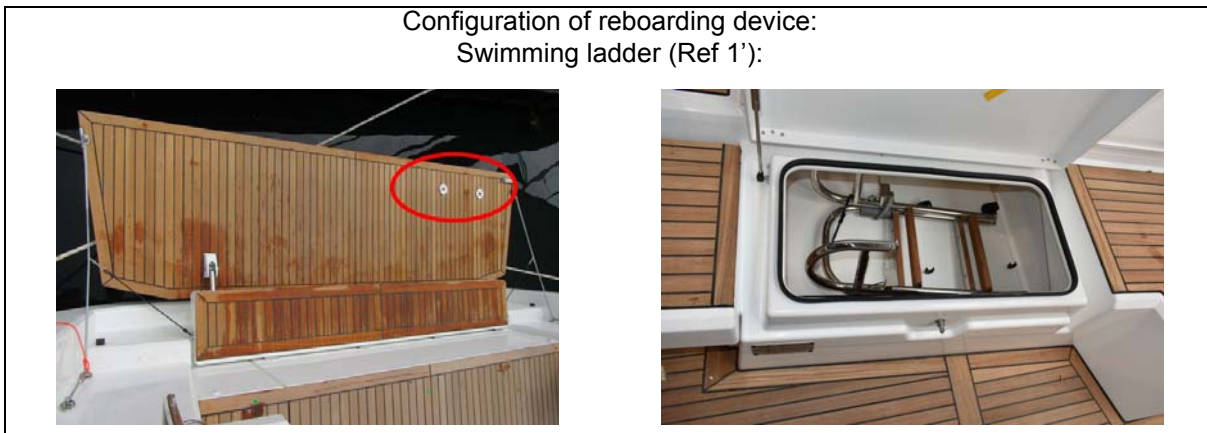

- Some types of reboarding equipment have a locking device when folded up: It is important to keep the means for getting back onboard deployed and ready to use once the boat is in use (at anchor, moored or at sea).
- Make sure that means for getting back onboard are readily accessible and easy to use by someone alone in the water.
- Before using your boat, make sure the safety ladder is in its place.



- Make sure your safety ladder is installed in accordance with the installation diagram.
- Make sure the triggering line is installed in accordance with the installation diagram.

AVERTISSEMENT

Veillez à ce que l'échelle souple soit installée conformément aux instructions du Manuel Propriétaire. Veillez également à ce que le bout déclencheur soit mis à poste conformément aux instructions.

WARNING

Make sure that the flexible ladder is installed as specified in the Owner's Manual. Also make sure that the rope trigger is installed in accordance with the instructions.

Configuration of reboarding device in the event of an accidental fall (Ref 1):



Assembling the ladder:

- Take the ladder out of its case and attach the ladder by tying a lark's head knot. The knot must face outside.
- Place the flap of the case between the loop of the ladder and the first step.
- Screw on the flap with the two bolts and nuts on the back. The nuts should be on the back of the case to ensure they do not prevent the ladder from being taken out for use.
- Adjust the length of the cord to reach the water level and check that the ladder is properly released. It is important to ensure that the ladder extends smoothly into the water. Attach the end of the cord to the swivel plate provided for this purpose. Finally stow away the ladder and close the internal flap with the press studs.

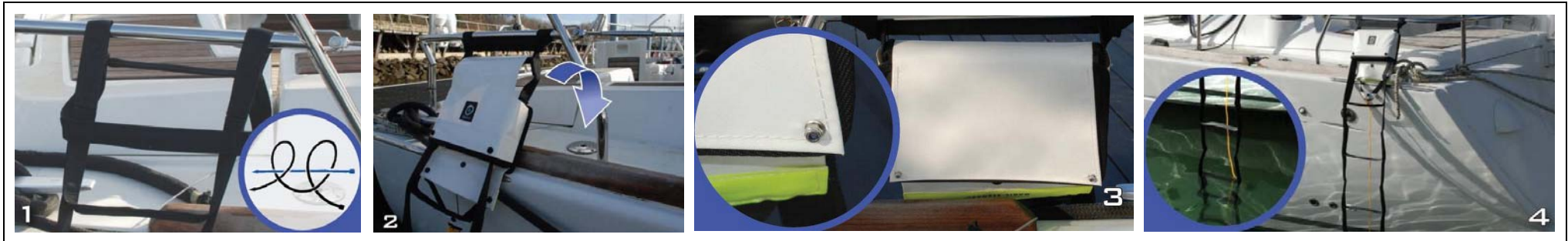

6.2 STORING THE LIFERAFT



The liferaft (not supplied) must be stored in the space provided for it (Ref 1). A pictogram allows for easy location.



- ! - Before putting to sea, carefully read the launching instructions shown on the liferaft.
- It is the responsibility of the skipper to ensure regularly that the liferaft is properly secured in place.

6.3 SECURING MOVEABLE ITEMS

The technical areas are identified in the boat by the pictogram below:



The electrical technical areas are identified in the boat by the pictogram below:



Technical areas may not be used as storage compartments.



- Ensure that movable items are firmly secured when sailing.
- Do not store anything below the floorboards.

6.4 DECK LAYOUT



! The maximum weight of the outboard engine on the pushpits must not exceed 20 kg.

6.5 INFORMATION ON FLOODING RISKS AND BOAT STABILITY

6.5.1 Hull openings

Valves, thru-hull inlets and other brass or bronze fittings have a lifespan of around 5 years. All valves, thru-hull inlets and other brass or bronze accessories must be checked by a professional every year and replaced as necessary.

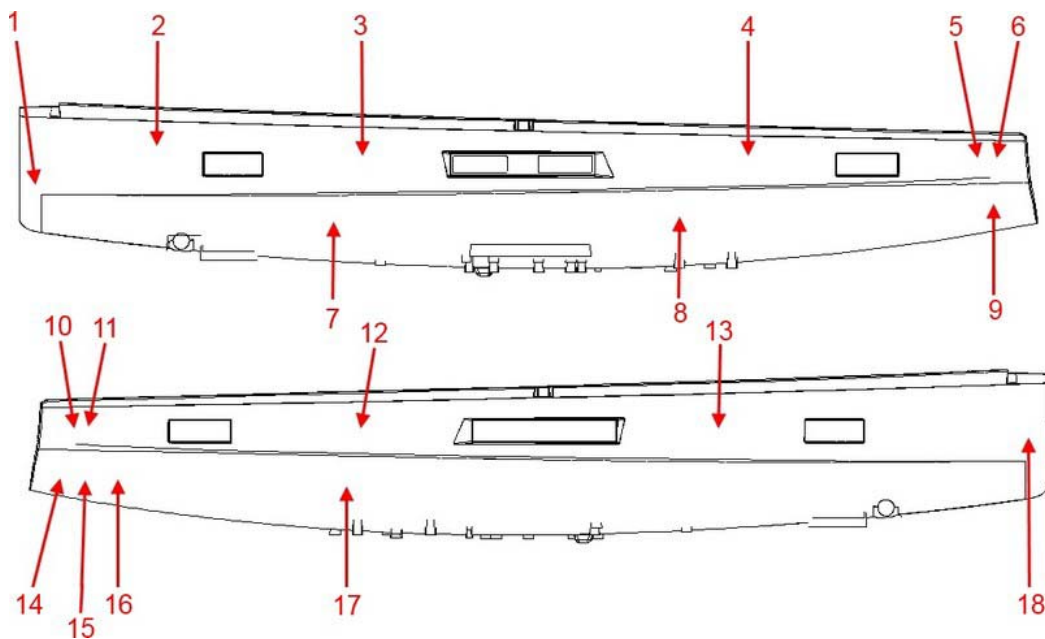

Reference	Designation	Valve
1	Chain locker scupper	No
2	Water tank vent	No
3	Blackwater tank vent	No
4	Blackwater tank vent	No
5	Fuel tank vent	No
6	Port boiler exhaust	No
7	Washbasin drainage	No
8	Washbasin drainage	No
9	Engine exhaust	No
10	Starboard boiler exhaust	No
11	Additional tank vent (Water / Fuel)	No
12	Blackwater tank vent	No
13	Blackwater tank vent	No
14	Generator exhaust	No
15	Air conditioning drainage (x 4)	Yes
16	Watermaker outlet	Yes
17	Washbasin drainage	Yes
18	Chain locker scupper	No

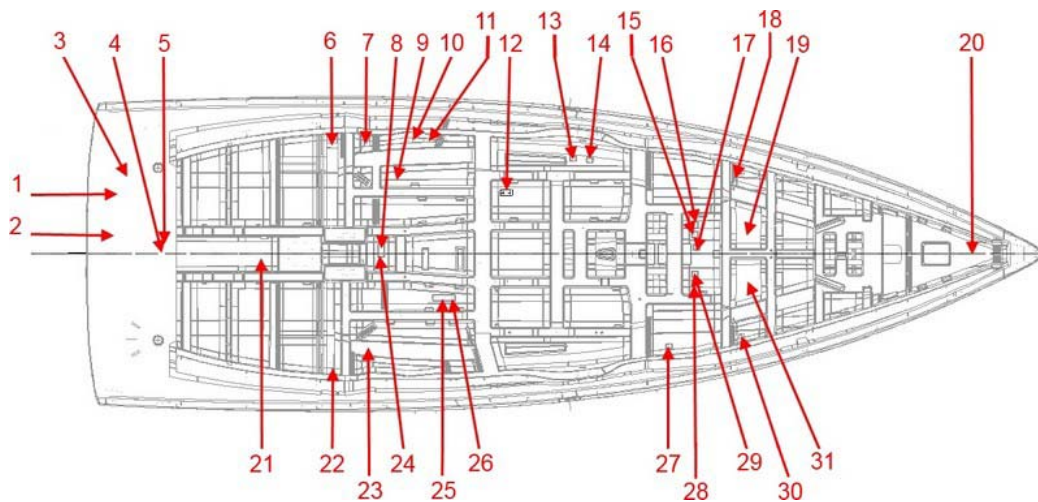

Reference	Designation	Valve
1	Electric bilge pump drainage	No
2	Drainage of manual bilge pump	No
3	Seawater drainage - Generator	Yes
4	Earthing plate - DC/AC converter	No
5	Earthing plate - Generator	No
6	Drainage of blackwater tank into the sea	Yes
7	Shower drainage	Yes
8	Seawater intake - Watermaker	Yes
9	Dishwasher drainage	Yes
10	Sink drainage	No
11	Seawater intake - Foot pump (3 cabins 2 heads version)	Yes
12	Seawater intake - Toilet	Yes
13	Seawater intake - Foot pump	Yes
14	Sink drainage	No
15	Seawater intake - Toilet	Yes
16	Shower drainage	Yes
17	Seawater intake - Air conditioning	Yes
18	Drainage of blackwater tank into the sea	Yes
19	Electronic sensor "Forward Scan"	No
20	Seawater intake - Deck wash pump	Yes
21	Cockpit fridge condenser	No
22	Drainage of blackwater tank into the sea	Yes
23	Shower drainage	Yes
24	Seawater intake - Generator	Yes
25	Seawater intake - Toilet	Yes
26	Seawater intake - Air conditioning	Yes
27	Head washbasin drainage	Yes
28	Shower drainage	Yes
29	Seawater intake - Toilet	Yes
30	Blackwater drainage tank - Toilet	Yes
31	Tri-function sensor	No

6.5.2 Drainage system

General points

- The inner moulding of the hull is equipped with channels: these are the drainage channels. The drainage channels allow the water to drain down to the lowest point in the boat, where it can be discharged. It is important to allow the water to flow freely down to this lowest point of the boat, which means.
- regularly cleaning the lowest point of the boat and the drainage channels.

DIAGRAM OF LAYOUT - DRAINAGE CHANNELS

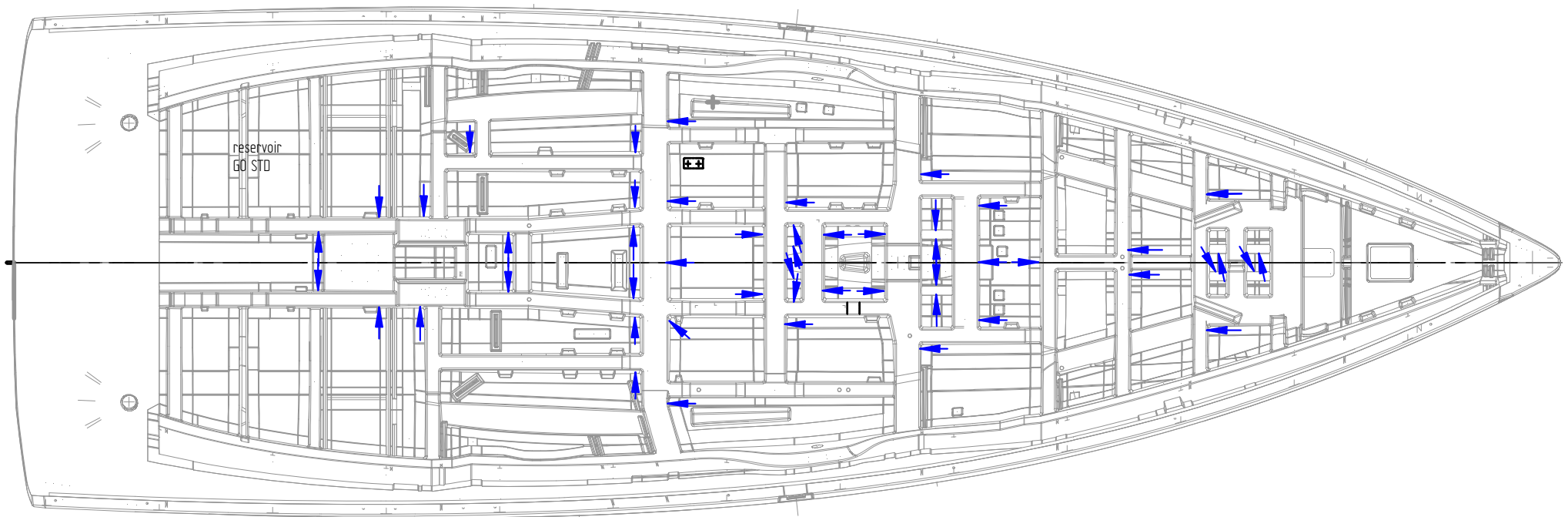
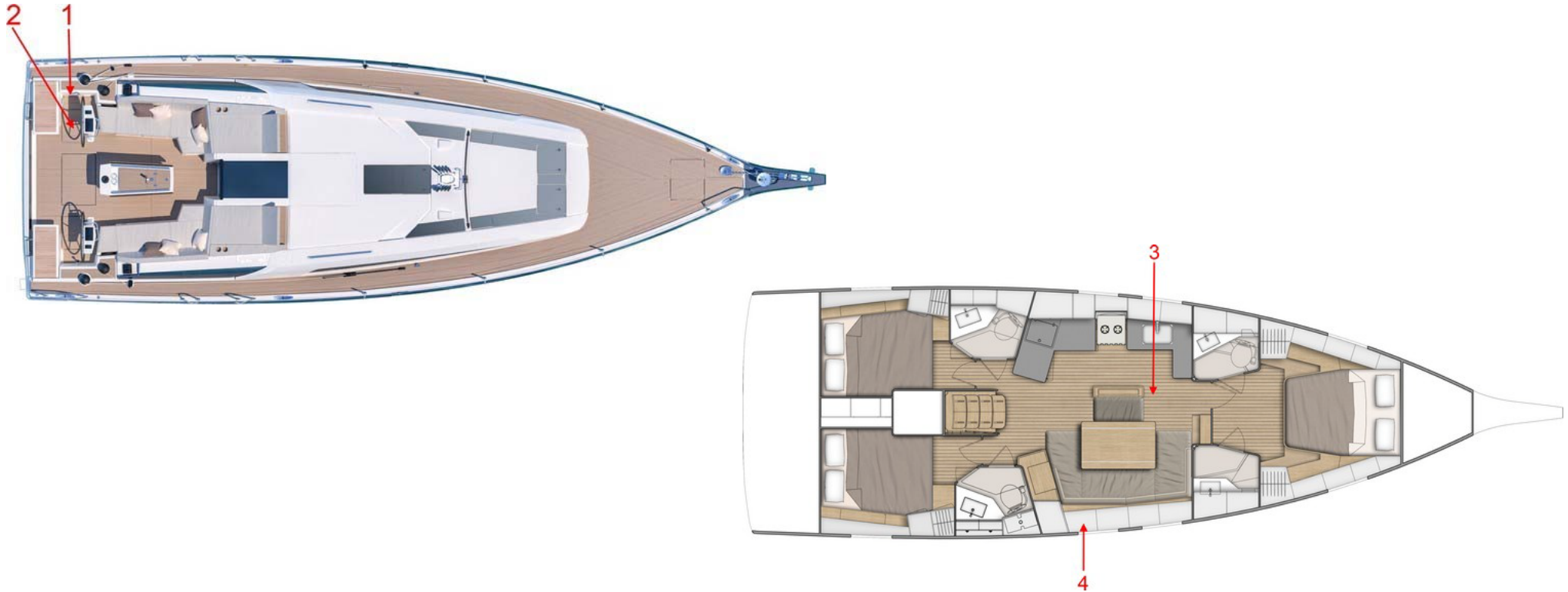

DIAGRAM OF LAYOUT - BILGE PUMPS



Reference	Designation	Rate
1	Manual bilge pump	32L/minute (*)
2	Manual bilge pump lever	
3	Electric bilge pump	45L/minute
4	Electric bilge pump switch	

(*) 45 strokes/minute

Secondary drainage system **Manual bilge pump**

The manual bilge pump is in the cockpit (Ref 1).

The bilge pump lever is located nearby (Ref 2).



Operation:



I- Attach the lever to the manual bilge pump.

II- Repeatedly work the lever up and down to its fullest extent.

The manual bilge pump lever must remain accessible at all times.

Main drainage system Electric bilge pumps

- The bilge pumps are powered by DC.

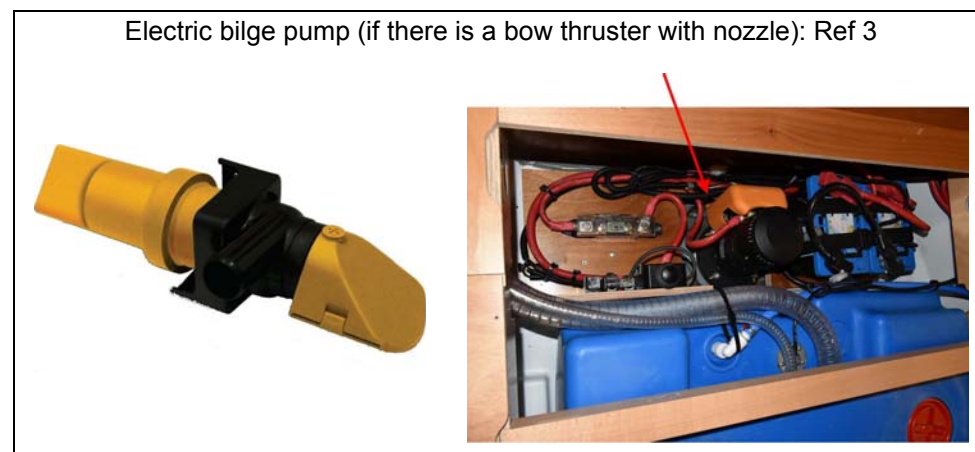
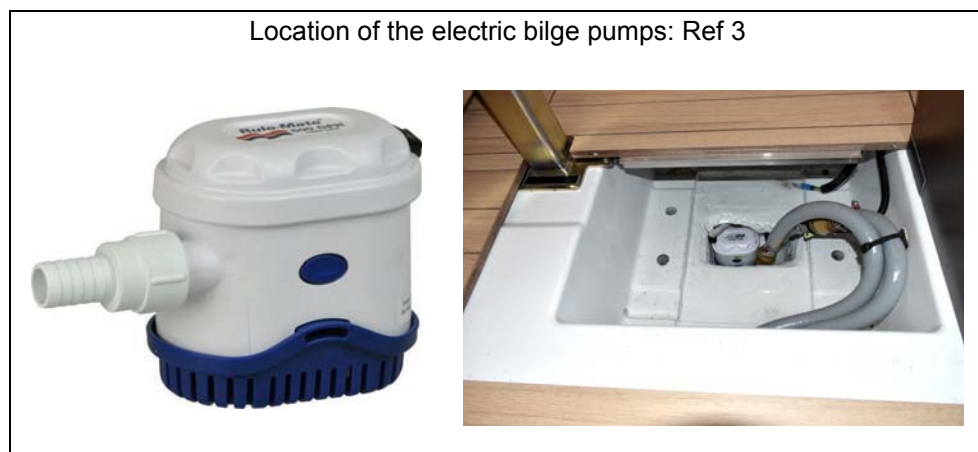

- The switch for the electric bilge pump is located on the switch panel (Ref 4).

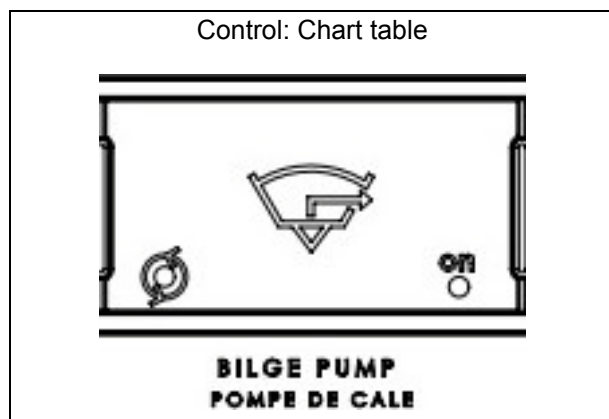

- Pressing the switch once activates the "automatic" mode of the bilge pump: The pictogram lights up red.
- Pressing the switch twice activates the "forced run" mode of the bilge pump: The indicator light ON turns on (bottom right).
- When the indicator light on the bottom left lights up, the bilge pump is in operation.

- The electric bilge pump must only be used to discharge stagnant water at the bottom of the bilge. It must not be used to pump out any oil-based products (petrol, oil) or inflammable liquids.

Operation:

- I- Turn on the battery switches.
- II- Switch on the bilge pump (Ref 4).

If the boat is equipped with an automatic bilge pump, the switch has an always-on position.

Bilge pump maintenance

Please refer to the manufacturer's notes in the instructions for checking and maintaining the bilge pumps.

DIAGRAM OF LAYOUT - DRYING OUT THE BILGE

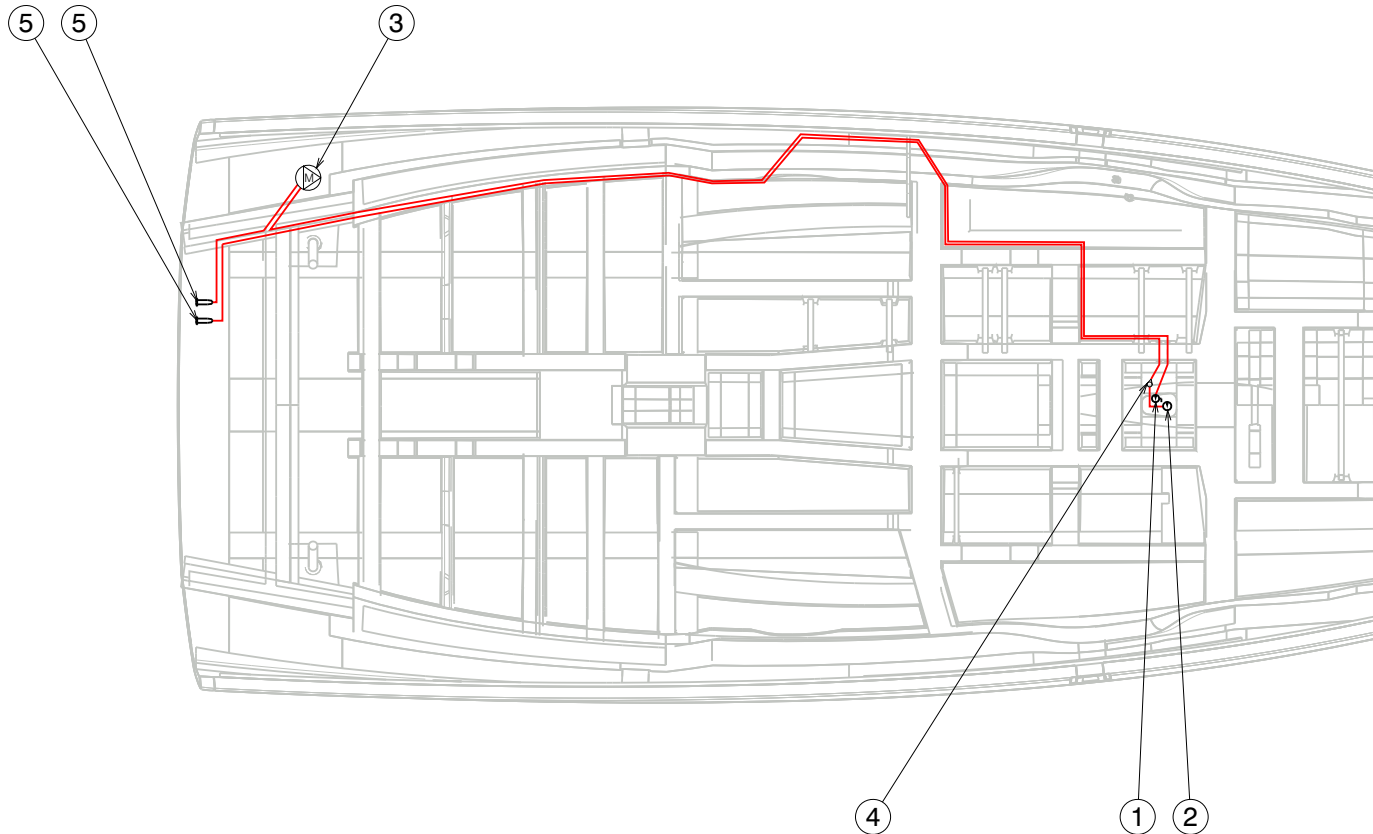

Reference	Designation
1	Intake filter
2	Electric bilge pump
3	Manual bilge pump
4	Non-return valve
5	Kitchen sink thru-hull drainage

!

- The drainage system is not designed to control water coming from breaches in the hull.
- Keep the water level in the bilges to a minimum.
- Never store anything at the very bottom of the boat: Allow bilge water to flow freely down to the lowest point of the boat.

!

- Check that each bilge pump is working at regular intervals.
- Clear the points and suction filters of the bilge pump of any debris that could clog them.
- If the watertight partitions which seal off the fore and aft points are fitted with valves they must be closed at all times and only opened to drain water into the main bilge.

6.6 EMERGENCY SYSTEMS IN CASE OF STEERING GEAR FAILURE

Emergency tiller

The emergency tiller is designed only to enable navigation at a reduced speed in case of steering gear failure.

Location of components

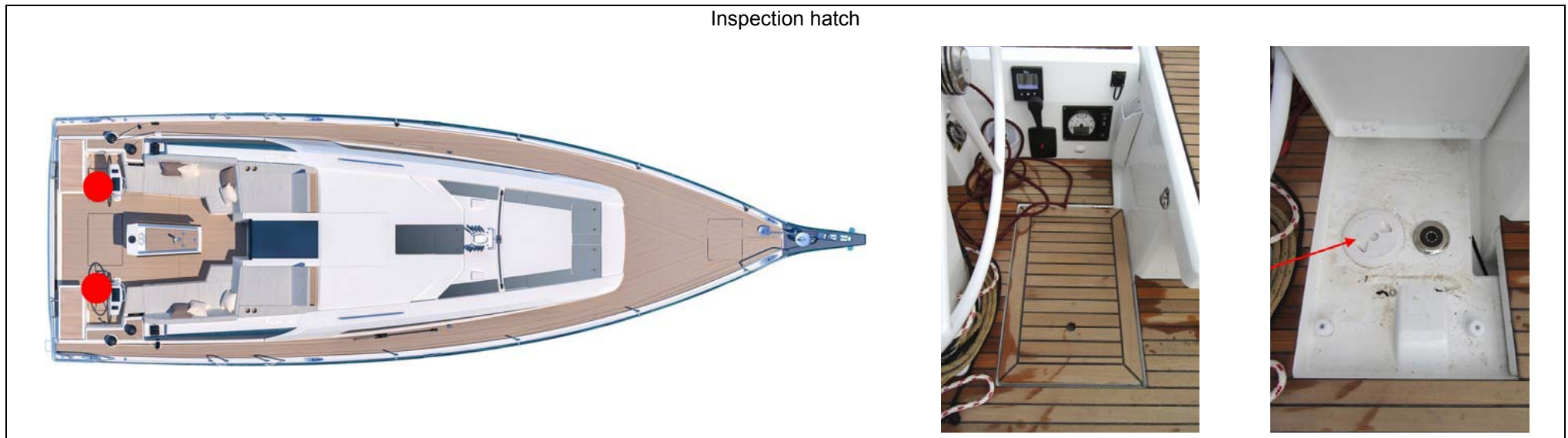

Instructions in the event of steering gear failure

- I. Unscrew the access hatch using a winch crank handle.
- II. Fit the emergency tiller (Ref 2) in the square on the rudder post.

6.7 INFORMATION ON LIGHTNING-RELATED RISKS

- The skipper must check the weather conditions before deciding to put to sea. If there is a risk of thunderstorms, the skipper must avoid putting to sea.
- A lightning safety device is installed on the boat.
- An earth braid connects the mast foot to the keel.

Precautions to be taken by the occupants of the boat during a storm

- Ensuring the safety of everyone on board is the fundamental goal of lightning protection.
- Turn off the engine, turn off the battery switches and disconnect all electronic and electrical equipment, including equipment mounted on the mast.
- Occupants should stay as much as possible inside the closed vessel.
- Occupants should not be in the water or let their arms or legs hang in the water.
- Occupants should avoid touching any part connected to a lightning protection device, especially in such a way that the parts become connected.
- Occupants must avoid contact with the metal parts of the rigging, spars, deck fittings and boat wiring. Even inside the boat, occupants should stay as far as possible away from the mast.

Maintenance

- Flexible radio antennas should not be tied down during a thunderstorm.
- If the boat has been struck by lightning, the compass and electronic and electrical equipment must be examined to determine whether any damage or calibration change has occurred.
- If the vessel has been struck by lightning, the lightning protection device must be inspected for damage and to verify the integrity of the device and continuity of the earthing.

INFORMATION RELATING TO FIRE RISKS AND RISKS OF EXPLOSION

- Propulsion engines and other fuel-burning equipment..... 64
- Electrical system 64
- Gas system 64
- Fire fighting and prevention equipment..... 65
- Emergency exits in case of fire..... 71

7.1 PROPULSION ENGINES AND OTHER FUEL-BURNING EQUIPMENT

 The risks associated with motorisation are described in the **ENGINE** chapter.

Note concerning the boat's tender:

- If the tender is fitted with a more powerful outboard motor than 25kW, it must have on board a portable extinguisher with a rating equal to or greater than 8A / 68B.
- Place for storage of tender petrol tank: on deck.

 The risks associated with other fuel-burning equipment are described in the **FUEL-BURNING EQUIPMENT OTHER THAN FOR PROPULSION** chapter.

7.2 ELECTRICAL SYSTEM

 The risks associated with the electrical systems are described in the **ELECTRICITY** chapter.

7.3 GAS SYSTEM

 The risks associated with the gas system are described in the **GAS** chapter.

7.4 FIRE FIGHTING AND PREVENTION EQUIPMENT

7.4.1 Fire-fighting equipment

Portable fire-extinguishers and fire blanket (not supplied)

- When in use, this boat must be equipped with portable fire extinguishers of the following extinguishing capacities, located in the following places:

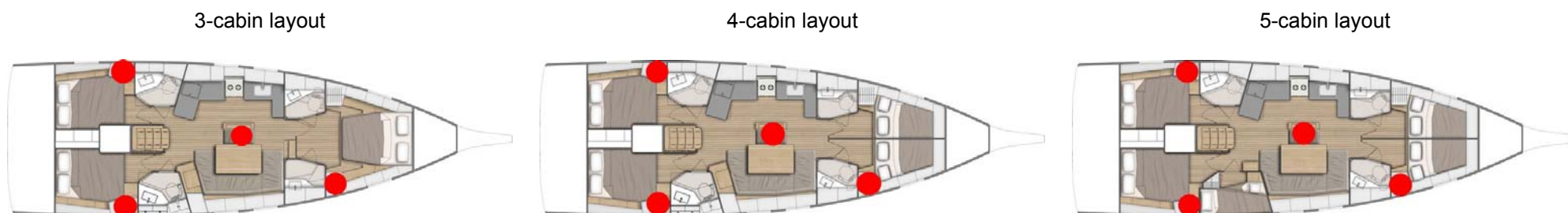

Location	Minimum extinguishing capacity
Port side aft cabin hanging locker	5A / 34B
Starboard aft cabin hanging locker	5A / 34B
Saloon	5A / 34B
Forward starboard cabin socket	5A / 34B

- The location of the portable fire extinguishers is shown by the pictogram below:



- When in use, this boat must be equipped with a fire blanket to protect the cooking equipment and/or the galley, installed in the following place: near the cooking equipment.

Maintenance of the fire-fighting equipment

The owner/person operating the boat must:

- Have fire-fighting equipment checked as frequently as recommended by the manufacturer;
- Replace portable fire extinguishers, if outdated or discharged, with extinguishing apparatus of equal capacity;
- Provide at least one fire bucket with a lanyard, in a readily accessible place, for protection of the deck;
- Have fixed fire extinguishing systems filled or replaced if they have been discharged or have expired.

Responsibility of the owner/boat operator

It is the responsibility of the owner/boat operator to:

- Ensure that the fire-fighting equipment (portable extinguishers, bucket and fire blanket) is readily accessible when there are people onboard;
- Ensure that the engine compartment fire extinguisher discharge port is readily accessible;
- Show the members of the crew:
 - The location and use of the fire-fighting equipment;
 - Location of discharge ports in engine compartment;
 - The location of evacuation routes and fire exits.
- Equip the vessel with one or more portable extinguishers whose heads are compatible with the diameter of the opening in vertical use.
- Unlock all deck hatches and fire escape openings when the vessel is occupied.



NEVER:

- Obstruct the passages leading to the emergency exits and the hatches;
- Obstruct or block safety controls, for instance fuel shut-off valves, gas taps, electrical system circuit-breakers;
- Obstruct the access to the portable extinguishers stored in lockers;
- Leave the boat unsupervised when cooking equipment and/or heating equipment is in use;
- Modify any of the boat's installations (especially the electrical, fuel or gas installations) or allow unqualified personnel to proceed with modifying these installations;
- Fill the fuel tanks or replace gas bottles while the engine is running or while cooking or heating equipment is in use;
- Use gas lamps in the boat;
- Smoke when handling fuel or gas;
- Obstruct the ventilation of the compartments or spaces, in particular those containing the engines, tanks or batteries.

Notes for the attention of the boat user

General points

- Check that the bilges are clean and frequently check that there are no fuel/gas vapours or fuel leaks.
- When replacing components of the fire-fighting equipment, use only appropriate components of the same code designation or with the equivalent technical capacity and fire resistance.
- Do not install free-hanging curtains or other fabrics near or above the cooking appliances or other equipment with a naked flame.
- Do not store combustible materials in the engine compartment. If non-combustible materials are stored in the engine compartment they must be secured so there is no danger of them falling on machinery and they do not obstruct access to and from the compartment.
- The **CO₂** extinguishers must only be used only to fight **electrical fires**.
- The fire exits other than the door or main companionway are identified by the following symbol:



7.4.2 Smoke alarm

General points

- The smoke detector is a photoelectric detector which operates with a 9 V alkaline battery (battery included).
 - The detector emits a flashing red light every minute in normal operation.
 - The smoke detector is designed to operate between 0° and + 50°C.
 - Whenever any smoke is detected, the 85 dB alarm is triggered.
 - The smoke detector is not designed to stop a fire from breaking out. It serves to warn the people onboard of the danger.
 - The detector is a device which warns people onboard in the event of smoke.
- Actions to take if the alarm is triggered: The skipper should check the source of the smoke and attempt to extinguish the fire with the resources at his/her disposal. If the fire spreads, the skipper must immediately evacuate the entire crew.
- The service life of the smoke detector is approximately 10 years. Beyond 10 years, replace the smoke detector with an identical device.



- The smoke detector is not a gas detector.
- The smoke detector is sensitive to dust and steam: avoid exposing the detector to these environments to prevent the triggering of unwanted alarms.
- Never use a rechargeable battery.
- Never trigger the alarm deliberately to check the operation of the detector.
- A dirty detector may activate incorrectly or late. It is important to clean each detector for the safety of people onboard.
- Never cover the smoke detector (with paint or ceiling panels, for example) and in general do not alter the appearance of the detector.
- Do not fit the smoke detector in a different location from the one specified for the purpose.

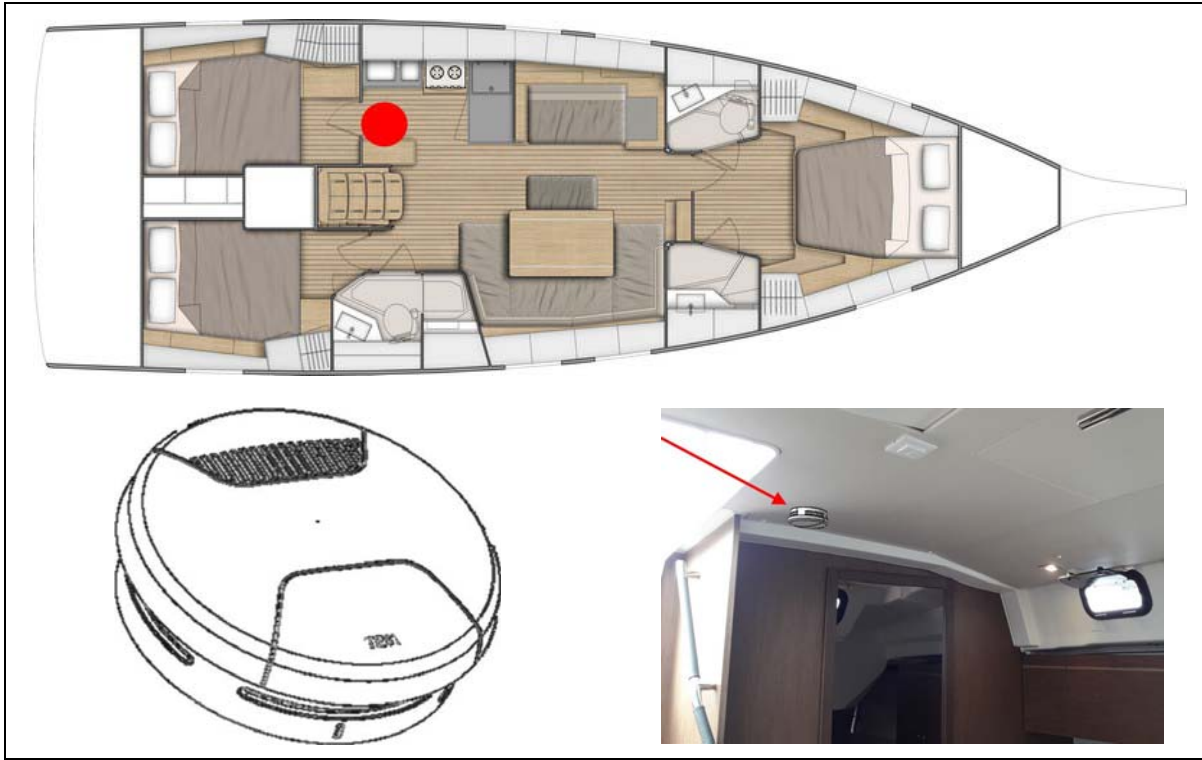

Commissioning of the boat

- When the boat is first delivered, ensure that the battery protector is removed.

Maintenance

The smoke detector must be routinely tested when boarding or weekly if staying onboard for a prolonged period of time. If the device is faulty, change the battery. If the device is still faulty after changing the battery, replace the detector with the same model (consult your dealer).

- **TEST button**

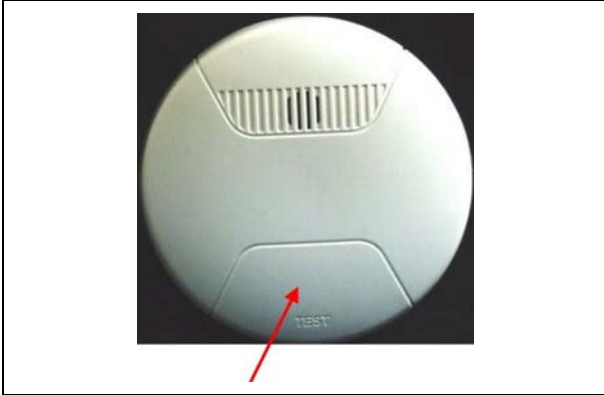

- Regularly check that each detector is working correctly by pressing and holding the device's TEST button for around ten seconds:

- The detector's light flashes, then the alarm starts up.

NOTE: The alarm emits a very loud noise (approximately 94 dB at one metre), remember to use hearing protection during the test.

- When the TEST button is released, the alarm stops immediately.

- **Changing the battery**

- The smoke detector will emit an audible beep every minute for a month when the battery level is too low to operate.

- In that case, change the battery as described below:

- Remove the detector from its mounting (turn anti-clockwise), remove the empty battery and replace it with the same model of alkaline 9 V battery, ensuring a battery life of 5 years.

- Connect the battery as shown in its housing (ensure the battery polarity +/- is correct).

- Return the detector to its mounting (turn clockwise) until it fits perfectly.

- **Annual routine maintenance**

- Remove the detector from its housing (turn anti-clockwise) and clean the vents on the side of the device with a vacuum cleaner or a soft brush.

- Use a damp cloth to clean the exterior of the detector cover.

Winterisation

- To ensure optimal operation, it is recommended that the smoke detector is stored for winter in a fresh and well-ventilated place, having removed the battery.

- Once one person is onboard, it is important to replace the smoke detector in the position specified for the purpose, having first reinstalled the battery.

7.4.3 Extinguisher access port (Engine compartment)

The engine compartment has a port that makes it possible to discharge the extinguishing product inside without opening the usual access hatches.

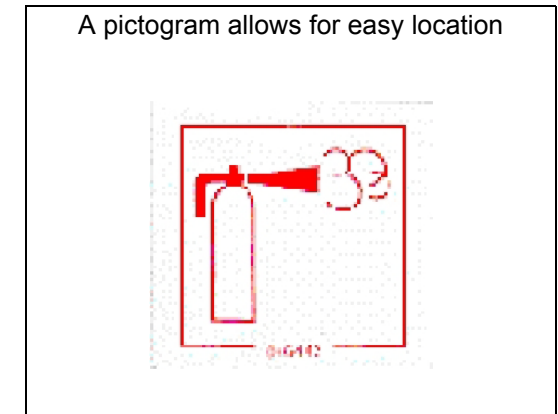
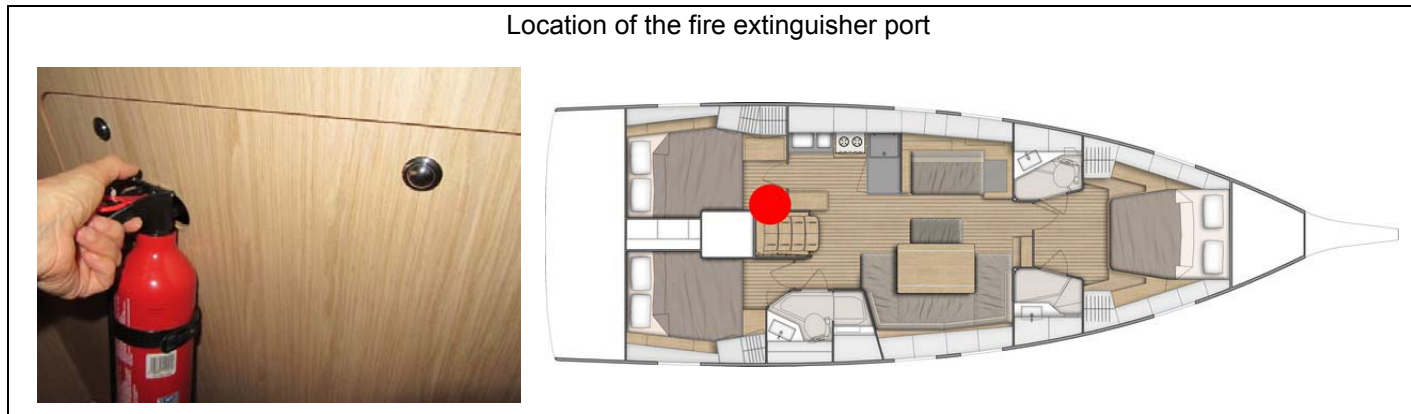

7.5 EMERGENCY EXITS IN CASE OF FIRE

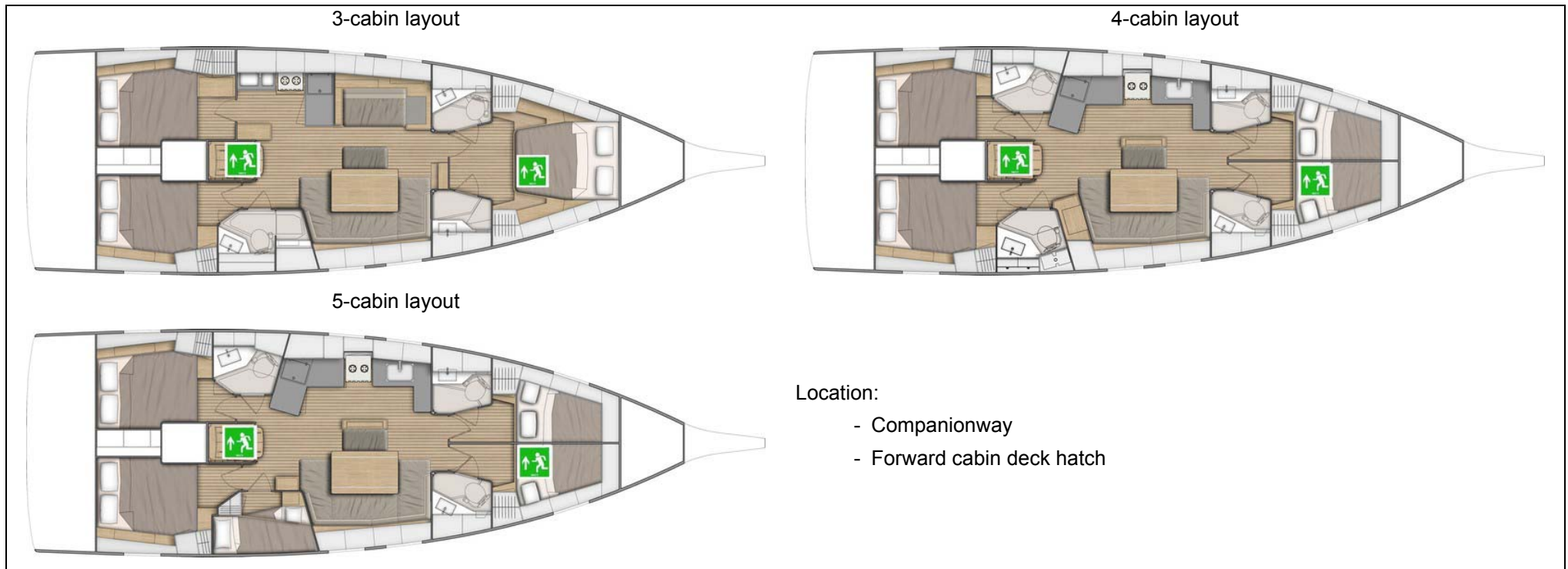

To get out by the deck panel of the front cabin, you are advised to stack the two mattresses of the bed on top of each other, to act as a step and make getting out easier.

ELECTRICAL SYSTEM

■ General information about the electrical system	74
■ DC installation (12V or 24V).....	75
■ Touch screen	91
■ AC system (110V or 220V)	102
■ Protection against electrolysis / Earth plate.....	115

8.1 GENERAL INFORMATION ABOUT THE ELECTRICAL SYSTEM

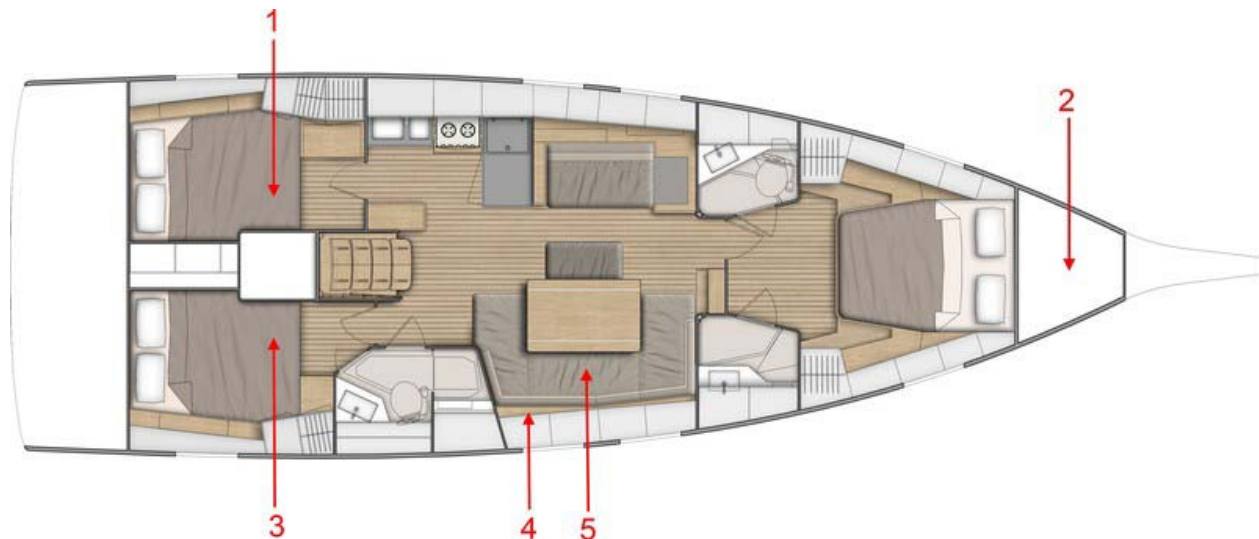

Reference	Designation
1	Additional service batteries
2	Bow thruster batteries
3	Service batteries, Engine battery, Battery switches, Power distributor, Battery chargers, Circuit breakers
4	Electrical panel, Circuit breakers
5	Fuses



- A risk of fire or explosion may result from careless use of the DC and AC systems.
- A risk of electrocution may result from careless use of the AC system.



NEVER:

- work on a live electrical system;
- modify the electrical system of the vessel or the relevant diagrams: It is important that installation, maintenance and any modifications be carried out by a qualified marine electrician;
 - change or modify the strength of the safety devices protecting against power surges;
 - install or replace electrical equipment or materials with components which exceed the system's nominal electrical power capacity;
 - leave the boat unsupervised when the electrical system is live, apart from when the automatic bilge pump and the boat's fire protection and security system are in use (where installed).



Electrical connections change over time. It is necessary to have the boat's electrics checked regularly and at least once every two years by a professional. Special attention should be paid to the tightness of the electrical connections.

8.2 DC INSTALLATION (12V OR 24V)

8.2.1 Battery use and distribution

General points

The boat is equipped with a direct current electrical system.

The boat's electrical system comprises service batteries and the engine battery or batteries. The service batteries serve as the power supply for all the boat's electrical components. The "engine" battery is used only for powering the electric starter of the propulsion engine.

The boat may also be equipped with:

- a generator powered by its own battery;
- a bow thruster, powered by its own battery bank.

the batteries are charged either by a load distributor or:

- by the alternator linked to the engine when the engine is running,
- by the battery charger (where installed).

It is essential that a professional engineer connects the batteries when the boat is first launched.

Always check the condition of the batteries and charge system before putting to sea.

The battery banks are isolated from one another by a charge divider (see below).

Battery bank

Engine battery: 1 x 120A



Service batteries: 2 x 120A



Spare service batteries: 3 x 100A



Propeller battery: 2 x 50A



Maintenance

- Keep the batteries clean and dry.
- Regularly check that the terminals and connection cables are clean. If necessary, apply a thin coating of paraffin on the terminals to prevent corrosion.
- Regularly recharge all of the batteries onboard.
- Keep the batteries charged at all times: this will improve their lifespan.
- Avoid long periods of electrical inactivity (for example when wintering the boat).

Maintenance of lead batteries

- Check the water levels in the batteries annually and top them up with distilled water if they are low.
- Keep all metallic objects away from the batteries.
- Lead batteries contain sulphuric acid: be careful not to knock them over whenever handling them.

Maintenance of watertight batteries

- This type of battery needs no maintenance and does not produce any gas during normal use. No ventilation is needed.
- The optimum temperature for use is between 10°C and 30°C. Lower temperatures will reduce the available capacity. Higher temperatures will increase the batteries' self-discharge rate.
- Never open watertight batteries.
- Never add acid or distilled water.
- The pressure valves are used to seal the batteries and cannot be opened without being permanently broken.
- If the batteries overheat, a build-up of gas may develop: stay away from the batteries.



- All work carried out on a battery must only be carried out by someone qualified to do so. Whenever working on a battery, wear safety goggles and protective clothing.
 - Never smoke or produce a spark near a battery: this may cause an explosion.
 - If any acid accidentally splashes on your skin or in your eyes, rinse it off immediately and thoroughly with fresh water. See a doctor immediately.
 - Never touch the battery terminals: you may suffer an electric shock.
 - Refer to the manufacturer's instructions for use and maintenance.
 - **It is essential that you disconnect the battery charger before disconnecting the battery terminals for maintenance (either by disconnecting the AC shore power socket or by cutting the AC circuit breaker of the battery charger).**

8.2.2 Battery switches

Manual battery switches: to make the system live, manually turn the positive and negative battery isolator switches.

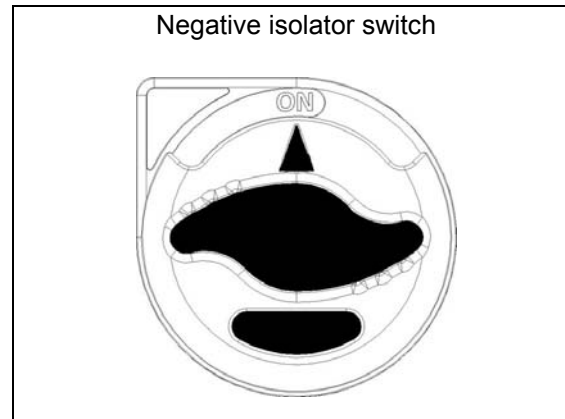
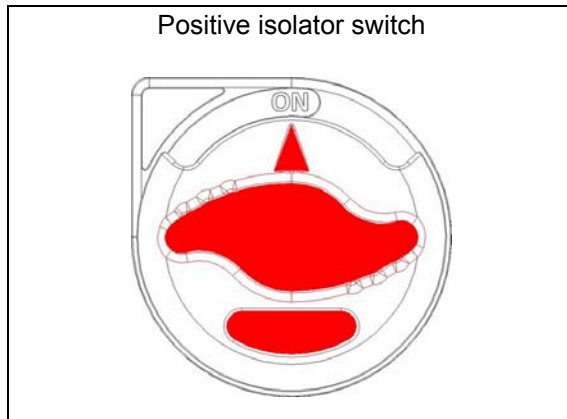

Location: Starboard aft cabin



1. Engine battery positive isolator switch
2. Common battery negative isolator switch
3. Service batteries positive isolator switch

- !**
- Turn off all battery isolators before leaving the vessel: **failure to do so may result in critical damage to the entire battery bank.**
 - Avoid touching the battery isolators when they are live.
 - Never switch off the battery isolators when the boat's engine is running (risk of serious damage to the charging circuit).

Electrically controlled battery isolators (Bow thruster): In the event of electrical failure, it is possible to press the button on top of the battery breaker down manually to activate it.

- The electrically-controlled battery breakers use very little electricity when they are on: **it is essential to turn off all the battery breakers during lengthy absences to prevent the batteries from slowly and irreversibly discharging.**
- The engine's positive battery isolator automatically switches on and off when the engine is started/stopped.
- The negative of the circuit is connected to the general negative.

Location: Sail locker

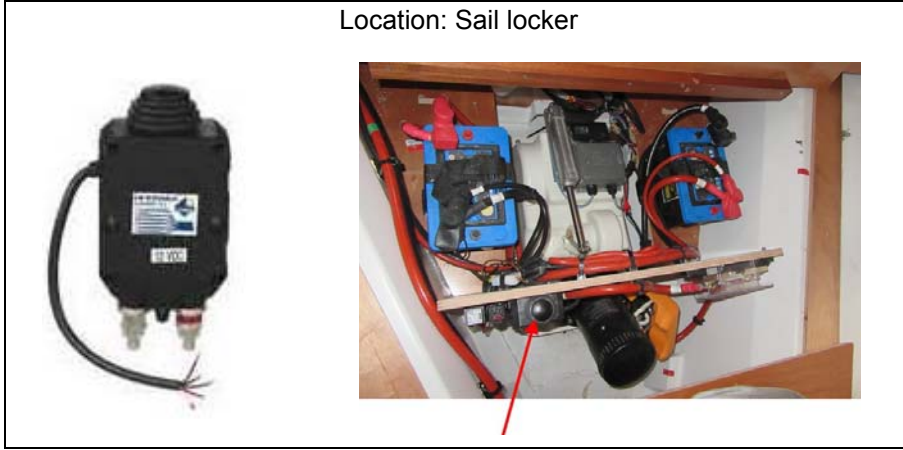

8.2.3 Power distributor

- The electronic charge dividers isolate the battery banks from each other and allow the charge to be directed automatically to the battery with the lowest charge. They provide the advantage of preventing a drop in voltage.
- The charge divider is electronic. It is designed to distribute the charging current with a low voltage drop between the battery banks (engine and service batteries). It prevents the current from circulating from one battery to another. When the voltage of the charger or alternator is available, the charge divider indicator lights up green.

Location: Starboard aft cabin

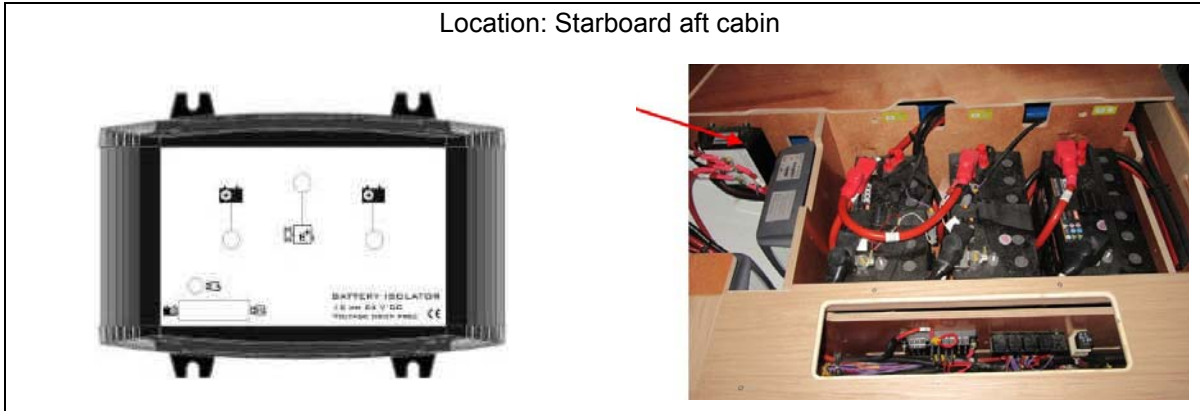

8.2.4 Battery charger

General points

- The battery charger runs on AC power.
- A breaker protects the electrical circuit.
- The battery charger charges all of the batteries onboard while keeping the service battery bank isolated from the engine's battery bank.

Location: Starboard aft cabin
Capacity: 2 x 40A



Operation

- The charger runs fully automatically. It can stay permanently connected to the batteries and does not need to be disconnected when starting the engine.
- In some electrical circuits, there may be battery chargers coupled in parallel.

Maintenance

- Before doing any maintenance, cut the AC supply.
- Regularly vacuum out any dust particles which may accumulate in the charger. An annual check of the tightness of the nuts and bolts is necessary to ensure the correct operation of the charger.

! It is essential that you disconnect the battery charger before disconnecting the battery terminals for maintenance (either by disconnecting the AC shore power socket or by cutting the AC circuit breaker of the battery charger).

DIAGRAM OF LAYOUT - BATTERY CABLES

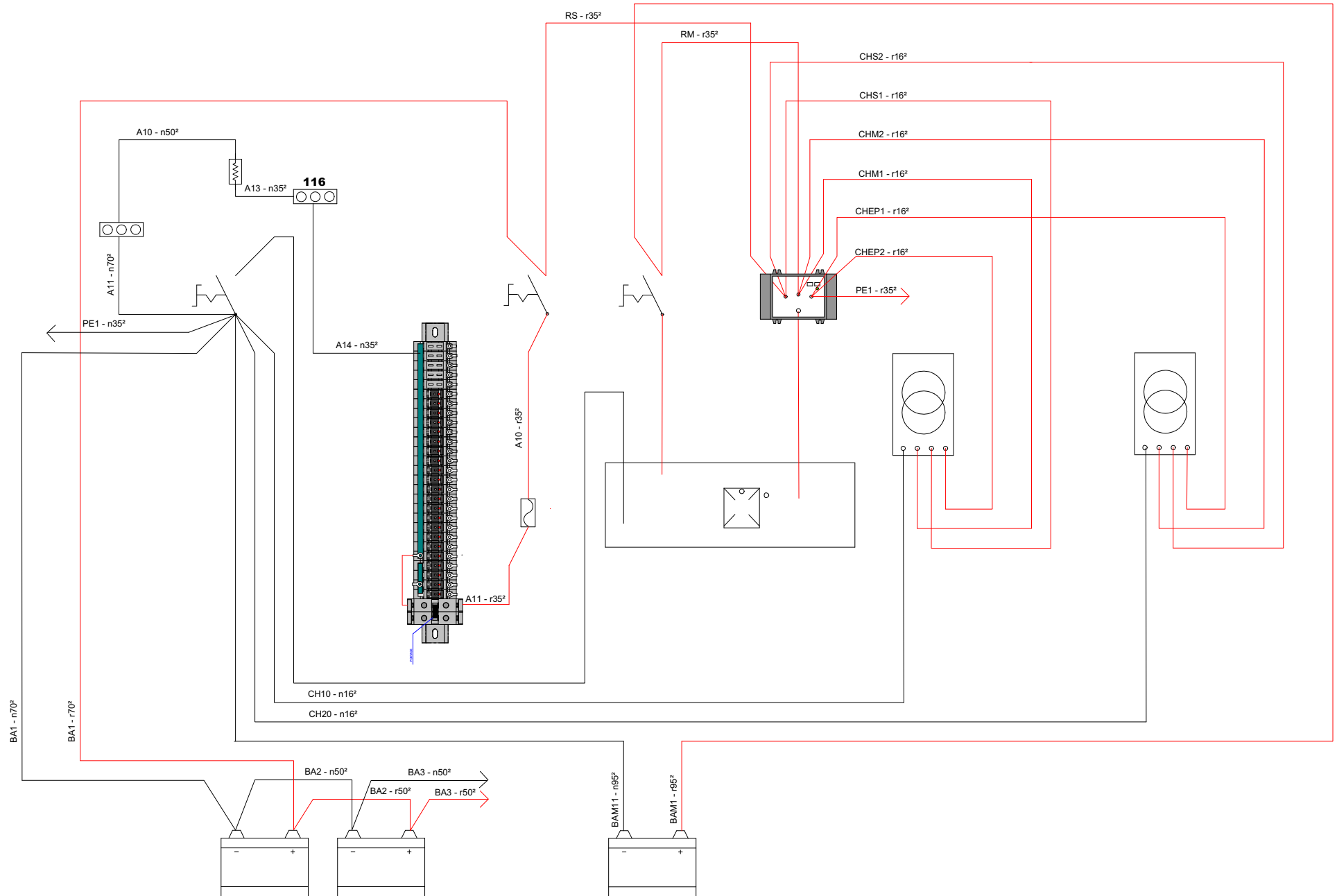
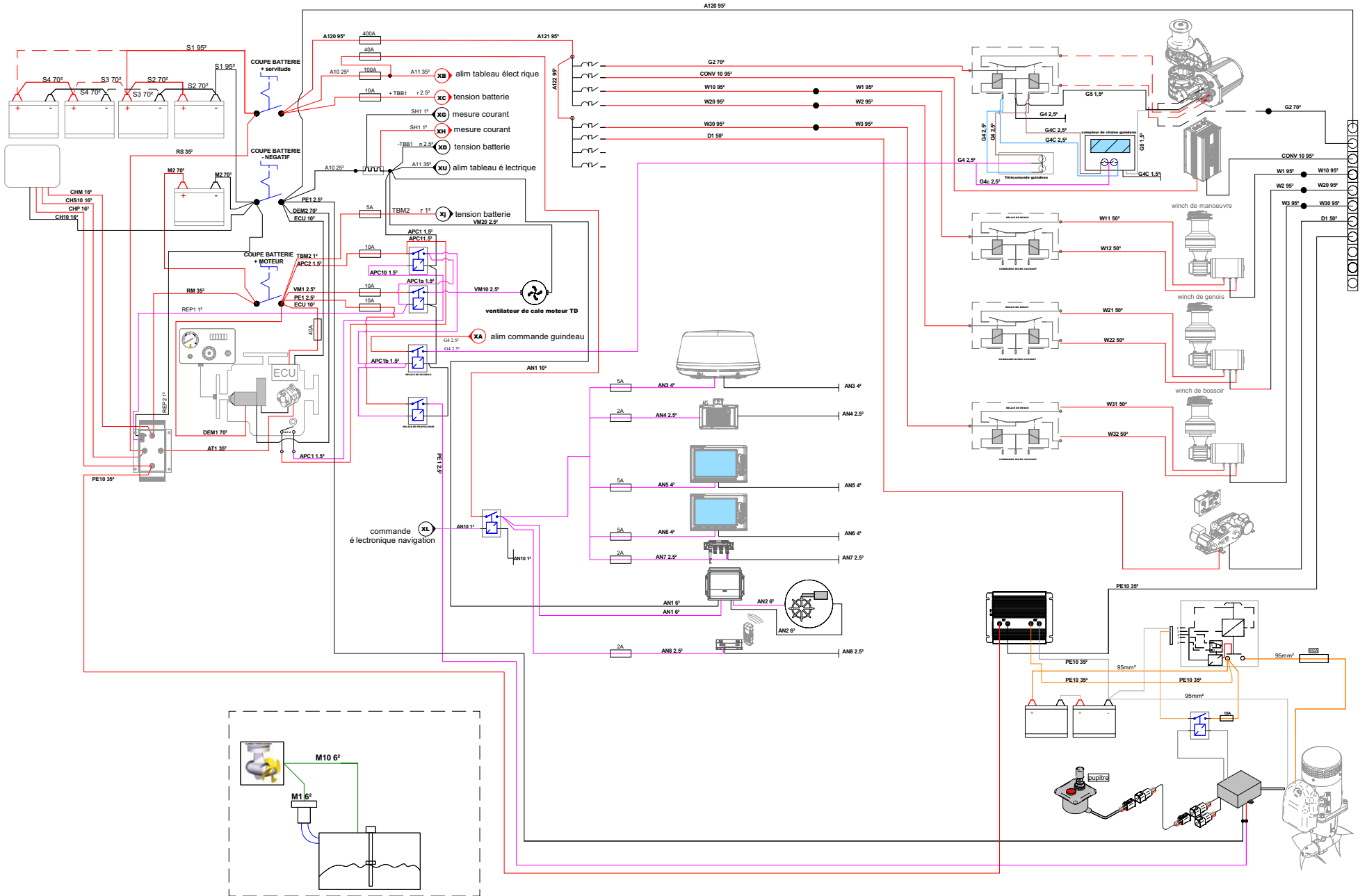
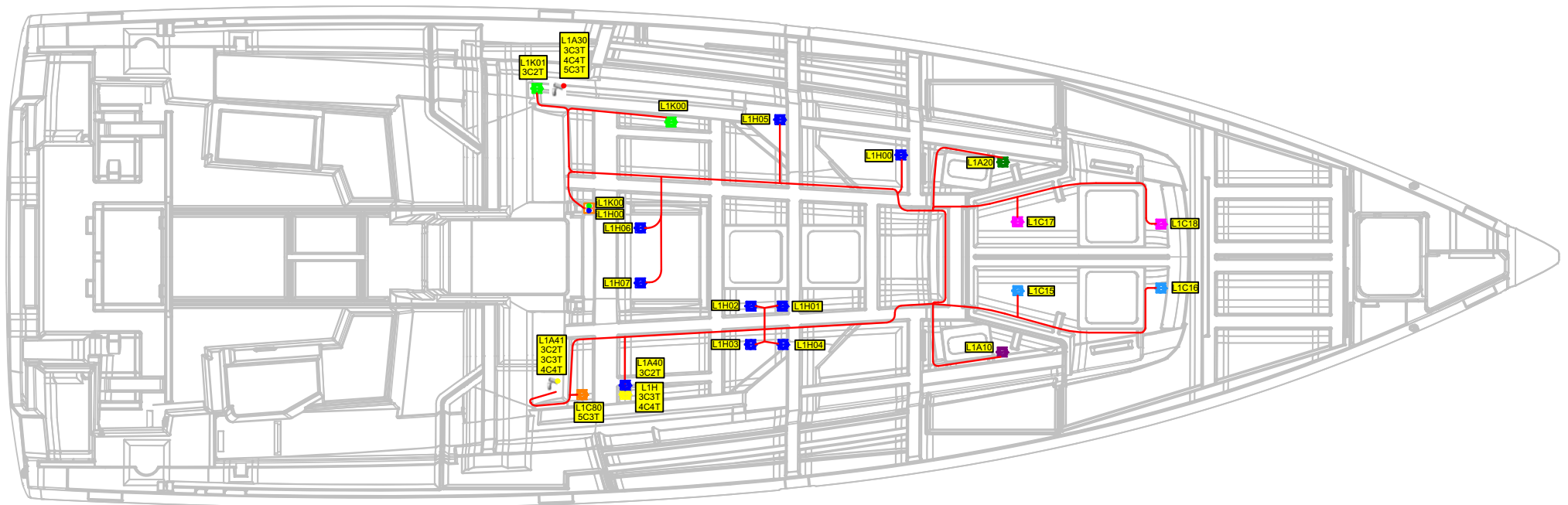

DIAGRAM OF LAYOUT - DC GENERAL CIRCUIT



8.2.6 Layout of deck wiring looms - DC circuit



8.2.7 Electrical panel

Location: Cockpit table



1. Lighting - Cockpit table
2. Lighting - Night lamps
3. Control for raising platform
4. Control for lowering platform
5. Lighting - Cockpit

Location: Chart table

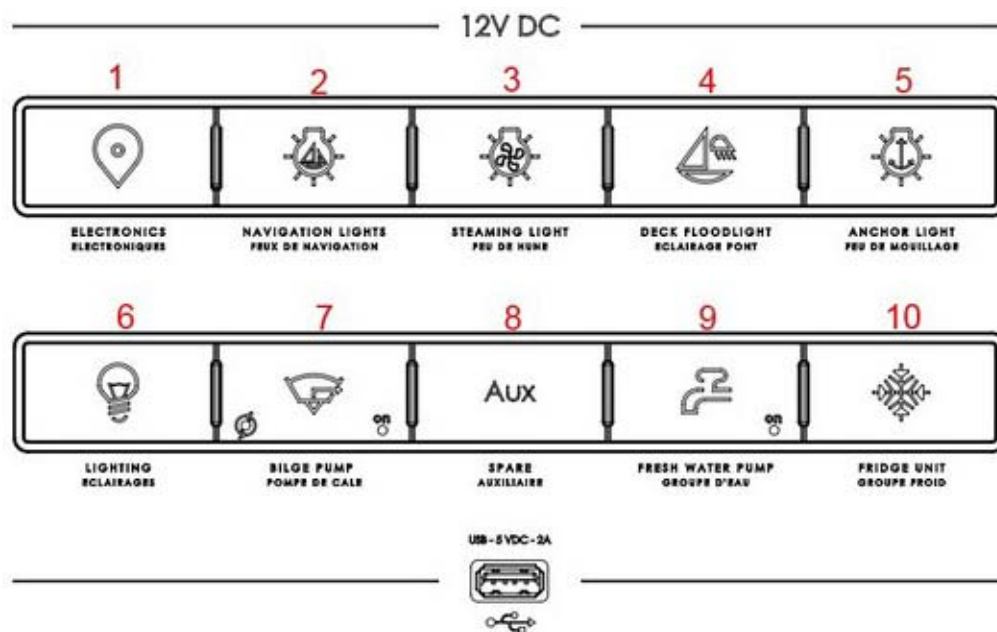

NOTE: The 10 silicone keys switch on the desired DC elements via relays.



1. Electronic instruments
2. Navigation lights
3. Steaming light
4. Deck light
5. Mooring light
6. Lighting
7. Bilge pump
8. Available
9. Water unit
10. Fridge

- When one of the switches on the panel is flashing, it means that the circuit breaker behind the electrical panel of the faulty switch must be reset.
- A fuse protects the circuit of each DC component. An additional fuse holder allows the desired element to be supplied directly by shunting the relay.

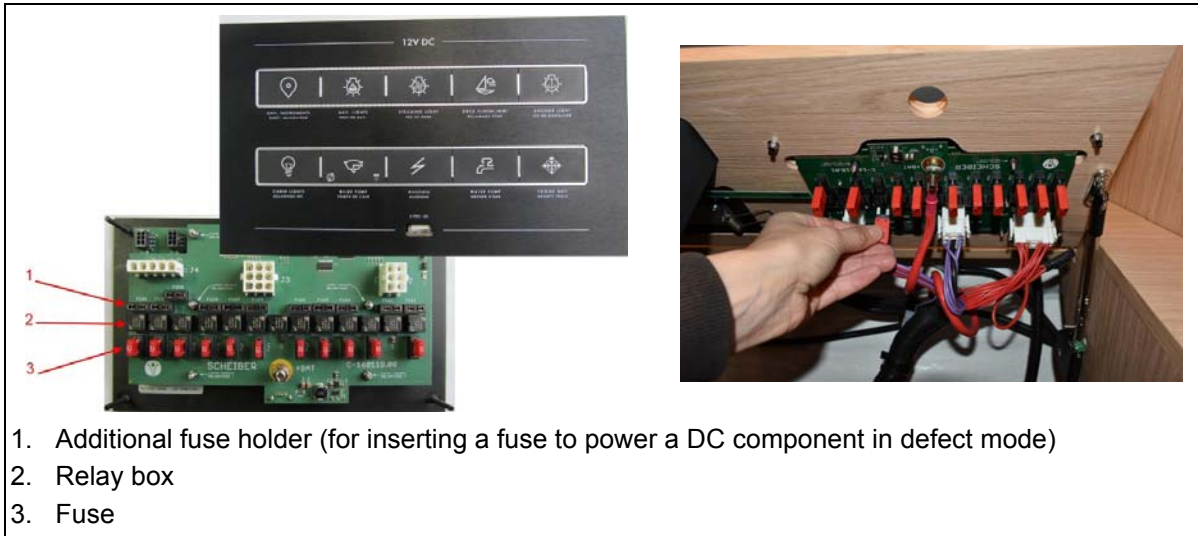

Designation	Safety fuse	Fuse in defect mode (by-pass)
Water unit	FU 3	FU 23
Electric bilge pump	FU 2	FU 22
Auxiliary	FU 4	FU 24
Refrigeration unit	FU 1	FU 21
Navigation lights	FU 8	FU 21
Steaming light	FU 9	FU 29
Mooring light	FU 7	FU 27
Electronic instruments	FU 5	FU 25
Deck light	FU 6	FU 26
Lighting 1	FU11	FU 31
Lighting 2	FU 10	FU 30

8.2.8 Circuit breakers

A circuit-breaker can be reset (manually press the black button to restart it).



Location: Starboard saloon

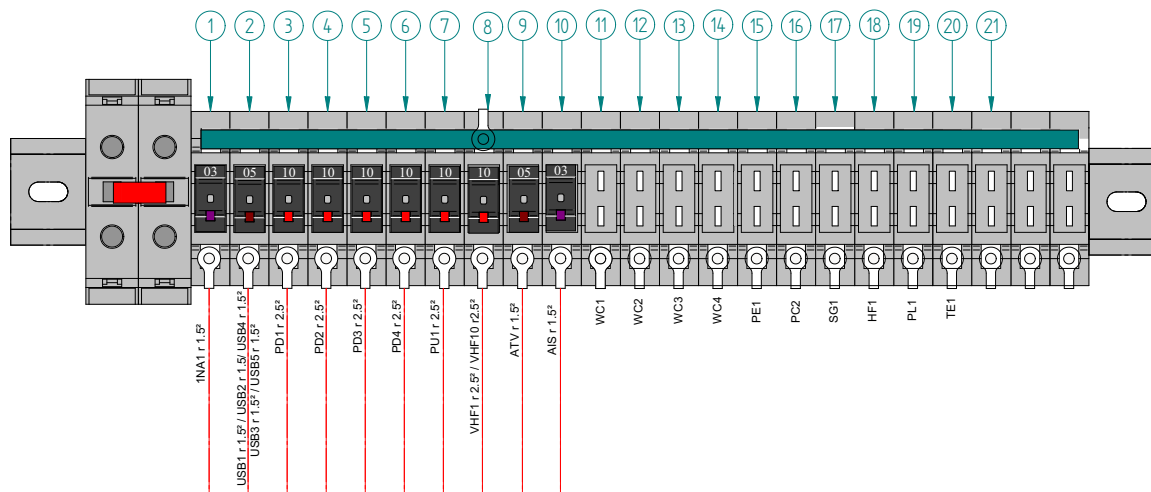

1. Electronics
2. USB socket
3. Shower pump drainage
4. Shower pump drainage
5. Shower pump drainage
6. Shower pump drainage
7. Icebox drain pump

8. VHF
9. TV
10. AIS
11. Electric toilet
12. Electric toilet
13. Electric toilet
14. Electric toilet

15. Cool box drain pump
16. Electric bilge pump
17. Gas solenoid (US Version)
18. HiFi
19. Deck wash pump
20. Mechanism for raising/lowering the TV
21. Available

Location: Starboard aft cabin



1. Electric windlass
2. Electric winch
3. Electrical aft apron

Location: Starboard saloon

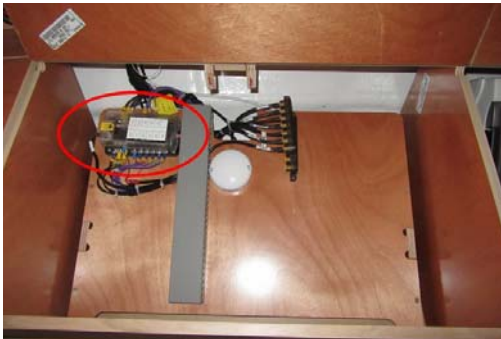

1. Electronic sensor
2. Radar
3. Screen (Starboard cockpit)
4. Screen (Port cockpit)
5. System (Deck)
6. Bridge
7. HUB

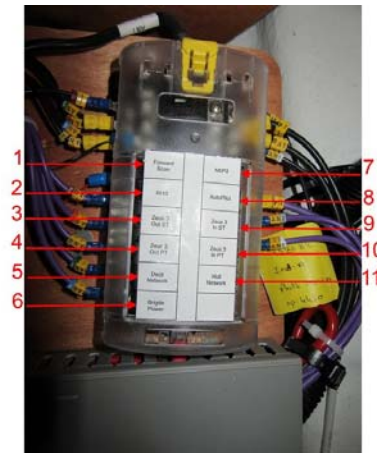

8. Autopilot
9. Screen (Interior - Starboard)
10. Screen (Interior - Port)
11. System (Hull)

8.2.9 Fuses

- A fuse protects an electrical circuit from excess current. If it blows, you must replace it with another fuse of the same rating.

General fuse for DC system

Location: Starboard aft cabin



 When replacing fuses/circuit-breakers, always ensure replacements are of the correct capacity (see the colour-codes)

20A	15A	10A	5A	3A
-----	-----	-----	----	----

8.3 TOUCH SCREEN

The touch screen allows the boat's auxiliary functions to be driven and displayed:

- Battery voltage,
- Fresh water gauge.
- Management of boat's AC supply sources.

Location: Starboard saloon



- The touch screen can be removed for maintenance by a slight manual pressure which removes it from its support.



DESCRIPTION OF ELEMENTS

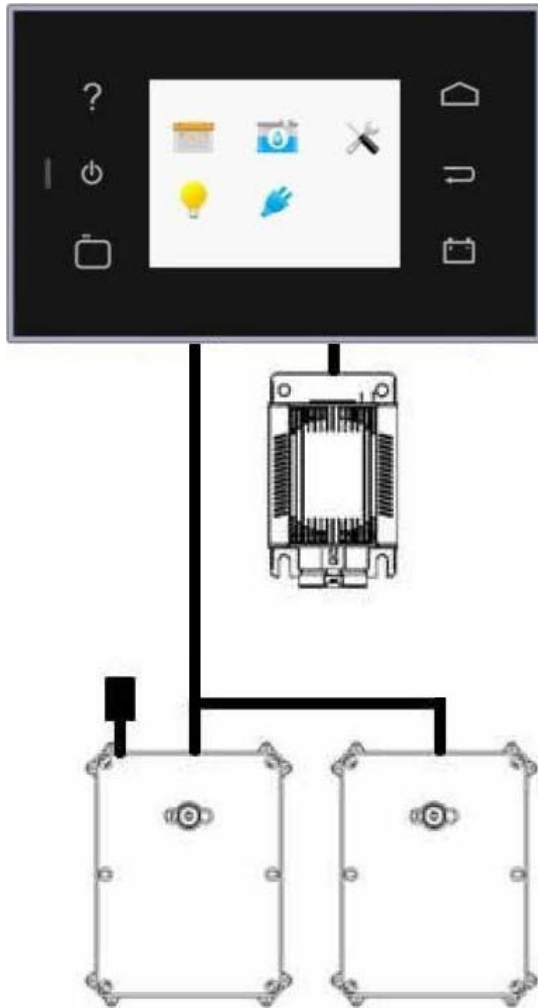

The touch screen is a device which acts on the on board auxiliary electrical circuit. It also acts on the selectors of AC sources allowing the choice of the origin of the current : shore or generator. This screen is connected to the different devices via a CAN network.

The measuring unit is a measuring interface which allows viewing of the gauges, loads (and discharges) and the voltage of the engine, auxiliaries and service batteries.

The shore / generator AC switch is used to select the AC source to operate the on board appliances. This switch is controlled by the touch screen.

Bus terminal, on final element.

LAYOUT OF COMPONENTS

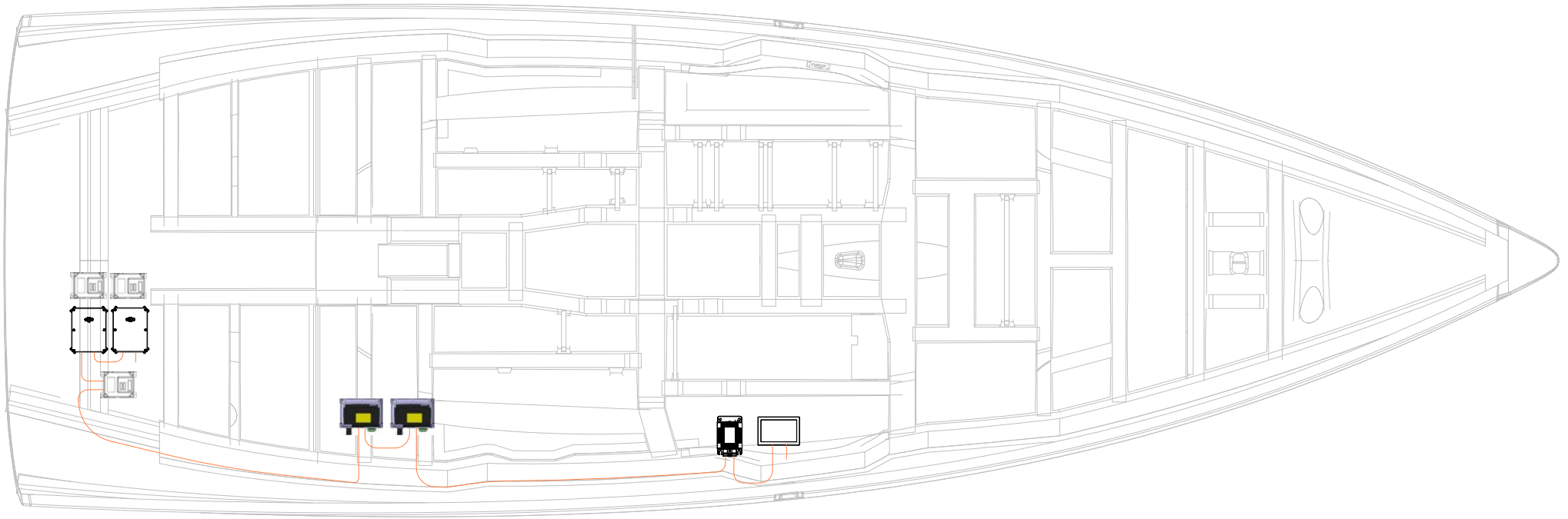
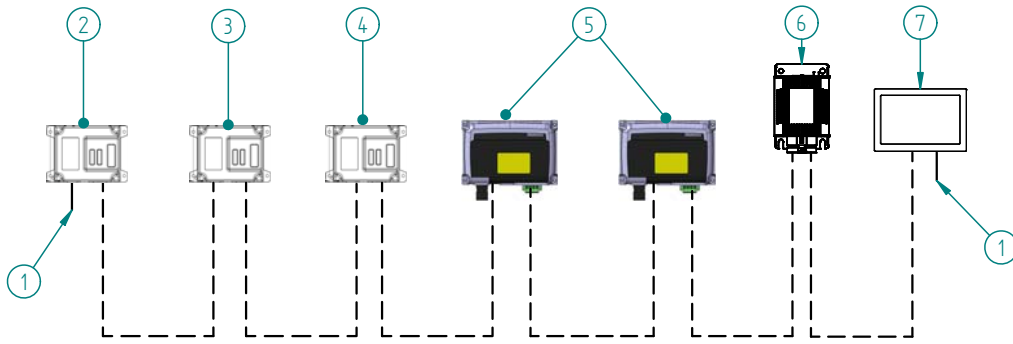
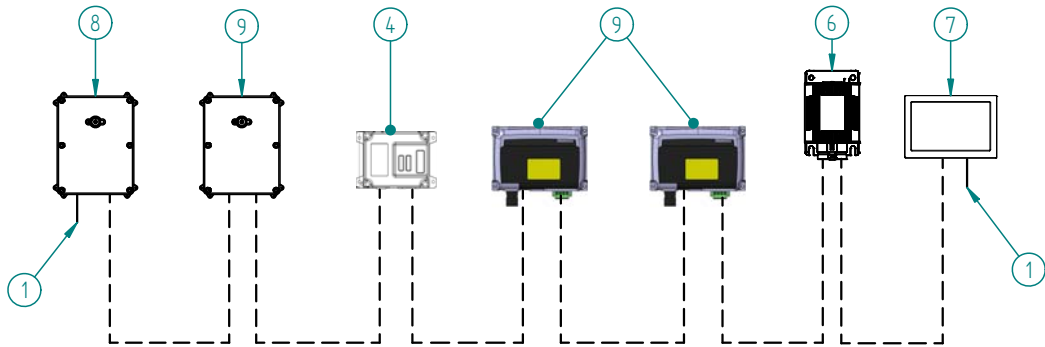

DIAGRAM OF LAYOUT

Version without generator



Version with generator



Reference	Designation
1	Terminal
2	"Measurement" box (Air conditioning)
3	"Measurement" box (DC general circuit)
4	"Measurement" box (DC/AC converter)
5	Battery chargers
6	Input block
7	Touch screen
8	Source selector (Air conditioning)
9	Source selector (Generator)

TOUCH SCREEN OPERATION

Front view:

1. Direct access to home page
2. Previous page
3. ON/OFF button
4. Tank menu
5. Back
6. Light sensor
7. Next page
8. Direct access to battery page



Rear view:

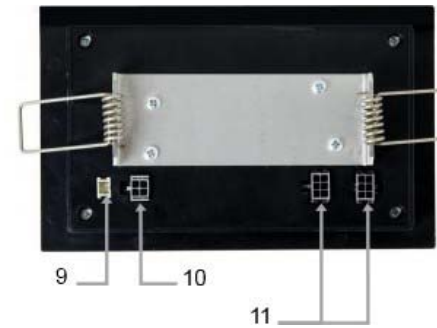

9. Connector for temperature sensor
10. Bus
11. CAN connector



Battery measurement menu access



Fresh water tank level menu access



AC supply distribution menu access

Adjustment menu access (Access to it is restricted by a code supplied on request to the yard)



- CAN network display (Controller Area Network)
- Parameterization of lighting
- Configuration of the 'gauge' pack
- Configuration of source selectors



Return to preceding page

Operation

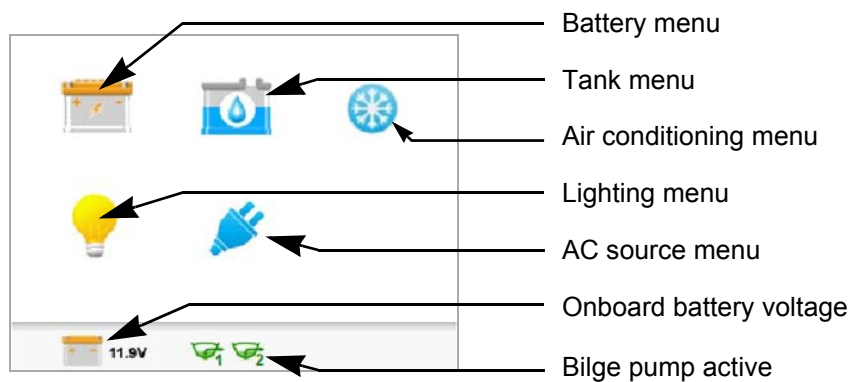

The menu may vary depending on the specific equipment of each boat.

Battery menu



Access sub-menus by pressing the required menu icon.

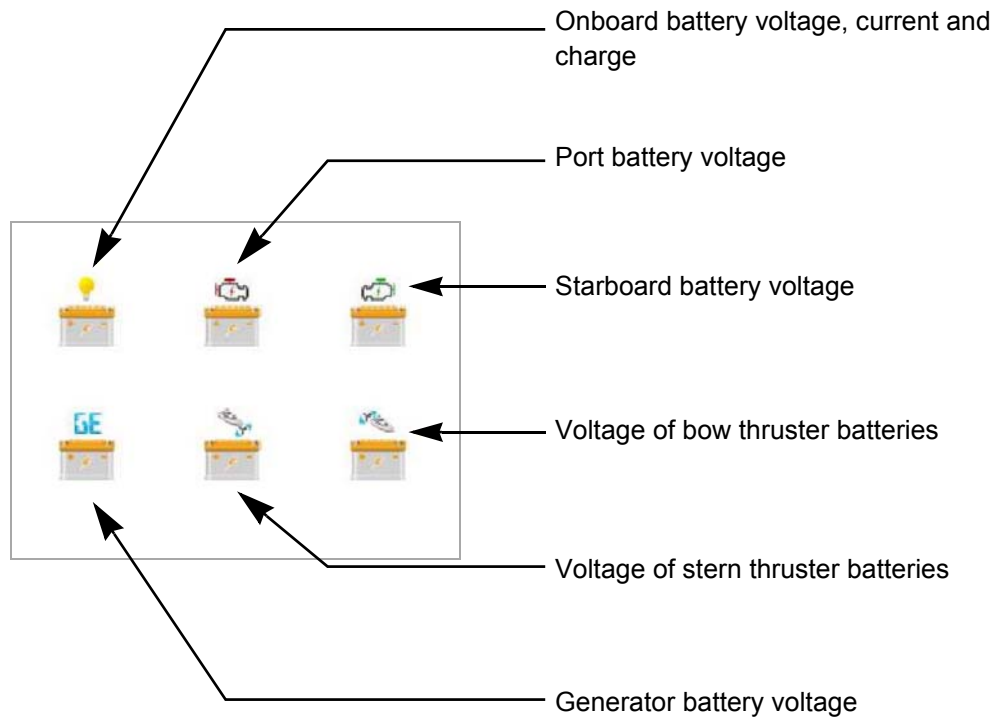

examples:

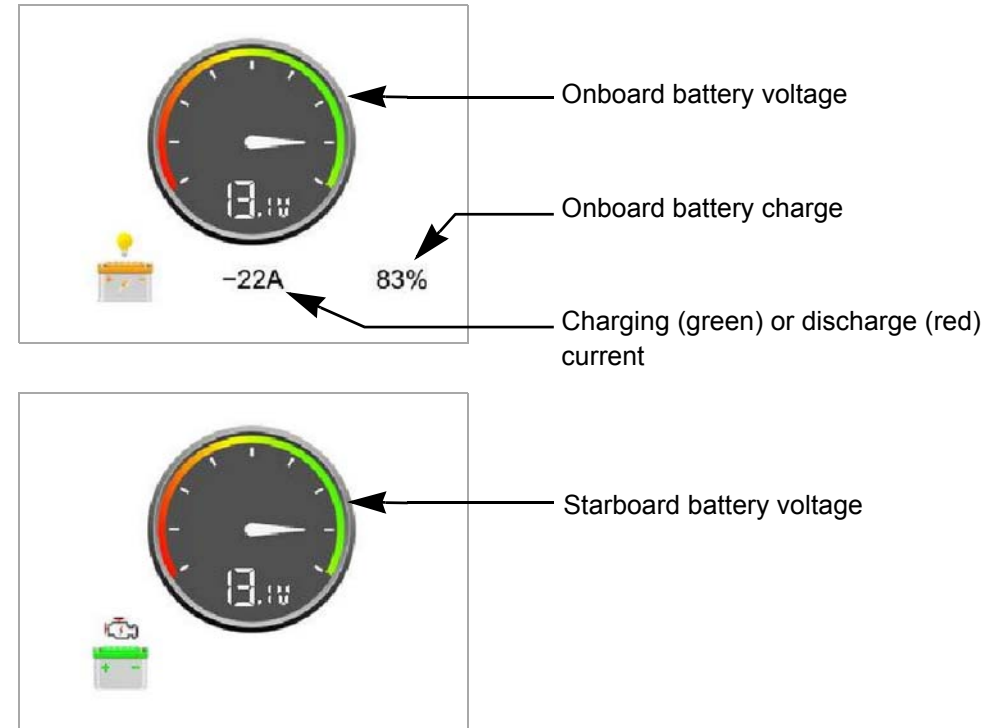

Tank menu

 Access sub-menus by pressing the required menu icon.

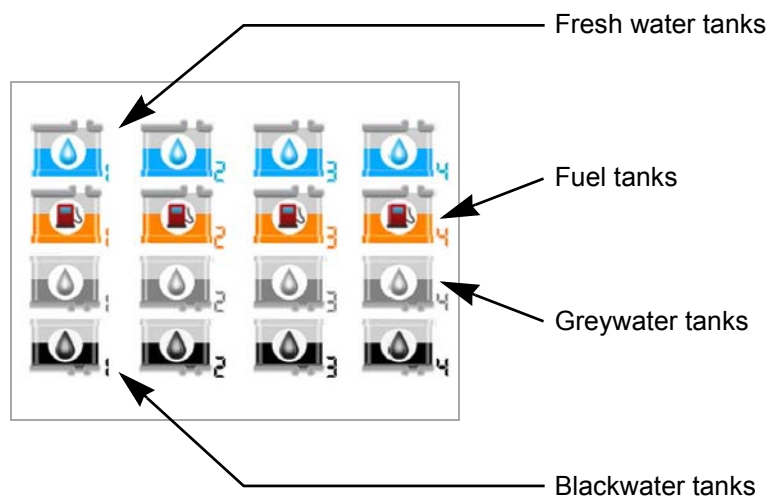

examples:

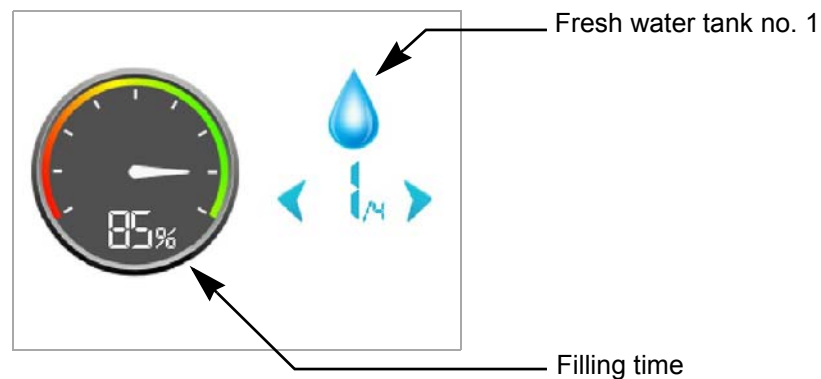

Air conditioning menu

The Navicolor controls the air conditioning in the saloon.

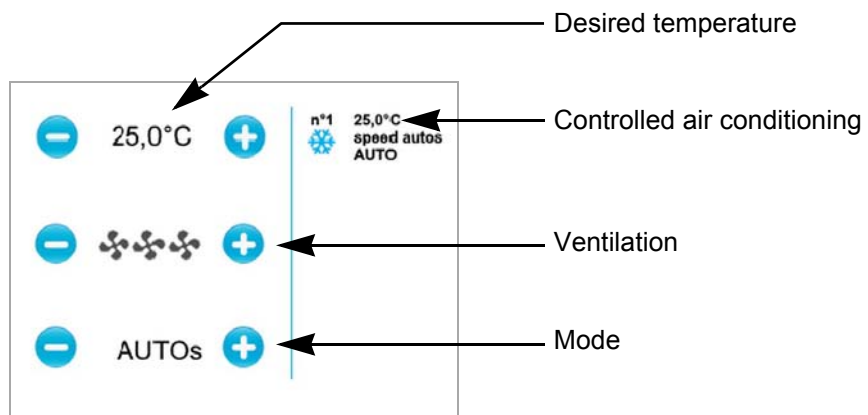

AC source menu



Access sub-menus by pressing the required menu icon.

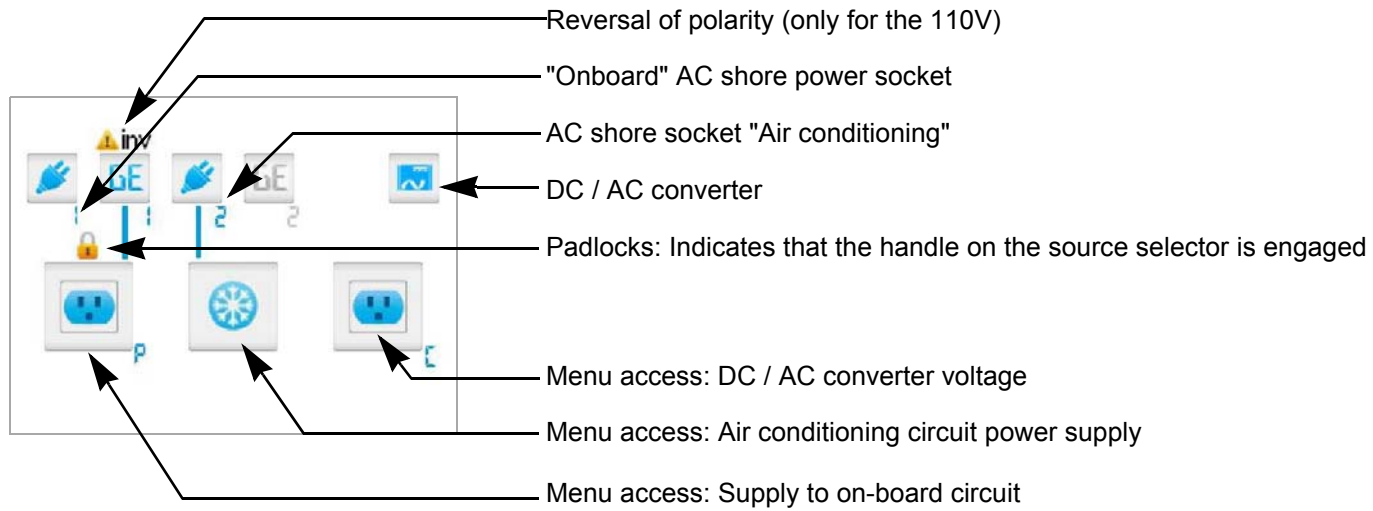

AC source menu

One press of the shore supply button sets the onboard selector switch to shore supply or generator. An orange circle indicates that the switch has been made.

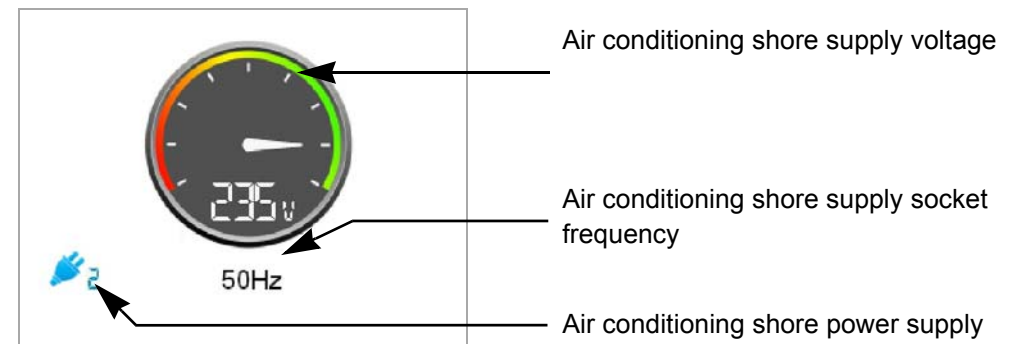
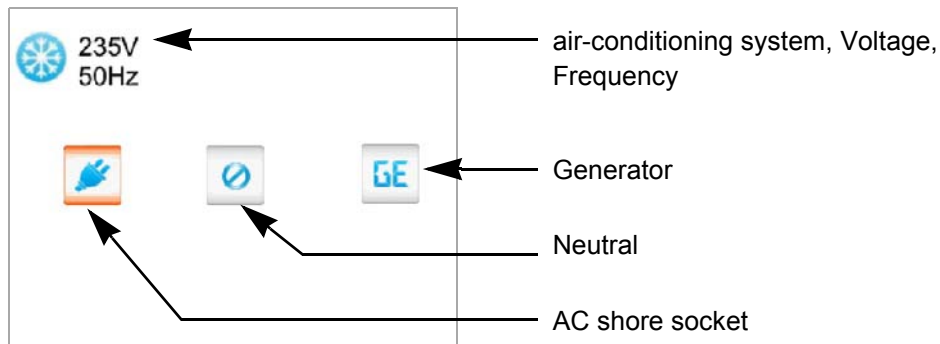
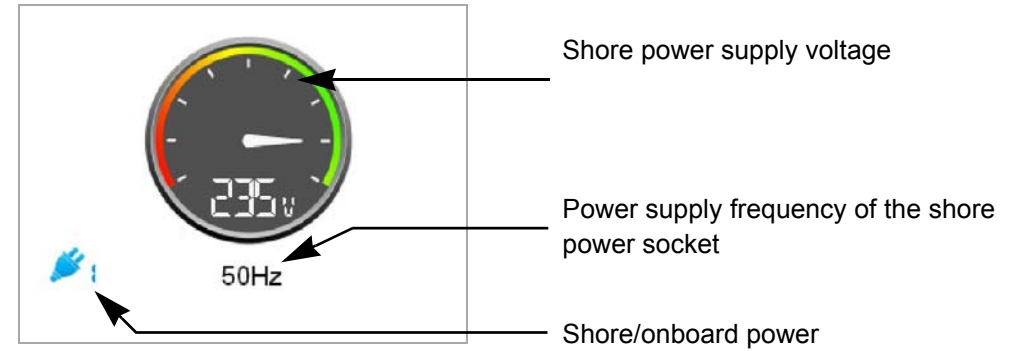
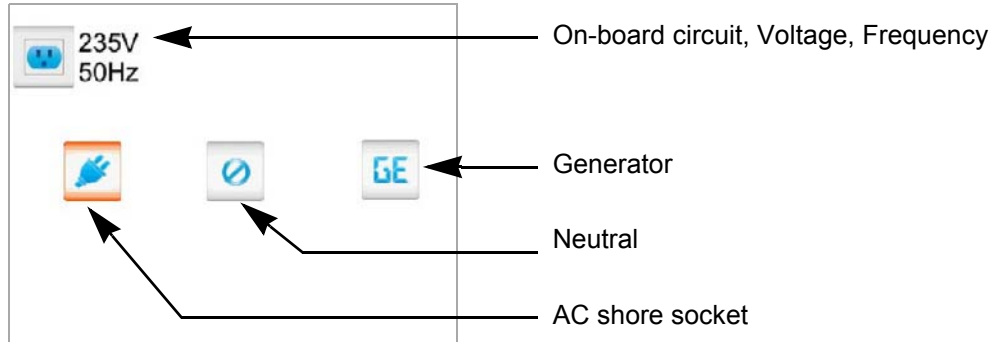

AC source menu

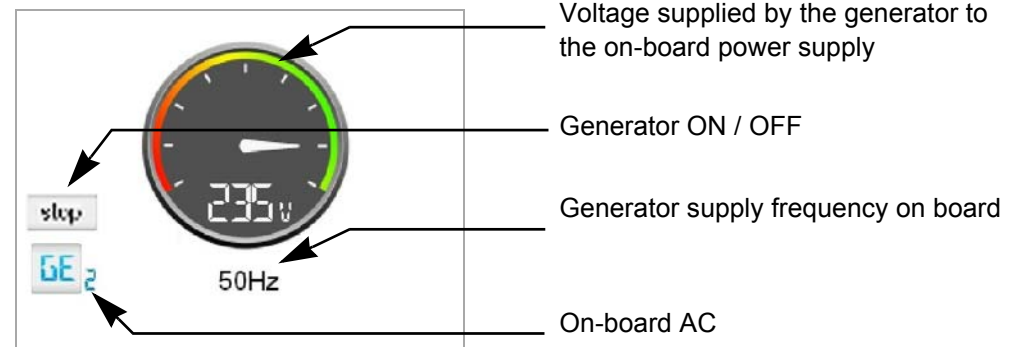
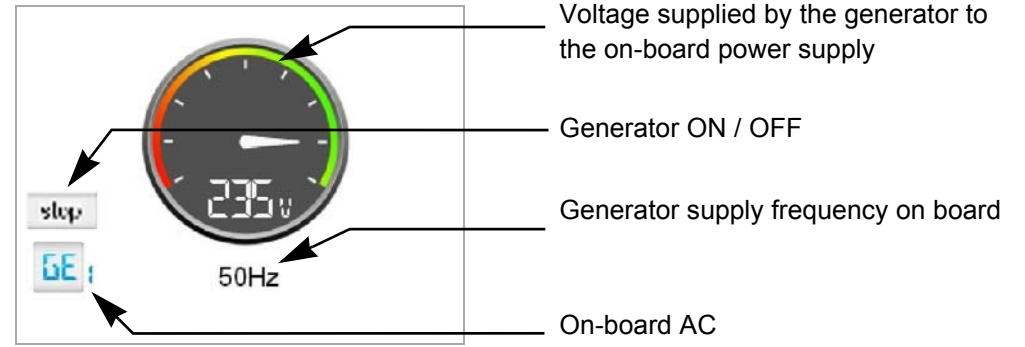
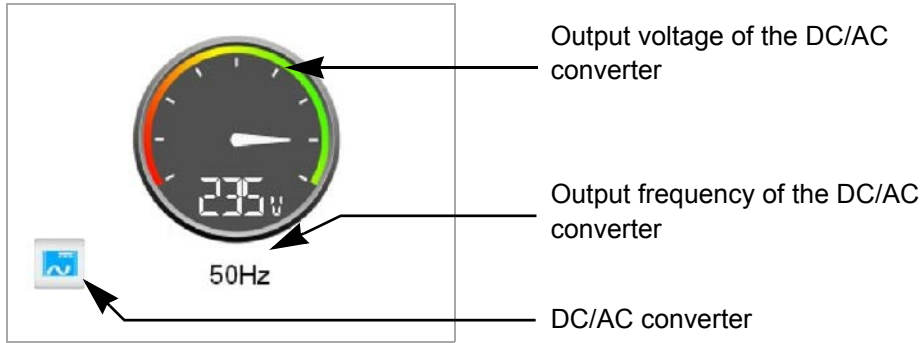

8.4 AC SYSTEM (110V OR 220V)

8.4.1 General points

- The boat is equipped with an alternating current electrical system.
- The electrical system of the boat consists of an AC shore socket and if appropriate:
 - 1 Generator,
 - 1 DC/AC converter.
- The AC electrical system is used to power the following components (where installed):
 - Air conditioning,
 - Household appliances,
 - Water heater,
 - Interior AC sockets,
 - Battery charger(s).

Guidelines for using the AC electrical system correctly

- Do not modify the vessel's electrical installations or the relevant diagrams. Installation, maintenance and modifications must be carried out by an electrician qualified in marine electricity. Have all electrical installations checked (tightening and connections) every year.
- Disconnect the boat's shore power when the system is not in use.
- Connect the relay boxes or metal casings of the installed electrical equipment to the boat's protective conductor (green or green with yellow stripe).
- Use double-insulated or earthed appliances.
- If the reverse polarity indicator is activated, do not use the electrical installation. Rectify the polarity fault before using the vessel's electrical installation (this applies only to polarised circuits with a polarity indicator).

 **If a DC/AC converter is fitted on board: it is essential to switch off the DC and AC circuits before working on the cabin AC sockets.**

- 
- Never let the end of the boat/shore supply cable hang in the water: This may result in an electric field that could injure or kill nearby swimmers.
 - Incorrect use of alternating current systems will result in a danger of electrocution.
 - Do not work on a live AC system.

 To reduce the risk of electric shock and fire:

- Turn off the shore supply with the onboard cut-off switch before connecting or disconnecting the vessel/shore supply line.
- Connect the boat/shore power cable on the boat before plugging it into the socket onshore.
- Disconnect the boat/shore power cable at the shore socket first.
- If the reverse polarity indicator is activated immediately disconnect the cable.
- After using the socket onshore, close its protective cover tightly.
- Do not modify the connections of the boat/shore power cable: only use compatible connections.

DO NOT MODIFY THE CONNECTIONS OF THE BOAT/SHORE POWER CABLE.

 Electrical connections change over time. It is necessary to have the boat's electrics checked regularly and at least once every two years by a professional. Special attention should be paid to the tightness of the electrical connections.

 Every month, you are advised to test the circuit breaker or residual current differential switch, recognisable by its "test" button.

8.4.2 AC shore socket

Location of components

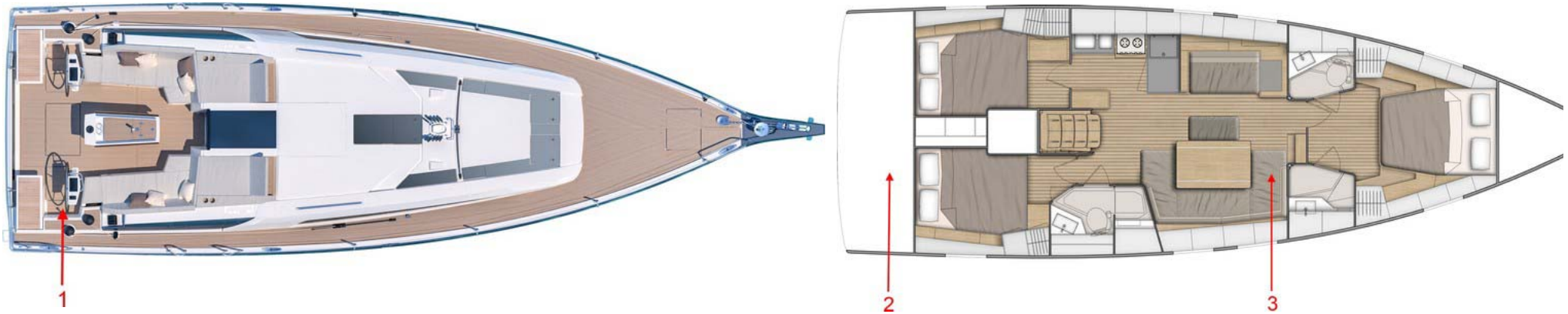

Ref 1: AC shore socket



Ref 2: Bipolar circuit breaker (Protection)



Ref 3: Differential switch (Operation)



Operation

- First plug the extension cable into the AC socket on the boat, then into the socket onshore.
- First unplug the extension cable from the socket onshore, then from the AC socket on the boat.

Control

- The winder is unwound manually.
- The winder is wound electrically.

Electric furler - Shore power socket
(US Version)



 Refer to the manufacturer's instructions for use and maintenance.

8.4.3 AC source selectors

The shore-generator switch is the actuator for:

- switching between the different AC sources available on the boat. These include the dock socket(s) and the generator.
- measuring the voltage, frequency and current of the power sources connected to it.
- generator start (selector no°1 "onboard") or air conditioning (selector no°2 "air conditioning").
- an isolated measurement (galvanic) of the generator battery.

In the event of system failure, the switch can be operated manually using the handle on the device. Engage the handle, then switch to the right or left of the device to select the desired AC source.

Maintaining switching positions does not require power consumption.

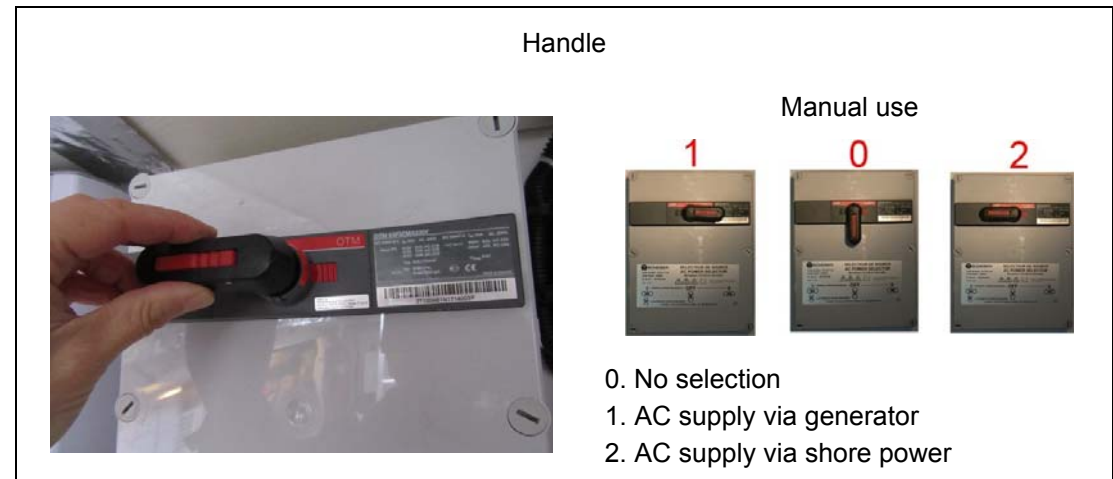
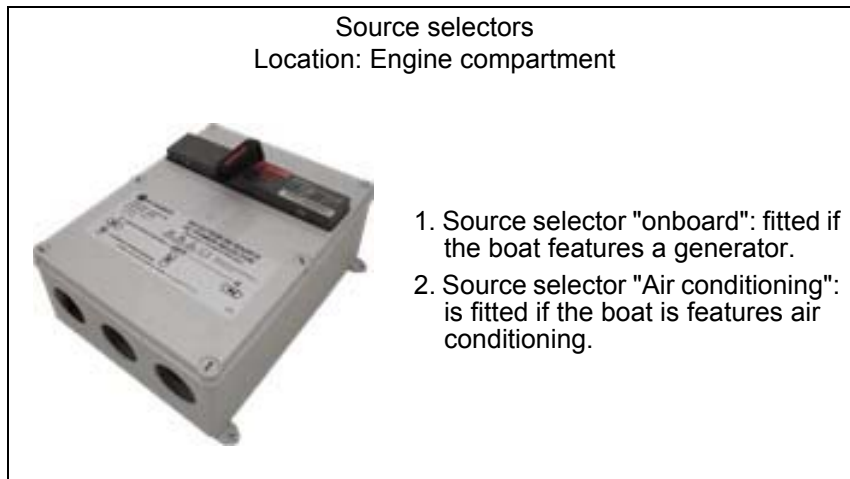

Operation

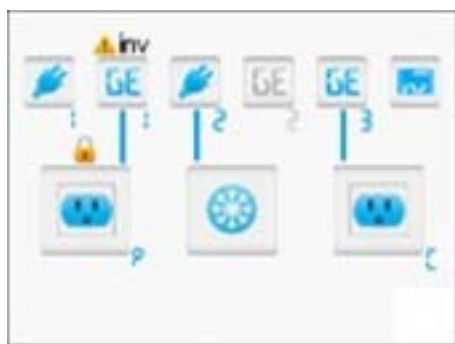
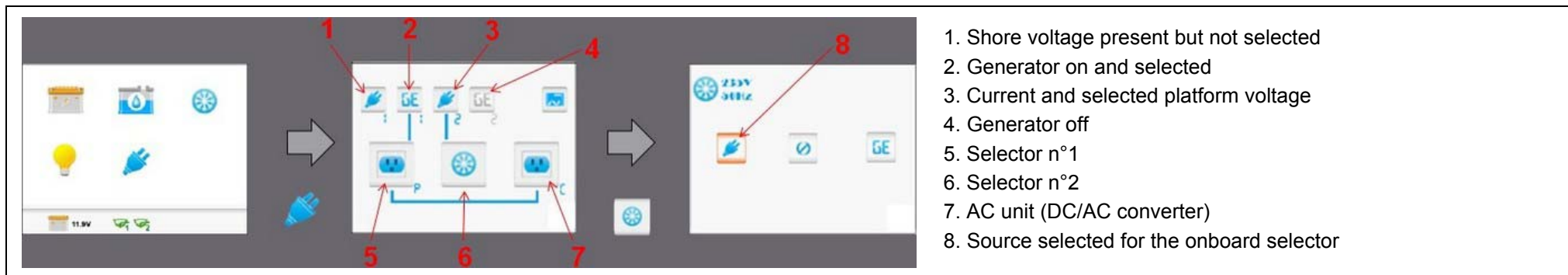

Here, on selector n°1, the padlock indicates the presence of the manual control handle on the selector. Switching cannot be carried out through the screen.

8.4.4 Diagram of layout

Europe Version (220V / 50Hz)

AC ELECTRICAL SYSTEM

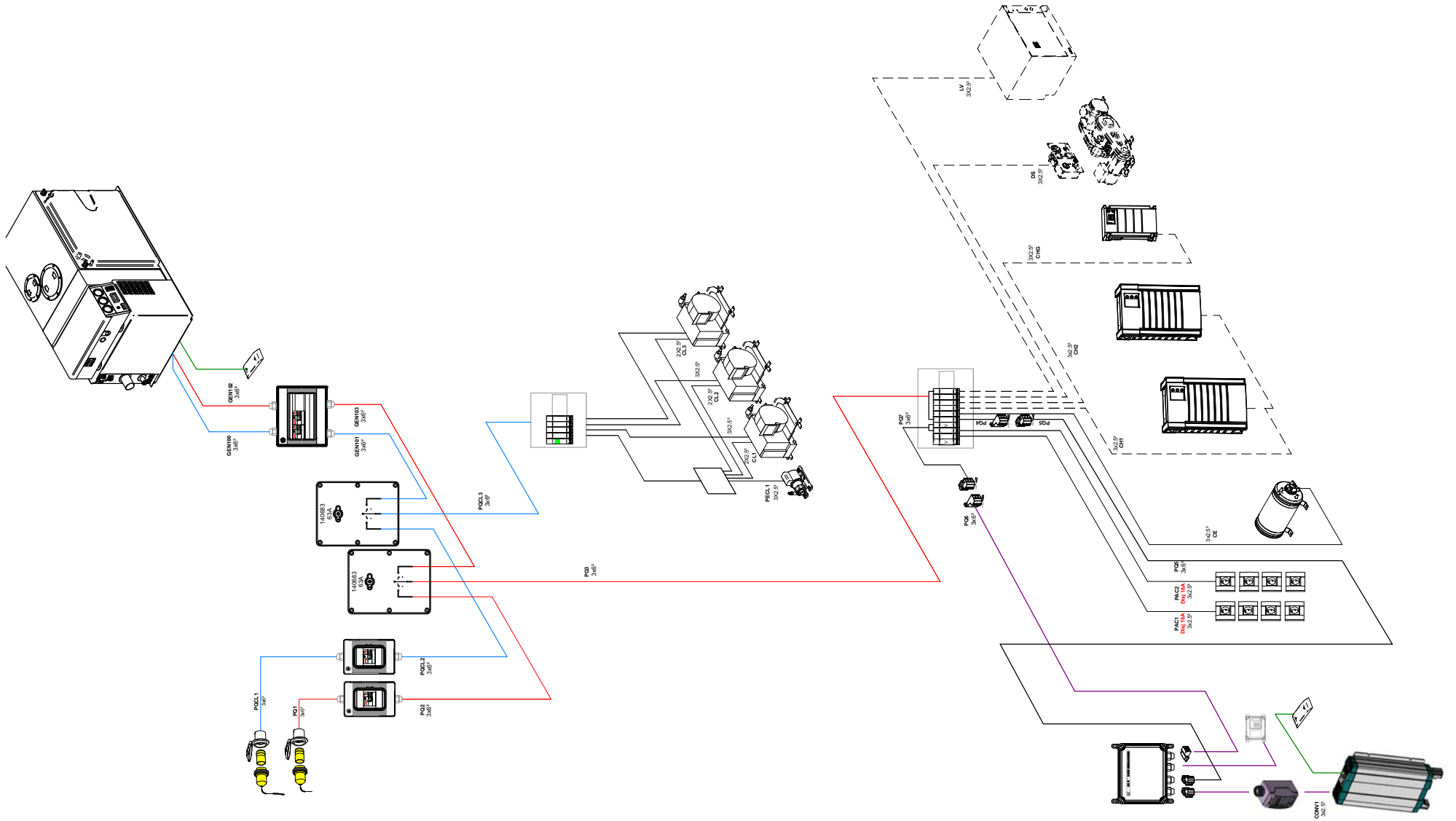

8.4.5 DC/AC converter

Description

- The inverter converts the DC voltage of the service battery bank to AC voltage. The circuit between the inverter and the batteries is protected by a fuse or a circuit-breaker.
- The inverter is earthed by an earthing plate located under the hull (see Chapter: EARTHING PLATES).
- The voltage measurement delivered at the converter output is visible on the touch screen.

Operation

Power supply for the 220V AC electric sockets in the cabins:

Once there is sufficient nominal voltage coming from the AC switch panel, AC power is supplied by the onshore socket or by the generator.

If there is insufficient nominal voltage coming from the AC switch panel, the AC power supply automatically switches over to the inverter. In this way, the power for the 220V sockets in the cabins can be supplied by the inverter, itself supplied by the service battery bank. Be careful to disconnect the inverter circuit to prevent the AC power supply automatically switching over and to prevent accidental discharge of the service battery bank. This can be done by:

- setting the inverter's circuit-breaker to the OFF position; or,
- setting the switch located on the inverter to the OFF position.

Simply cutting the AC power supply at the switch panel does not cut the AC power supply to the cabins: it is also necessary to disconnect the DC supply.

Operation

- The inverter is fully automatic.
- A remote control is located near the boat's switch panel. To start the converter put the switch on the inverter in the "REMOTE" position then put the switch located on the remote control in the "ON" position.
- If the switch on the inverter is in the "OFF" position, you cannot use the remote control to start it.

- The DC/AC converter operates by default when shore power is not supplied. It is controlled by a relay connected to the shore power supply. This converter powers the indoor sockets and some onboard appliances.
- When shore power is not connected, the relay automatically connects the inverter to a part of the onboard AC circuit.
- When the shore power socket is plugged in and powered, the relay automatically disconnects the inverter.

Location: Cockpit locker



1. DC/AC converter
2. Breaker
3. Relay box

200A breaker
Location: Port aft cabin



Maintenance

- Check at least once a year that the inverter cables and connections are securely tightened.
- Clean the inverter by removing any accumulated dust to ensure good ventilation.

Control located on the equipment



Remote control
Location: Port aft cabin



- ! - Refer to the manufacturer's instructions for use and maintenance.
- NEVER:
 - connect the inverter AC lead to an AC terminal or to the onboard generator.
 - disconnect the wiring from the inverter when in use.
 - open the inverter.

8.4.6 AC breakers

Location: Starboard saloon

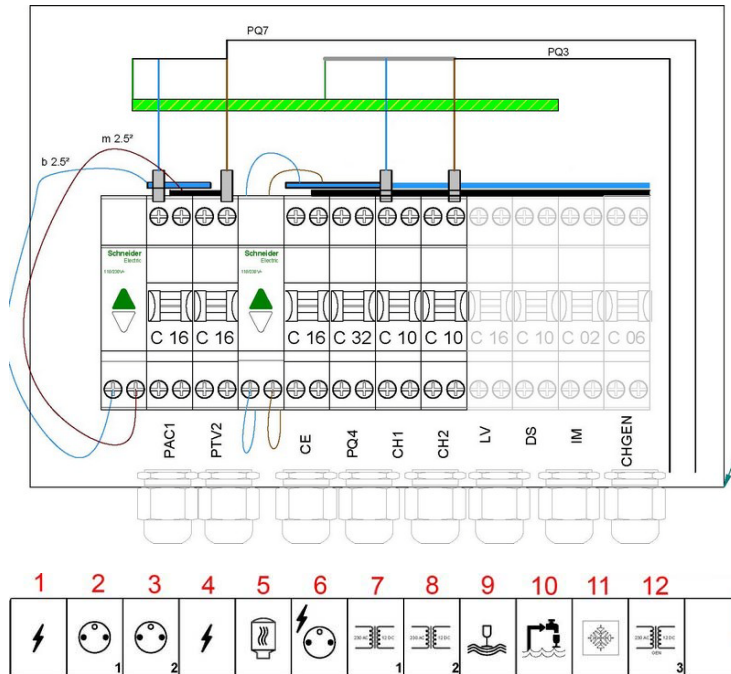

1. Mains power (Interior AC socket circuit)
2. Interior AC socket
3. Interior AC socket
4. Mains power (AC elements)
5. Water heater
6. DC/AC converter
7. Battery charger
8. Battery charger
9. Dishwasher
10. Watermaker
11. Ice maker
12. Generator battery charger

8.4.7 Hull wiring looms - AC circuit

GENERAL

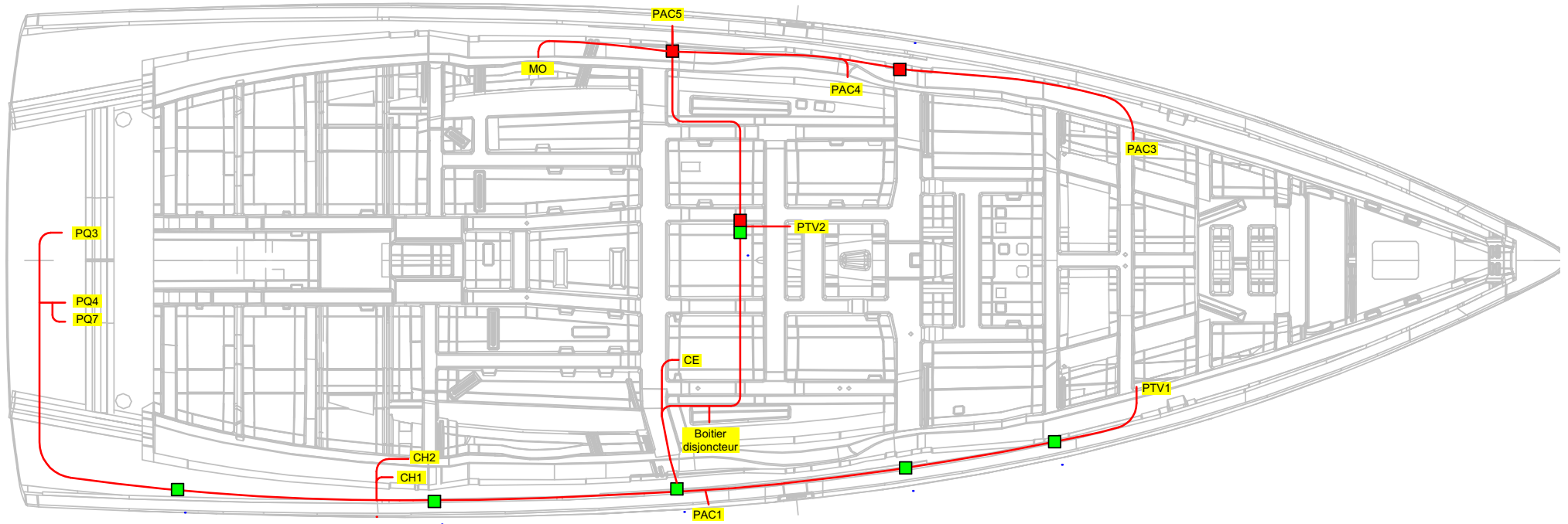

AIR CONDITIONING

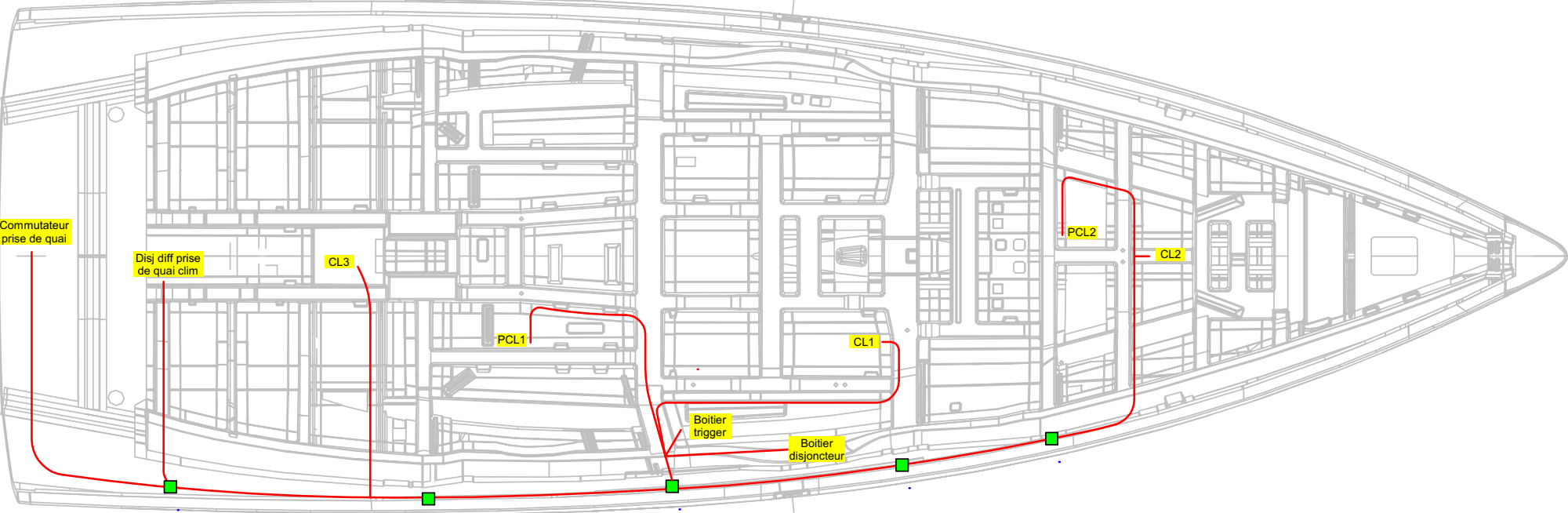

8.5 PROTECTION AGAINST ELECTROLYSIS / EARTH PLATE

8.5.1 Anodes

General points

- The sacrificial anode protects the submerged elements of the boat against electrolysis.
- A sacrificial anode is a consumable part that protects submerged metal parts by its dissolution (oxidation). The anodes used are made of a metal that is more readily reductive than the metal they are protecting.
- On a new boat, all the underwater metallic components seek to reach the same electric potential, which leads to the rapid deterioration of the anodes during the first few weeks in the water.
- You can put several anodes on the hull.

Maintenance

- At least 2 times a year, check the corrosion on all of the anodes. Change the anode if necessary (Before it has lost 50% of its weight).
- Use the appropriate anodes for the cruising area: magnesium anodes for fresh water; zinc anodes for seawater.
- When the boat is kept in a dry dock, a light deposit of dust will settle on the anodes: clean the anodes before relaunching.

Cleaning anodes

- Use emery paper. Do not use metal brushes or steel tools to clean the boat as this may damage the galvanic protection.



- Never cover the anodes in antifoul.
- During the first few weeks that the boat is in the water, check the anodes and replace them if necessary: they erode very rapidly during this period.

Replacing the anodes

- The anodes are fastened with screws and nuts. First, remove the screws and nuts that hold the anode, then clean the contact surface. Press the new anode to obtain a good electrical contact.
- Change all the anodes every year.

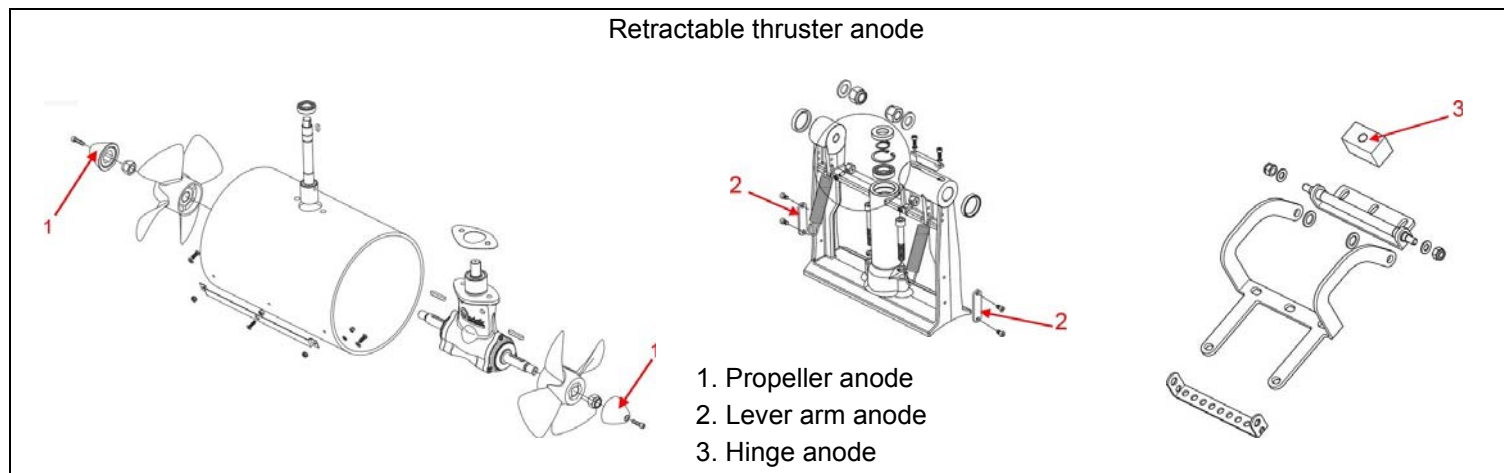

Anode plate



Thruster anode (Nozzle)



8.5.2 Earthing plates

- An earthing plate is a shot-peened plate mounted on the hull to recreate an earth neutral point on the electrical circuit of the equipment supplying AC power (generator and AC/DC converter). The earthing plate earths this equipment.

The earthing plate is not an anode: it must not be allowed to deteriorate.

- If the earthing plate deteriorates, consult a professional immediately to determine the cause. Because it is mounted across the hull below the waterline, deterioration of the earthing plate puts the boat at risk of sinking.

 Never antifoul over the earthing plates.

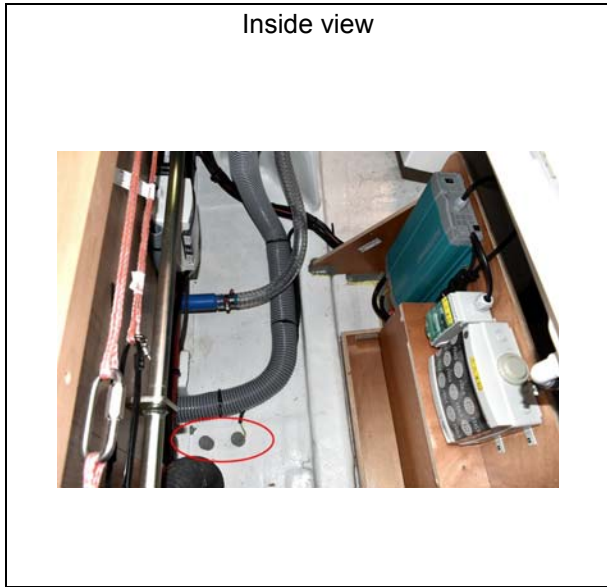
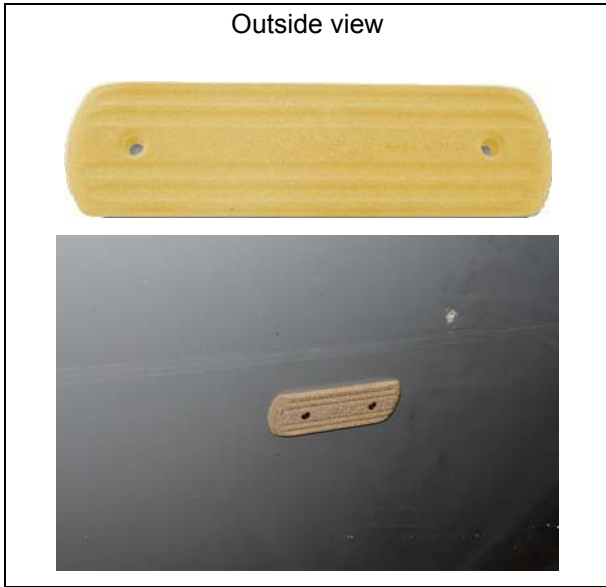

LIQUEFIED PETROLEUM GAS SYSTEM (LPG)

■ General points	120
■ Operation of the LPG system	121
■ Verification of the LPG system	121
■ Diagram of layout	123
■ Cooking appliances with built-in LPG cylinder	124

9.1 GENERAL POINTS

- The working pressure of the LPG unit is 28 millibars.
- Recommended cylinder capacity:
 - Europe Version: 2,75 kg of butane.
 - US Version: 10 lb of propane.
- Have the hoses, the entire LPG system and the flue pipes in the LPG system inspected professionally and regularly (or at intervals determined by the national requirements of the country in which the boat sails), and have them replaced if damage is detected.
- Taps attached to empty cylinders must be closed and disconnected. Protective covers, lids or caps must be held in place. Spare bottles must be stored outside on the boat and protected from weather and mechanical damage. If a gas leak occurs, it is essential that the gas escapes outside.
- Do not impede access to the components of the LPG system.
- Do not use the housings or the LPG bottle lockers to store other equipment.
- Check the vent pipes at least once a year. Replace them if they have deteriorated or split.

Location of components

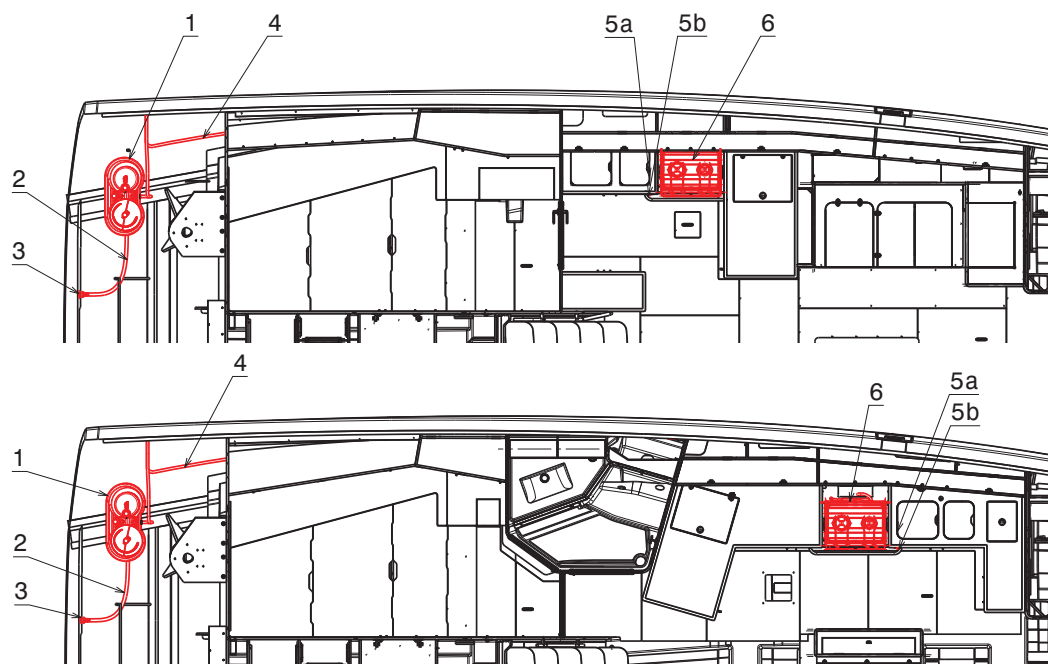

Reference	Designation
1	Gas cylinder locker
2	Drain
3	Kitchen sink thru-hull drainage
4	Gas system
5	Gas supply valve (Europe Version)
5b	Solenoid (US Version)
6	Hob / Oven

9.2 OPERATION OF THE LPG SYSTEM

- Valves for supply lines and cylinder valves must be closed when appliances are not in use, before changing a cylinder and immediately in case of emergency.
- Appliance valves must be closed before opening the cylinder valve.
- Ventilation is necessary when appliances that consume oxygen from inside the boat are used.
- If the stove is not suspended by gimbals, it should not be used when wide roll angles or continuous listing are likely.
- Please refer to the manufacturer's notes for the use and maintenance of the LPG cooker.

9.3 VERIFICATION OF THE LPG SYSTEM

The LP system should be tested for leakage before each use in any of the following ways:

- If the LPG circuit is equipped with a pressure gauge:

Before each use, close the appliance valve, open the LPG cylinder valve, allow the pressure gauge to stabilize, close the LPG cylinder valve and observe the pressure indicated by the pressure gauge near the LPG cylinder for 3 minutes. The pressure indicated by the manometer should be constant if there is no leak in the system.

The pressure indicated by the manometer should be constant if there is no leak in the system. If bubbles are observed in the detector liquid, there is a leak.

NOTE: The pressure gauge only indicates vapour pressure, which is a constant at a given temperature. It gives no indication of the amount of LPG remaining in the cylinder..

- If the LPG circuit is equipped with a bubble leak detector, use it as follows:

Regularly observe the bubble leak detector.

OR

Once the installation is pressurised and stabilised, press the detector push button. The installation is not leaking if bubbles do not appear in the detector liquid. If bubbles are observed in the detector liquid, there is a leak.

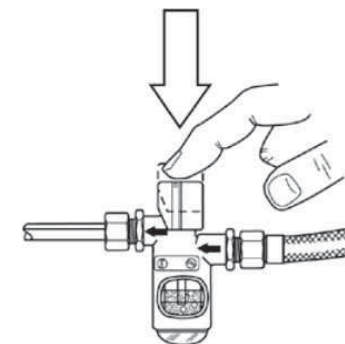

- Carry out a manual search by applying a foaming solution, soapy water or a detergent (with the burner taps closed and the installation and gas bottle taps left open). Foaming solutions for detecting leaks in gas installations conforming to EN 14291 are adequate for these requirements.

- If an LPG leak is detected or suspected, immediately take the following measures:
 - Cease use of all LPG appliances;
 - Disconnect the LPG supply from the supply valve(s);
 - Extinguish all naked flames and other sources of ignition (heaters, cooking appliances, pilot lights, etc.);
 - Do not operate electrical switches;
 - Evacuate the area if possible.

NOTE: Leak tests carried out by the boat user are not a substitute for regular and complete checks of the LPG circuit by a competent professional.

To change an LPG bottle

1. Close the tap on the LPG bottle
2. Detach the LPG bottle
3. Replace the LPG bottle
4. Attach the new LPG bottle
5. Open the tap on the LPG bottle

Gas cylinder locker



Gas supply valve



 - When the cooker is on, ventilate well to prevent any risk of asphyxiation.
- Do not use the cooker as a means of heating.

 - If a leak or fire from an LPG tank is detected, close the main LPG supply valve and do not use LPG appliances.
- Do not use an installation with a leak before it has been inspected and repaired by a competent person.
- Do not modify the boat's LPG system. Installation, modification and maintenance should be carried out by a qualified individual. Have the system checked at regular intervals or as prescribed by national requirements.
- Never use a naked flame to check for leaks.
- Do not use a hotplate or an oven to heat the living areas.
- Fuel-burning equipment with a naked flame consumes the oxygen in the cabin and leaves combustion residue in the boat. Ventilation is necessary when this equipment is used. Open the vents provided for this purpose when using this equipment. Do not use a hotplate or an oven to heat the living areas. Never obstruct the openings provided for ventilation.
- Ventilation requirements have been calculated for LPG appliances as installed. Additional ventilation openings may be required if other appliances are installed in addition to these (please consult a professional).
- Never leave the boat unsupervised when equipment using LPG with a naked flame is on.
- Do not smoke or use a naked flame when replacing LPG bottles. Close the tap on the empty bottle before detaching to replace it.
- To ensure sufficient ventilation, make sure that you open the hatches or ports near the hotplate when using it.

 - Do not use solutions containing ammonia when testing for leaks manually (ammonia, which is present in certain soaps and detergents, attacks brass connections). Although the damage may at first be impossible to detect, the cracks and leaks may appear several months after contact with the ammonia).

9.4 DIAGRAM OF LAYOUT

Europe Version

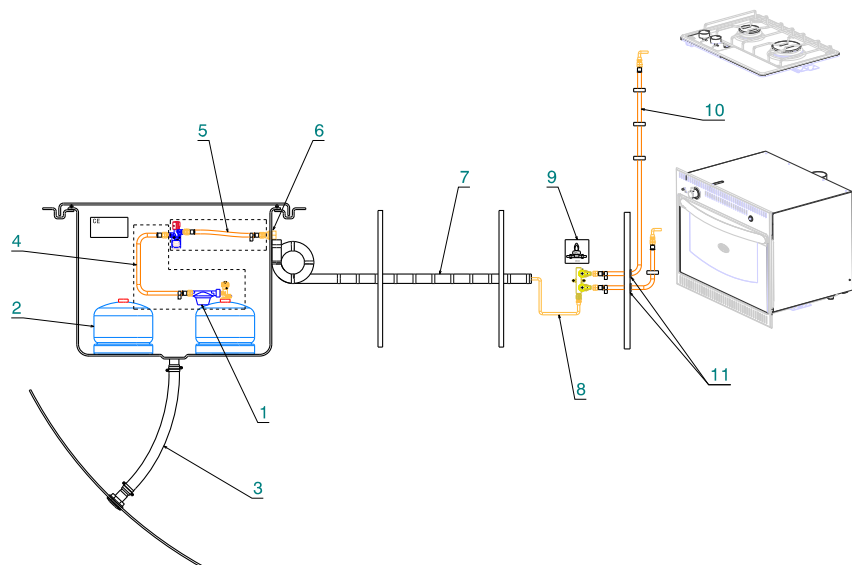

Reference	Designation
1	Regulator valve
2	Gas cylinder
3	Drain
4	Gas bottle connection kit
5	Bubble tester kit
6	Rubber washers
7	Ringed PVC sheath
8	Copper gas connection kit
9	Label
10	Gas appliance connection kit
11	Bulkhead fitting

US Version

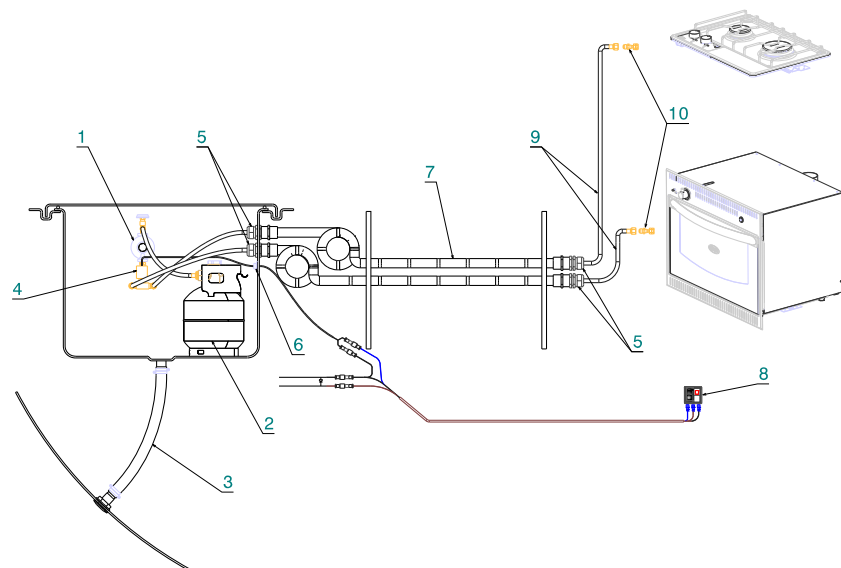

Reference	Designation
1	Regulator valve
2	Gas cylinder
3	Drain
4	Electromagnetic valve (12V)
5	Bulkhead fitting
6	Wire passage
7	Ringed PVC sheath
8	Solenoid switch
9	Plastic propane pipe
10	Gas appliance connection kit

9.5 COOKING APPLIANCES WITH BUILT-IN LPG CYLINDER

- For safety reasons, use the cooking appliance only when sea and wind conditions allow it (calm sea, low wind, moderate rolling or pitching). It is not advisable to use the griddle when under way.
- The user must remove and replace the built-in LPG cylinder in the open air and away from sources of ignition.
- Spare cartridges must be stored outside on the boat and protected from weather and mechanical damage. If a gas leak occurs, it is essential that the gas escapes outside.
- Follow the plancha supplier's instructions for use, maintenance and replacement of the LPG cartridges.

DOMESTIC APPLIANCES

■ Fridge / Cooler	126
■ Water-cooled refrigeration unit	128
■ Microwave	130
■ Dishwasher	131

10.1 FRIDGE / COOLER

General points

- The fridge comprises 3 components: the compressor, the evaporator and the condenser. These components are connected by a closed refrigerant gas circuit. The fridge is air-cooled.
- The fridge is DC powered. It is designed to chill food and drink. Any other use is dangerous and must be strictly avoided.
- A breaker protects the electrical circuit.
- The icebox (without evaporator) keeps the food and drink chilled.
- The ON/OFF start button is located on the fridge.
- The thermostat is in the inside compartment of the fridge. It enables selection of the desired temperature setting for the inside of the fridge.
- The refrigeration power can be affected by:
 - The ambient temperature,
 - The quantity of food to chill,
 - The frequency with which the door is opened.

Maintenance

- Clean the evaporator with a damp cloth at least once a year. Never use cleaners which are abrasive or acidic, or which contain solvents, for cleaning the evaporator.
- Regularly clean the fridge/icebox door seal with a damp cloth.
- Regularly defrost the fridge.
- When winterising the boat, leave the fridge door/icebox cover open to prevent mould and odours from developing.



- Refer to the manufacturer's instructions for use and maintenance.
- Never heat or use tools to defrost the inside of the fridge more quickly (doing so may damage the interior surface).
- Never obstruct the heat exchanger of the fridge.

The control is located directly inside the device.

Fridge



Cooler



10.2 WATER-COOLED REFRIGERATION UNIT

General points

The fridge comprises 3 components: the compressor, the evaporator and the condenser. These components are connected by a closed refrigerant gas circuit. The refrigerator is water-cooled.

- The refrigeration unit is supplied by direct current.
- A breaker protects the electrical circuit.
- The condenser located beneath the hull is a microbead plate. This allows optimal temperature exchange between the seawater and the coolant liquid.

Cockpit fridge



Condenser (Microbead plate)

Outside view



Refrigeration unit



- Refer to the manufacturer's instructions for use and maintenance.
- Never cover the condenser with antifouling paint.

Maintenance

Clean the refrigeration unit annually using a vacuum cleaner or a dry brush.

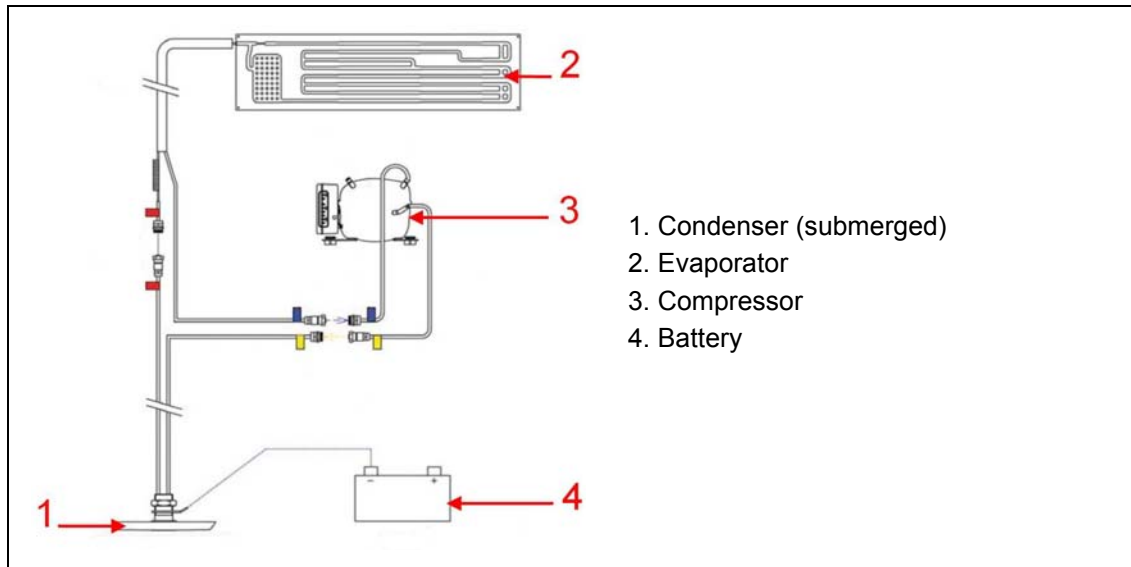

10.3 MICROWAVE

General points

- The microwave is AC powered.
- A breaker protects the electrical circuit.
- The microwave is designed to reheat food and drink or to cook food. Any other use is dangerous and must be strictly avoided.
- The microwave must never be started when empty.
- Remove all foil or metallic packaging elements before putting food in the microwave.
- Remove airtight coverings from packaging before putting food in the microwave.

Starting up

- Use the switch to select the desired power source (shore power or generator).
- Put the microwave circuit-breaker in the ON position.

Maintenance

- Regularly check the door seals.
- Regularly clean the inside of the fridge with a damp sponge.



Refer to the manufacturer's instructions for use and maintenance.

10.4 DISHWASHER

General points

- The dishwasher is AC powered.
- A breaker protects the electrical circuit.
- The dishwasher takes the water from the tanks onboard via a water feed valve.
- Dirty water is drained to the greywater tank/by draining the basin.

Starting up

- Check the level in the water tanks and switch on the water system.
- Open the valve of the water supply onboard / dishwasher.
- Turn on the AC power (shore or generator) and actuate the dishwasher's circuit-breaker.
- Turn on the dishwasher.

 Never allow children to use the domestic electrical equipment unsupervised.

 - Refer to the manufacturer's instructions for use and maintenance.
- Do not use the dishwasher when under way.

AUDIO-VISUAL EQUIPMENT

■ Television	134
■ HiFi	135

11.1 TELEVISION

General points

- Power for the television is supplied by alternating current. Depending on the equipment of the boat, alternating current may be provided by:
 - the AC shore power socket,
 - the generator,
 - the DC/AC converter powered by service batteries.
- A circuit-breaker protects the circuit.
- Pre-cabling for the aerial is already installed on the boat.

Starting up

- First turn on the circuit breaker, then switch on the TV.

11.2 HIFI

- The sound system is DC powered.
- The sound from the TV or from the DVD player is amplified by the woofer and the speakers.
- The sound from the TV comes out of the integral speakers.
- The sound from the TV can come from the speakers if AUX is selected on the DVD player.
- The sound from the DVD player comes from the speakers.
- The sound from the radio comes from the inside and outside speakers. It is possible to select either inside or outside speakers by adjusting the balance control.

Location: Starboard saloon



Interior speaker



Outside loudspeaker



Refer to the manufacturer's instructions for use and maintenance.

ONBOARD COMFORT

■ Air conditioning	138
■ Electronic equipment	146
■ Fuel-burning equipment for purposes other than propulsion (Generator, Heating)	149

12.1 AIR CONDITIONING

General points

- The air-conditioning is powered by alternating current.
- The air-conditioning cools the air temperature inside the boat (only when the boat is floating in water).
- The cooling circuit consists of one or more compressors that operate independently. A compressor is called "reversible" because it can heat the boat if the seawater temperature exceeds 13°C.
- In winter, you can programme the dehumidifier function on the air conditioning controls.
- The refrigeration compressors are made by one or two seawater pumps. These pumps are run on AC voltage and are master controlled by one or two relay boxes.
- Seawater is drained via a through-hull fitting equipped with a valve, located above the waterline. Each compressor has its own through-hull drainage fitting. It is advisable to check the flow of water visually once the air conditioning starts running.

Operation

Before starting the engine:

- Open the raw water intake valves and evacuation valves;
- Make sure that the control panel is in the STOP position;
- Use the switch on the chart table to select the power source (shore power or generator).
 - If using shore power: plug into the shore power socket;
 - If using the generator: before turning on the air conditioning, leave the generator running for approximately 3 minutes.

If the seawater pump is deprived (eg. in case of running aground), carry out the following procedure:

- Disconnect the discharge hose from the seawater pump by loosening the 2 stainless steel collars;
- Blow air through the pipe using a compressor;
- Re-connect the discharge hose with 2 stainless steel collars.

When the air conditioning is running:

- Switch the air-conditioning circuit-breakers ON.
- Select the temperature of each compressor using the control units.

DIAGRAM - AIR CONDITIONING

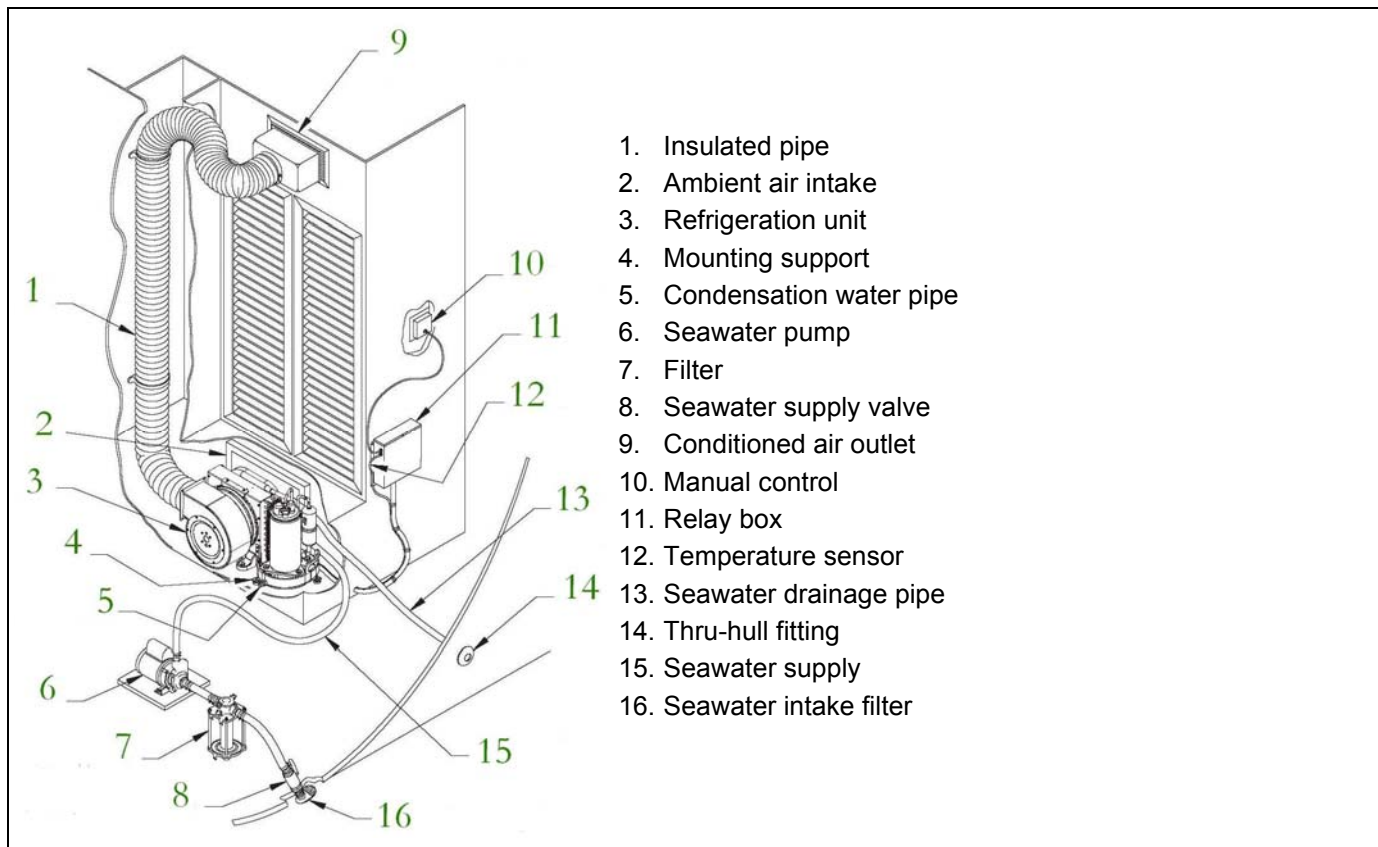

- !**
- Refer to the manufacturer's instructions for use and maintenance.
 - When the air conditioning is running, check visually that the seawater has been fully drained.
 - Never start the generator when the air conditioning is already on.
 - Always turn off the air conditioning before turning off the generator.
 - Regularly check and clean the seawater filter placed on the thru-hull seawater intake:
 - Close the seawater intake valve;
 - Unscrew the top of the filter;
 - Clean the filtering screen;
 - Put everything back in place.
 - Clean the air filter (located in the compressor) regularly for maximum performance.
 - Clean the cooling coil at least once a year.
 - To prevent the air-conditioning circuit from freezing: never run the system when the seawater temperature drops below 5°C.
 - Winterisation: drain the whole seawater system.
 - The cooling gas circuit requires no maintenance.

Air-conditioning controls

- A remote control is installed in each cabin.

Please refer to the key on the following page

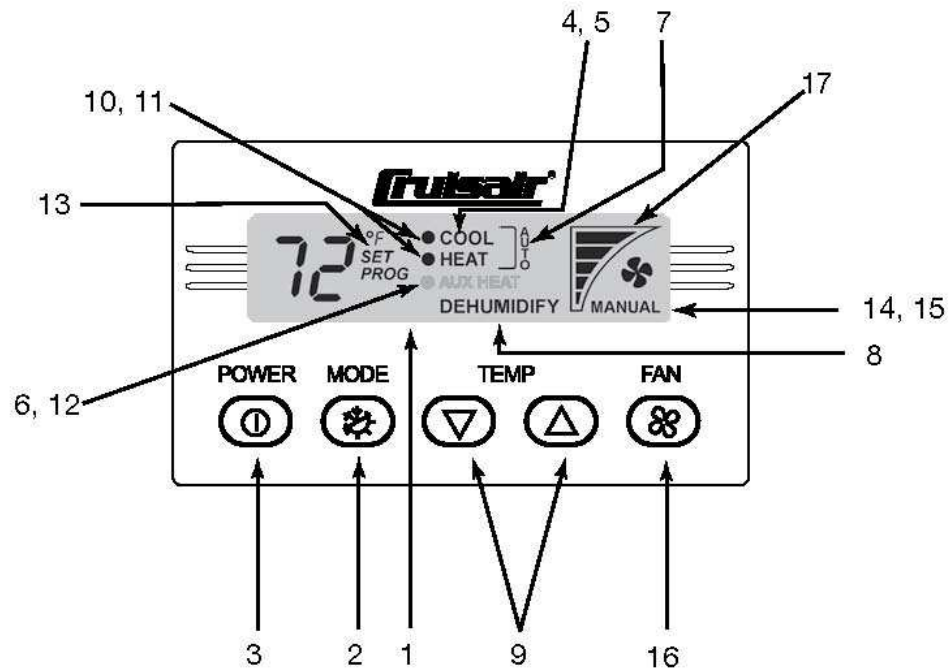

Manual control of the air-conditioning

1. Data display
Screen displaying desired temperature, programmed values and error messages.
2. MODE
Enables navigation between the different operating modes.
3. POWER/OFF
Lights up when the system is switched off. The manual ventilator may continue to run.
4. COOL
Indicates that the compressor is activated when cooling.
5. HEAT
Indicates that the compressor is activated when heating.
6. Option (Auxiliary heating).
7. AUTOMATIC
Comes on when the system is in AUTO mode.
8. DEHUMIDIFY
Comes on when the system is in dehumidifying mode.
9. + and - keys
Allow you to raise or lower the desired temperature.
10. Cooling indicator
This indicates that the compressor is in COOLING mode.
11. Heating indicator
This indicates that the compressor is in HEATING mode.
12. Option (Auxiliary heating).
13. Temperature control indicator
This indicates the temperature control setting (desired ambient temperature).
14. Indicator for the manual ventilator
This comes on when the manual ventilator is running.
15. Indicator for the automatic ventilator
This comes on when the ventilator is running in automatic mode.
16. Ventilator key
Allows you to select manual or automatic mode for the ventilator.
17. Ventilator speed indicator
Shows current ventilator speed.

NOTES

- When the system is in dehumidifying mode, the system's safety devices remain active: if there is an interruption in the flow of seawater or a drop in AC voltage, the system automatically stops.
- In cooling mode, the system works efficiently when the seawater temperature is below 30°C.
- In heating mode, the system works efficiently when the seawater temperature is above 13°C.
- It is important to switch the system to HEATING mode at least once a month to prevent the changeover cock from becoming stuck in the COOLING mode.

LOCKING METHOD

- It is possible to lock the control buttons to prevent settings from being changed accidentally: Press these three buttons simultaneously: MODE, UP (arrow pointing up), FAN. LC appears on the screen, which signifies "LOCK".
- To unlock and resume use of the buttons, press the same three buttons simultaneously: MODE, UP (arrow pointing up), FAN. UL appears on the screen, which signifies "UNLOCK".

SCREEN LIGHTING

- If the control box is switched off by a fault (in the cabins for example), touching any button automatically and instantly lights the screen up blue. To alter the light intensity of the screen, press these two buttons simultaneously: MODE, UP (arrow pointing up) until the required intensity is reached.
- It is possible to programme whether or not the controls are illuminated by default: In this case the ON mode must be selected for permanently illuminated controls or the SLEEP mode for permanently unilluminated controls.

Procedure:

- Simultaneously press these two buttons: MODE and DOWN (arrow pointing down).
- Select n°18 on the menu using the arrows, then confirm by pressing MODE.
- With the arrows select either ON for illumination by default or SL (SLEEP) to turn the box off.
- Press FAN 2 times to confirm the selection.



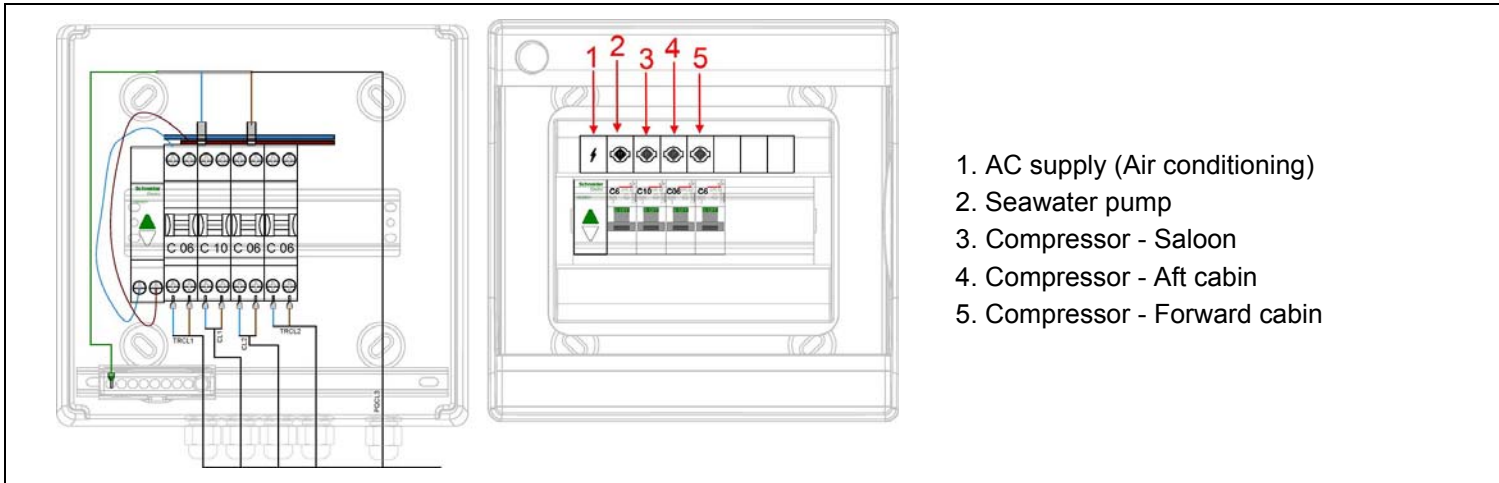

Circuit breakers

Location: Saloon

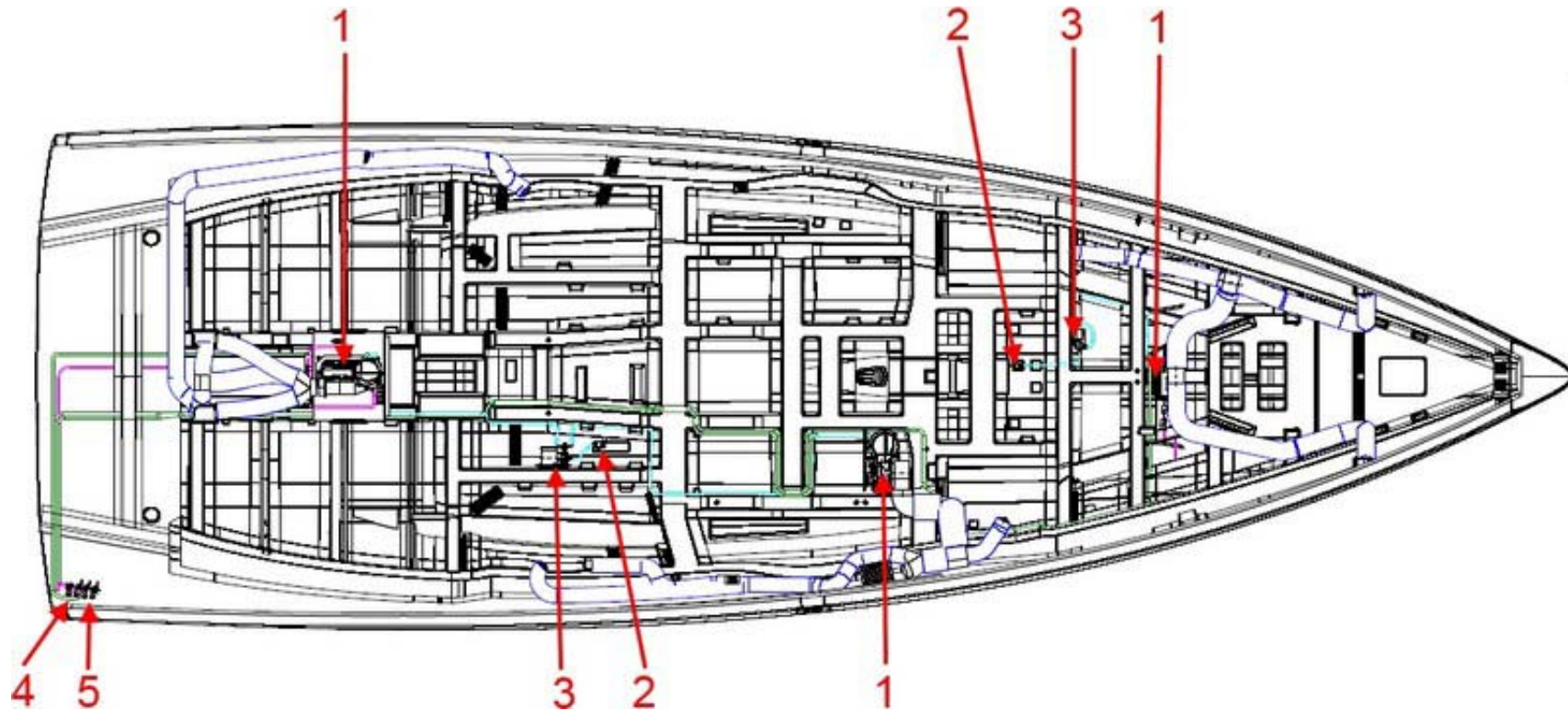

LAYOUT OF COMPONENTS



	Air distribution duct
	Seawater out
	Sea water supply
	Condensation water drainage

Reference	Designation
1	Compressor
2	Seawater intake
3	Seawater pump
4	Seawater drainage (x 3)
5	Condensation drain

DIAGRAM OF LAYOUT

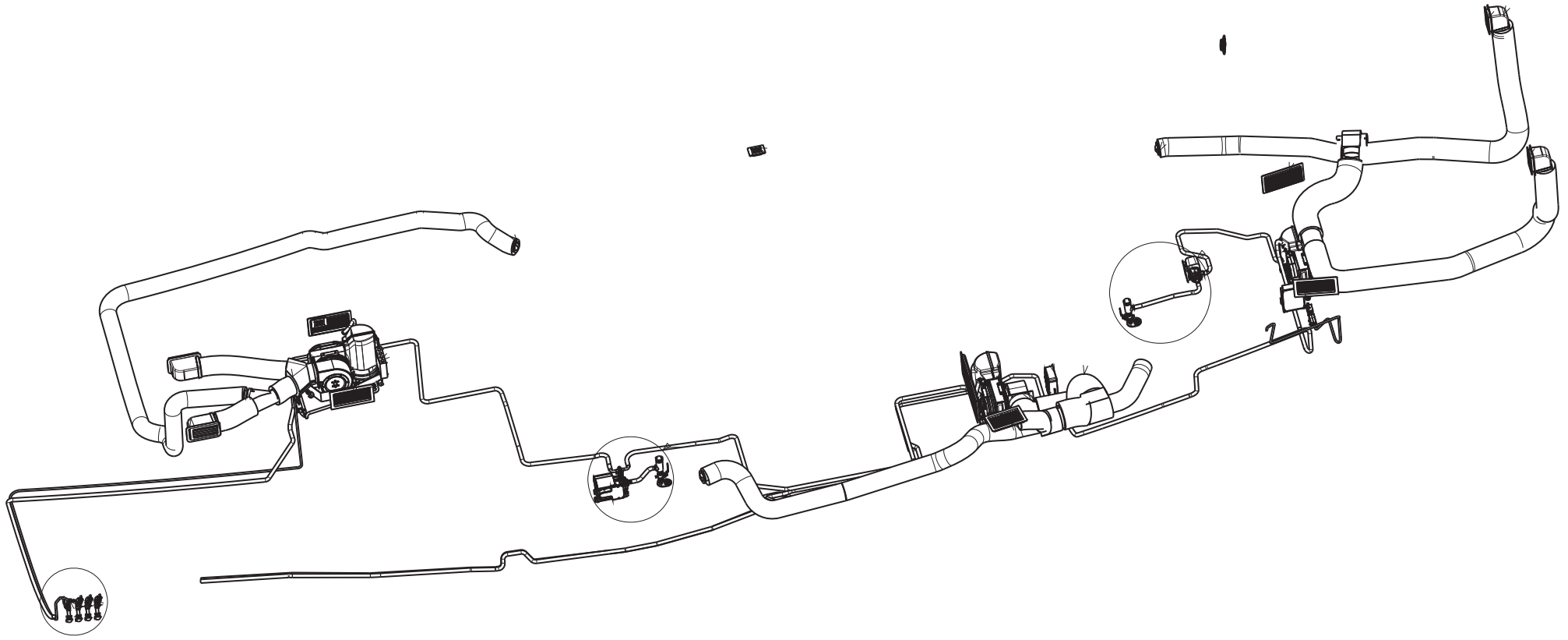

12.2 ELECTRONIC EQUIPMENT

The onboard electronics are powered by direct current.

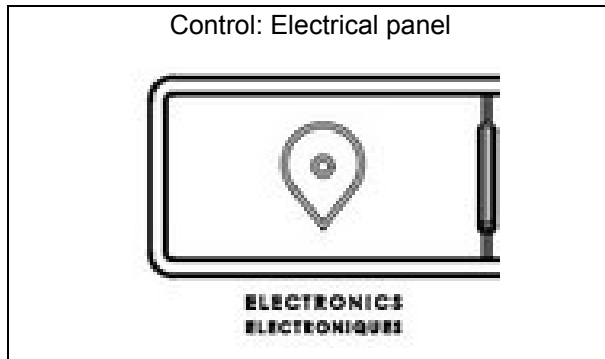

Sensors

- Do not store equipment on top of the sensors.
- Do not cover the sensors in antifoul when antifouling the hull.
- Regularly clean the sensors.

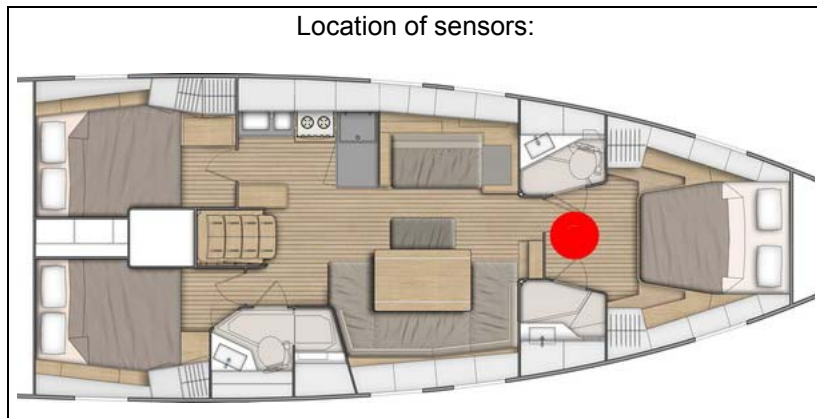

Autopilot

- To ensure optimum performance, keep all metallic objects away from the gyrocompass.
- Do not store equipment close to the calculator and electrical connections.

Control: Starboard cockpit



1. Oil reservoir
2. Hydraulic piston

VHF

Layout of components: Port saloon

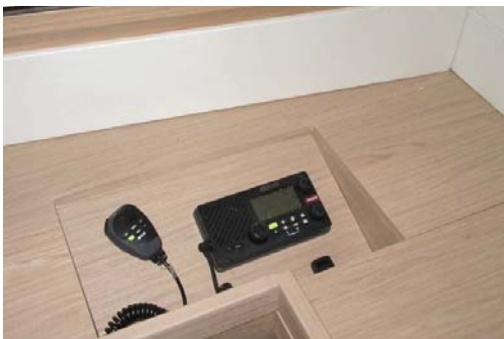

- Place the protective covers on the repeaters when unused for long periods.
- When sailing, store the protective covers inside the boat to avoid loss.
- The various repeater displays are back-lit.
- Regularly clean the dials of the repeaters with fresh water.
- Refer to the manufacturer's instructions for use and maintenance.

12.3 FUEL-BURNING EQUIPMENT FOR PURPOSES OTHER THAN PROPULSION (GENERATOR, HEATING)

12.3.1 General points

- Make sure that the ventilation openings in the engine (and, if installed, generator) compartment are well-cleared.
- Stop the engine and refrain from smoking while the fuel tank is being filled.
- Have your fuel circuit checked regularly by a professional engineer.
- Avoid any contact between inflammable materials and the hot sections of the engine.
- Take all necessary precautions to avoid contact with naked flames and other hot areas.
- Do not obstruct or modify the ventilation system.
- Fuel stored outside the tanks (jerrycans, portable fuel tanks, etc.) must be stowed on deck and protected from bad weather and mechanical damage.



- Never store fuel tanks or tanks containing petrol in any area not specifically designed for storing petrol.



Beware of the risk of falling asleep due to carbon monoxide inhalation. This is a risk associated with petrol engines..

12.3.2 Generator

DIAGRAM OF LAYOUT

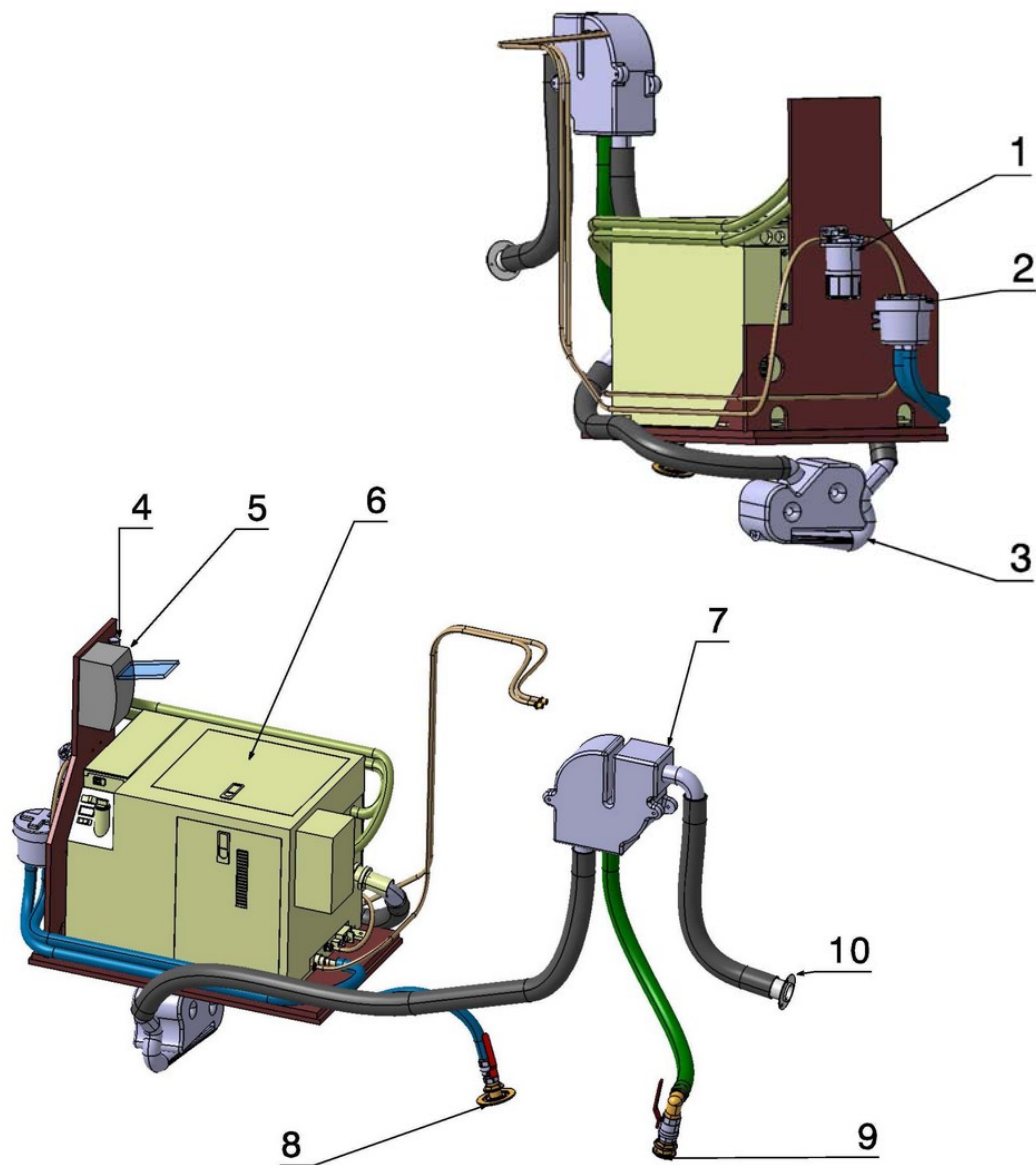

Reference	Designation
1	Fuel filter
2	Seawater filter
3	Water trap
4	Anti-siphon valve
5	Differential circuit breaker
6	Generator
7	Water/gas separator
8	Seawater inlet
9	Seawater drainage
10	Outlet

General points

- The generator is a machine which can produce AC electrical power using mechanical power (fuel). The generator powers onboard equipment operating at 220V or 110V, moored or sailing.
- The generator starts with its own battery (12V circuit).
- Make sure that there is enough fuel in the fuel tank before using the generator. The generator is fed by fuel through the fuel tank.
- The cooling water and exhaust gases are separated in the separator to avoid noise pollution. The seawater is discharged below the waterline. The exhaust- pipe is located above the waterline. Check visually that the exhaust gases are being expelled properly.
Make sure that the ventilator in the generator compartment is working.
- Check to see if any leaks appear (seawater, coolant, fuel, exhaust gases). If there is a leak, stop the generator at once and have the leak repaired.
- The generator is earthed by an earthing plate which is located under the hull (see Chapter: EARTHING PLATES).
- Maintenance of the generator must only be done by qualified and proficient personnel. Before working on the generator, it is imperative to isolate the generator's battery power, to prevent it from starting accidentally.
- The generator can be started by the switch on the generator itself or by the switch on the control panel.

Starting up

- Fill the generator with water to prevent the seawater pump from running dry (refer to the supplier's recommendations).
- Open the raw water intake valves and evacuation valves.
- Open the fuel supply valve.
- Turn the generator's battery switch to the ON position.
- Switch the generator's circuit-breaker to the ON position.
- Turn on the generator using the remote control (located near the main switch panel).
or on the generator itself.
- Make sure that no AC equipment is running. Toggle the shore power/ generator switch.

In the event of the generator catching fire

- Do not open the generator.
- Cut the power supply (electrical and fuel) to the boat's engines, to the generator and to the ventilators.
- Use the extinguisher access port on the generator to discharge the contents of the portable extinguisher.



- Refer to the manufacturer's instructions for use of the generator.
- Never start the generator when the air conditioning is already on. Always turn off the air conditioning before turning off the generator.
- Never connect the shore power to the generator: you may suffer an electric shock.
- An extinguisher access port is provided on the generator in the event of a fire starting in the generator.

12.3.3 Warm air heating system

General points

- The heating is powered by DC supply. The electrical supply is provided by the onboard battery bank.
- A fuse protects the circuit.
- You are advised to run the heating system for about 15 minutes every month (to prevent the operating components from becoming blocked and to refresh the fuel in the pipeline).
- The warm air heating system, installed at the back of the boat, draws in outside air via an integrated ventilator.
- The air warmed in the heating system is blown through the warm air ducts to the living area of the boat.
- Fuel is supplied from the fuel tank via a feed pump.
- The combustion system is separate from the heating system: The air intake for combustion is separate from the warm air heating system.
- The exhaust gases are expelled to the outside by an exhaust pipe with a silencer.
- The heating system compares the actual temperature with the desired temperature and automatically adjusts the heating power required.

Annual maintenance

- Clean or replace the fuel filter.
- Check that the heating ducts are in good condition.

Manual control

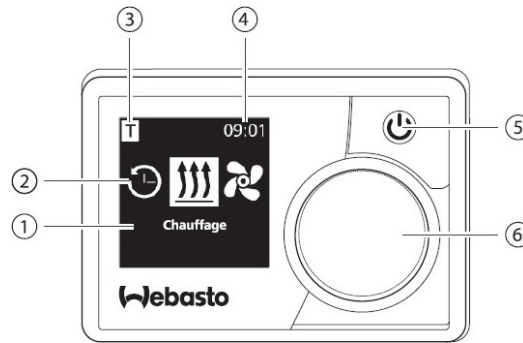

1. Name of menu element
2. Menu symbol
3. Preset duration activated
4. Clock
5. ON / OFF control button
6. Control button (rotating and push button) to choose and confirm the desired function

The colour of the ON / OFF start button indicated the heating appliance status:

- continuous green: Heating
- continuous blue: Ventilation
- continuous white: Boiler off
- flashing red: Fault / no heating
- flashing green: Pre-programmed heating
- flashing blue: Pre-programmed ventilation

- !**
- Please refer to the manufacturer's instructions for the use and maintenance of the heating system.
 - A sudden cut in the electrical supply may damage the heater: **REMEMBER TO SWITCH OFF THE HEATER BEFORE ISOLATING THE BATTERIES.**
 - It is essential to disconnect the electrical supply and to allow the hot components to cool before doing any maintenance or work on the heater.

DESCRIPTION OF PICTOGRAMS

































	Timer menu		Ventilation menu
	Heating menu		Settings menu
	Normal heating mode		Eco heating mode
	Boost heating mode		Ventilation speed (speeds 1 to 4)
	Add the time programmer		Activate the time programmer
	Deactivate the time programmer		Delete the time programmer
	Delete all time programmers		Time programmer activated
	Instant starting		Day of the week
	Hour		Language
	Unit of temperature		Day / Night
	System information		Error information
	Reset (reset / return)		Repair - Please contact the repair and maintenance centre
	Left		Warning
	Back		Right
	12-hour display		OK
	Switched on		ADR

DIAGRAM OF LAYOUT



Reference	Designation
1	Diesel tank
2	Metering pump
3	Control box
4	Heater
5	Fresh air intake
6	Heating exhaust
7	Hot air openings

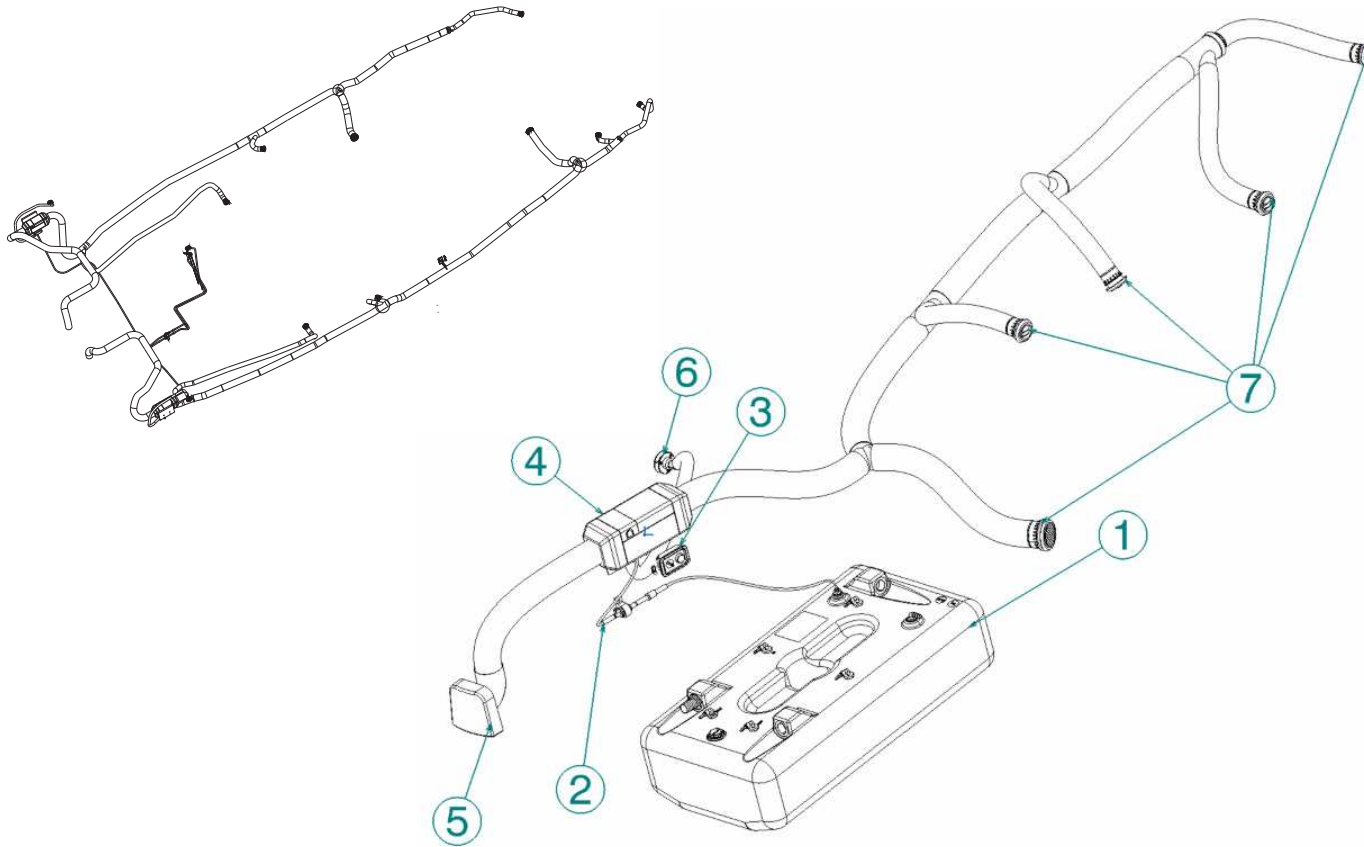

- The heater must be switched off when refilling the fuel tank.
- The heater's exhaust gases are very hot: they may burn fenders or cables located too close to the through-hull exhaust.

WATER SYSTEMS

■ General points	158
■ Using a valve.....	159
■ Fresh water filling system	160
■ Fresh water distribution system	163
■ Main plumbing equipment.....	168
■ Blackwater system (Toilet)	179
■ Waste water system	195

13.1 GENERAL POINTS

- It is essential to rinse the entire on-board water system the first time the boat is used (the water system is protected in the factory by a non-toxic antifreeze).
- The water tanks may have had an anti-algae treatment using a copper sulphate based product. It is advisable to renew the treatment according to the area in which the boat is sailing.
- Drain all the water systems during winterisation (in particular the cockpit shower and water heater) to avoid damage from freezing.
- Clean/change the filters regularly.



- Regularly check water-tightness of joints in the water system installations. Check that screws and bolts are well tightened and replace them if they are worn or corroded.
- Disconnect the onshore shore water supply before leaving the boat (if fitted).
- If the boat is sailing in temperatures below freezing, antifreeze can be used in the water systems: use a non-toxic antifreeze for potable water.

**NEVER USE AUTOMOBILE ANTIFREEZE:
RISK OF POISONING.**

13.2 USING A VALVE

The valve is closed when the valve handle is at right angles to the pipe. The valve is open when the valve handle is in line with the pipe.

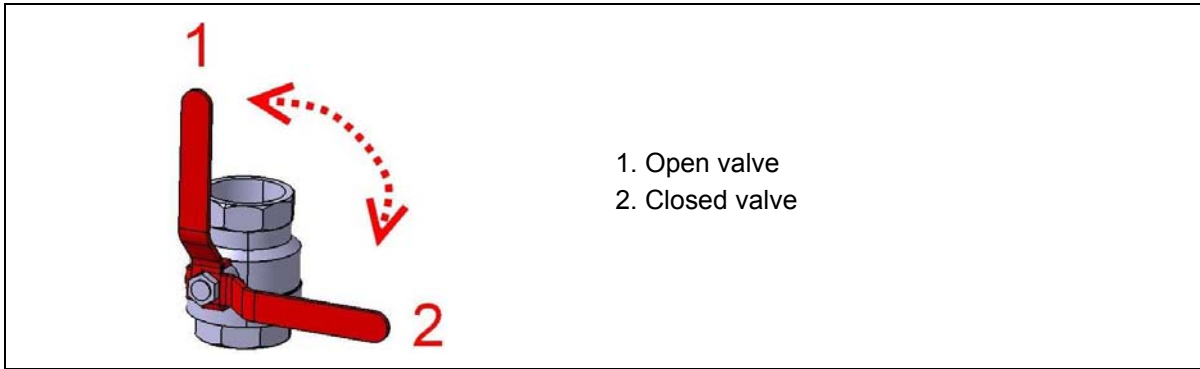

Using the drainage valve

- The direct-to-sea drainage valve can be sealed by means of the drilled hole on the handle.
- To lock the drainage valve in the closed position: Pass the tightening collar around the drainage valve and feed through the hole in the handle as shown.

Plastic valve



Bronze valve







Valves, thru-hull inlets and other brass or bronze fittings have a lifespan of around 5 years. All valves, thru-hull inlets and other brass or bronze accessories must be checked by a professional every year and replaced as necessary.

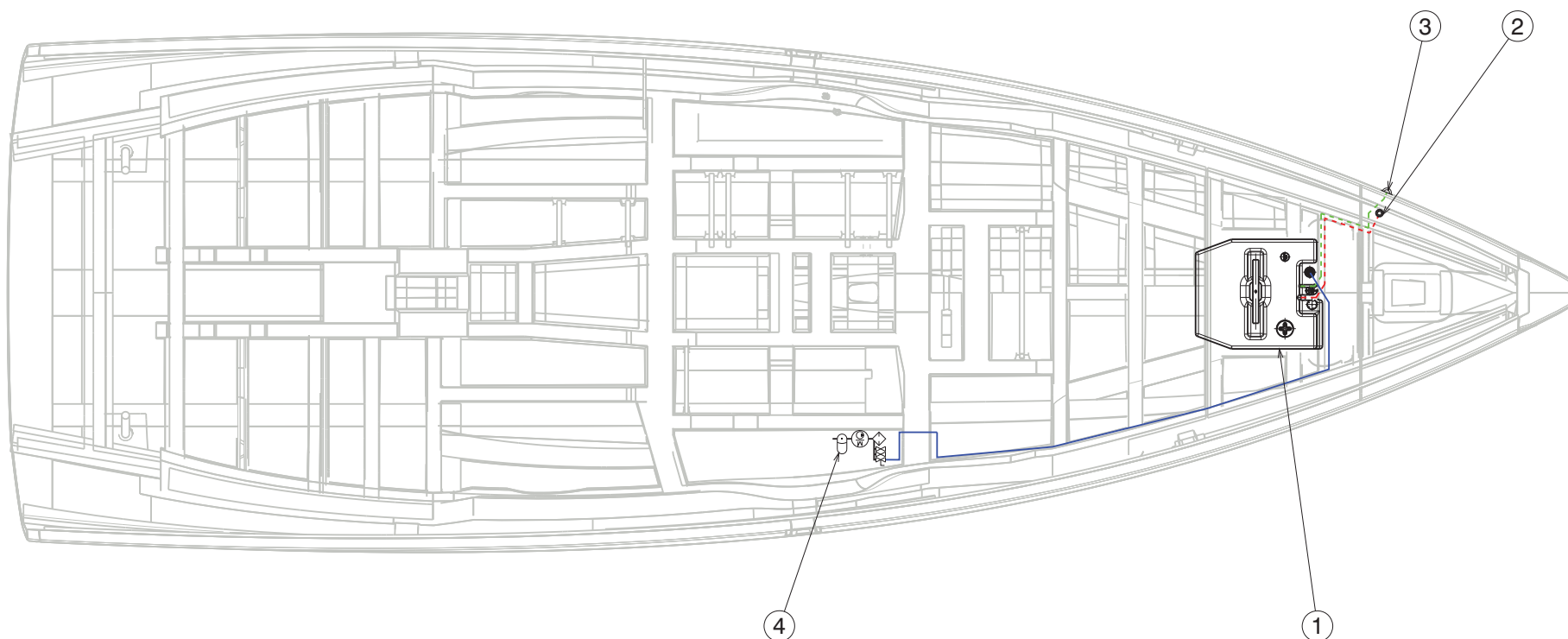

- Beware of any unintentional draining.

13.3 FRESH WATER FILLING SYSTEM



	Supply pipe - 12mm diameter
	Vent pipe - 16mm diameter
	Pipe filling - 38mm diameter

Reference	Designation
1	Fresh water tank
2	"WATER" deck filler
3	Fresh water tank vent
4	Water unit

Extra water tank

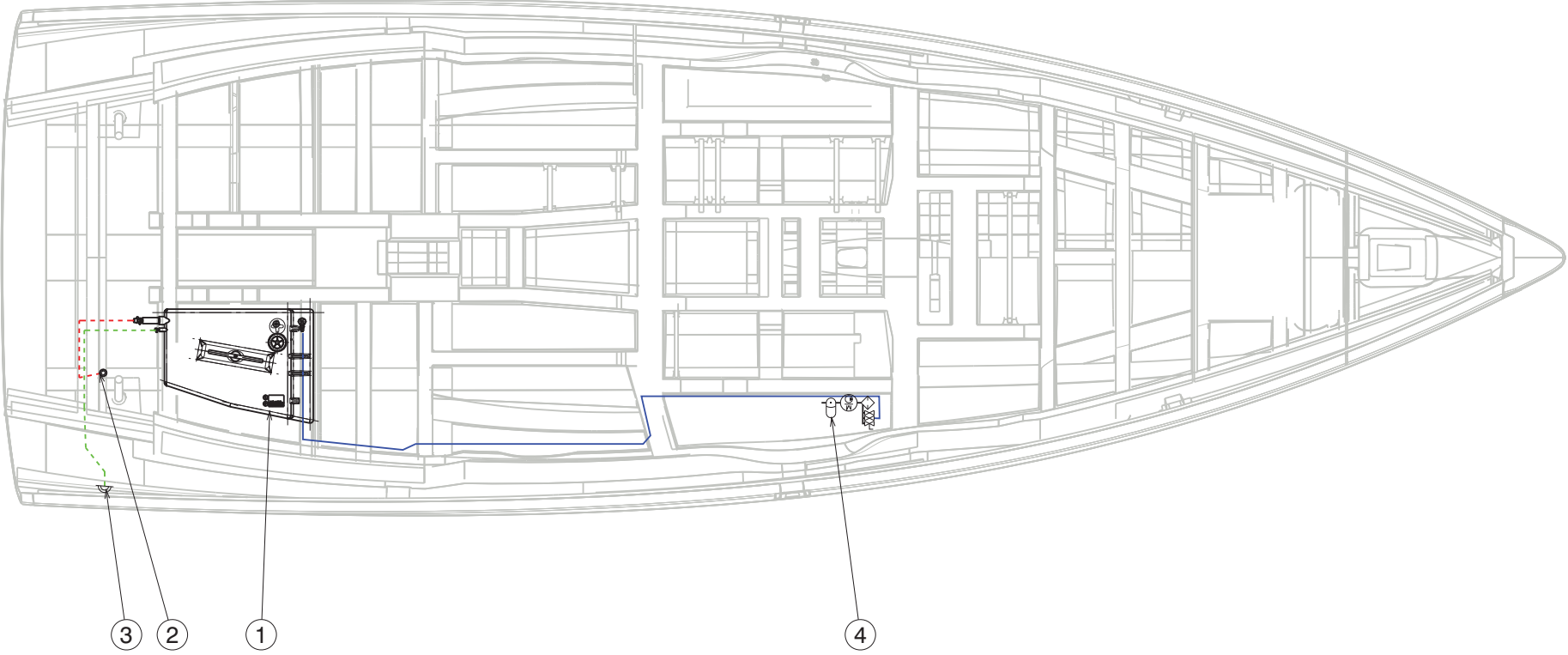

	Supply pipe - 12mm diameter
	Vent pipe - 16mm diameter
	Pipe filling - 38mm diameter

Reference	Designation
1	Fresh water tank
2	"WATER" deck filler
3	Fresh water tank vent
4	Water unit

Water tanks

Forward cabin



Starboard aft cabin (Extra water tank)



Gauge: Touch screen



Water tank selection valves



1. Supply - Forward tank
2. Supply - Extra tank (aft)

13.4 FRESH WATER DISTRIBUTION SYSTEM

3 cabins 2 heads version

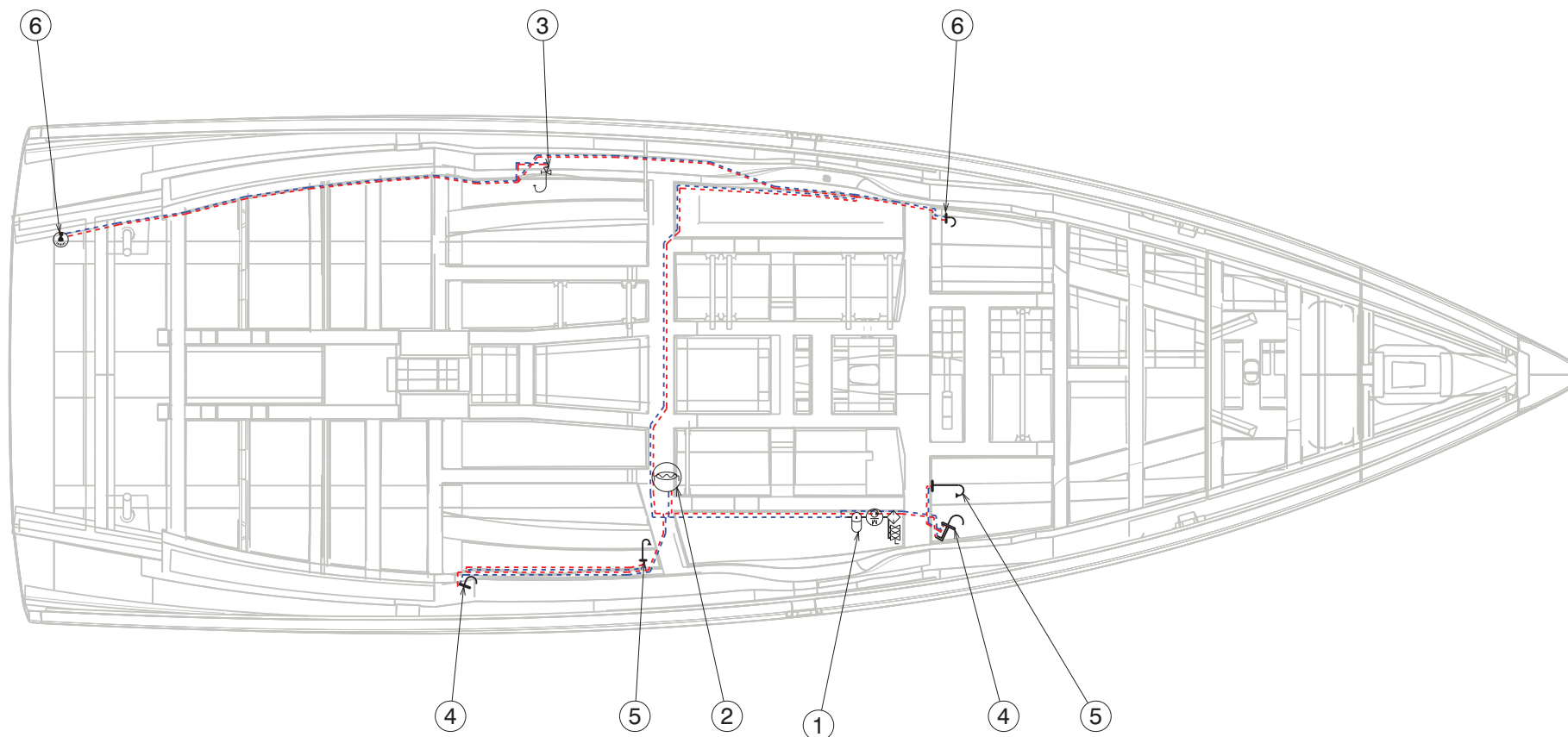

	Cold water system - 19mm diameter
	Hot water pipe - 19mm diameter
	Cold water system - 12mm diameter
	Hot water system - 12mm diameter

Reference	Designation
1	Water unit
2	Water heater
3	Sink mixer tap (Galley)
4	Washbasin mixer tap (Head)
5	Mixer shower
6	Washbasin/shower mixer tap

3 cabins 3 heads version

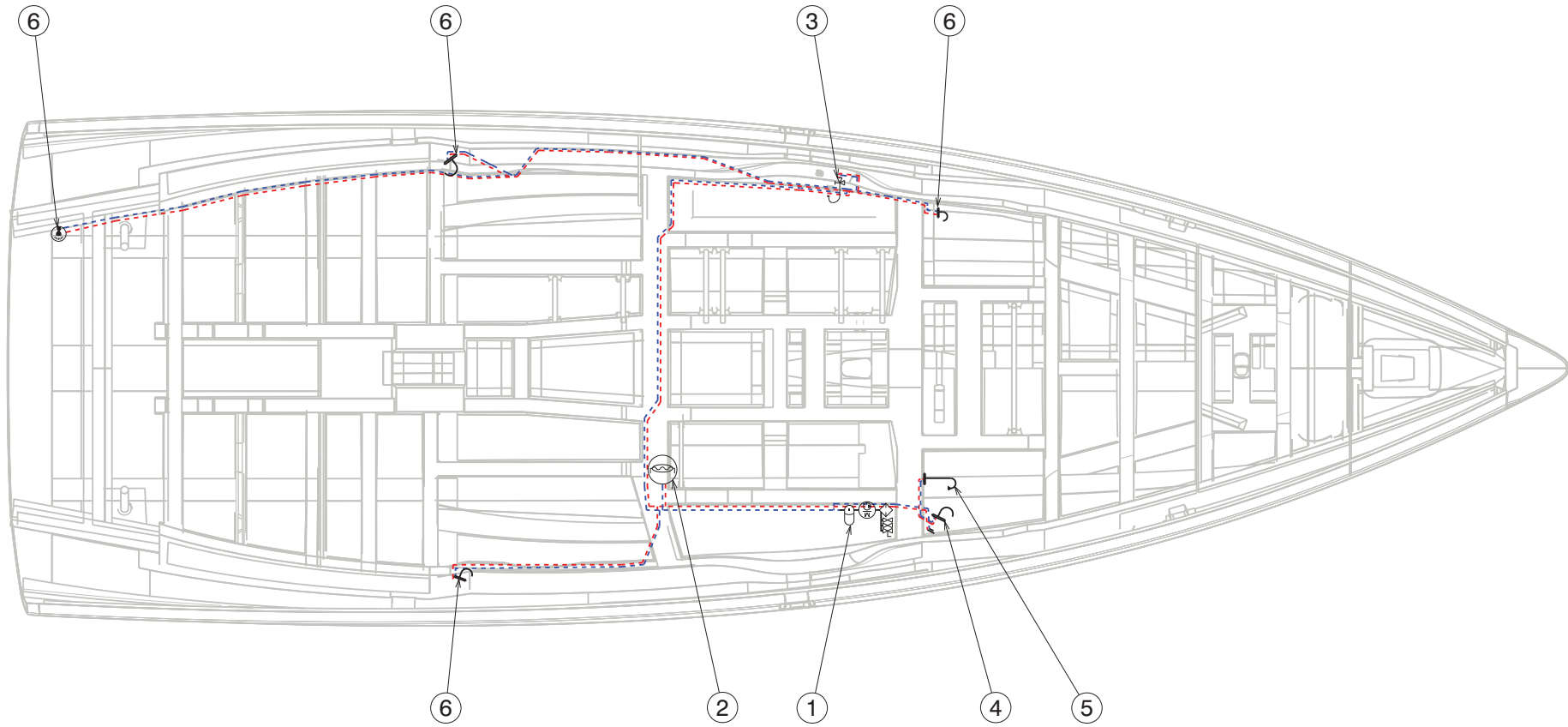

	Cold water system - 19mm diameter
	Hot water pipe - 19mm diameter
	Cold water system - 12mm diameter
	Hot water system - 12mm diameter

Reference	Designation
1	Water unit
2	Water heater
3	Sink mixer tap (Galley)
4	Washbasin mixer tap (Head)
5	Mixer shower
6	Washbasin/shower mixer tap

4 cabins 2 heads version

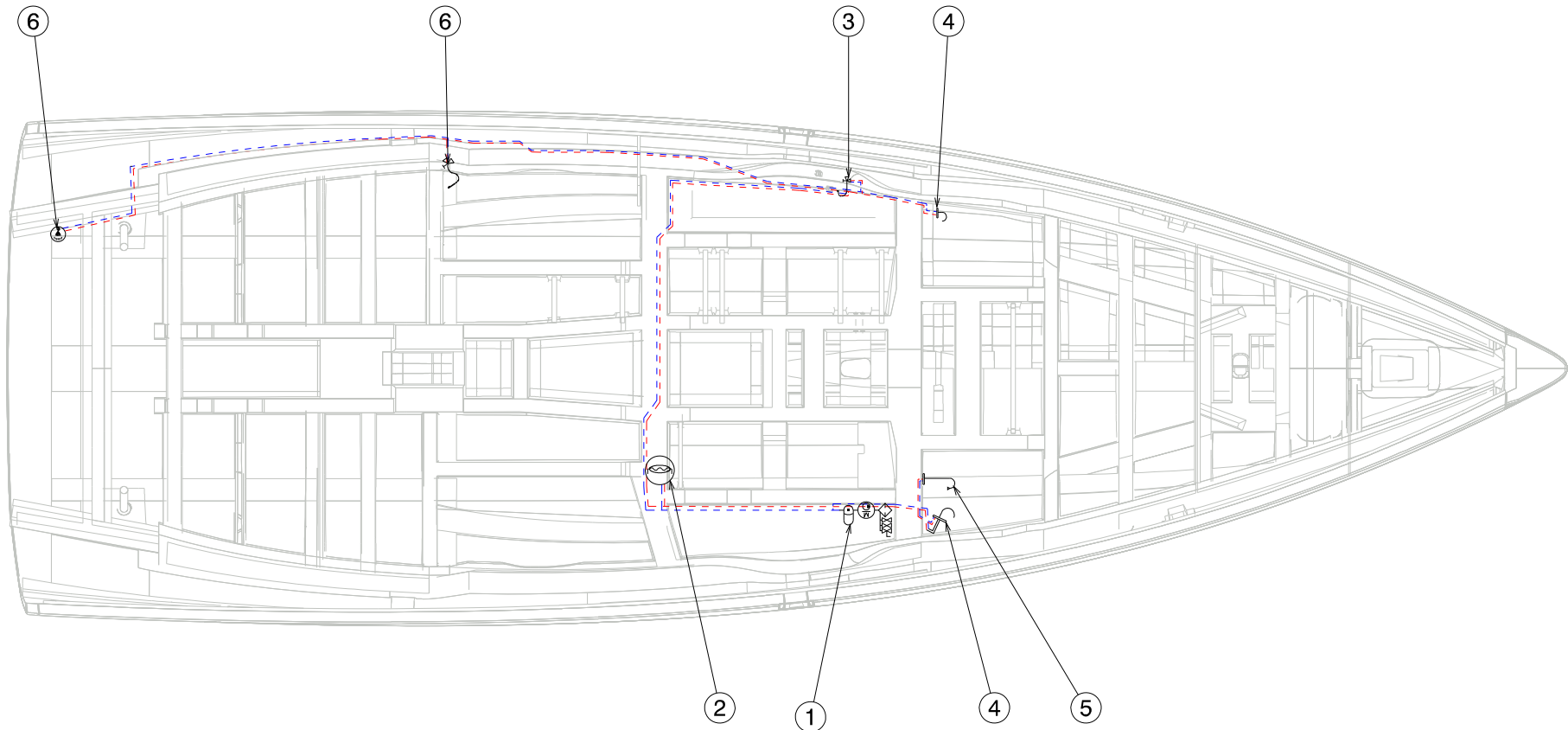

	Cold water system - 19mm diameter
	Hot water pipe - 19mm diameter
	Cold water system - 12mm diameter
	Hot water system - 12mm diameter

Reference	Designation
1	Water unit
2	Water heater
3	Sink mixer tap (Galley)
4	Washbasin mixer tap (Head)
5	Mixer shower
6	Washbasin/shower mixer tap

4 cabins 4 heads version

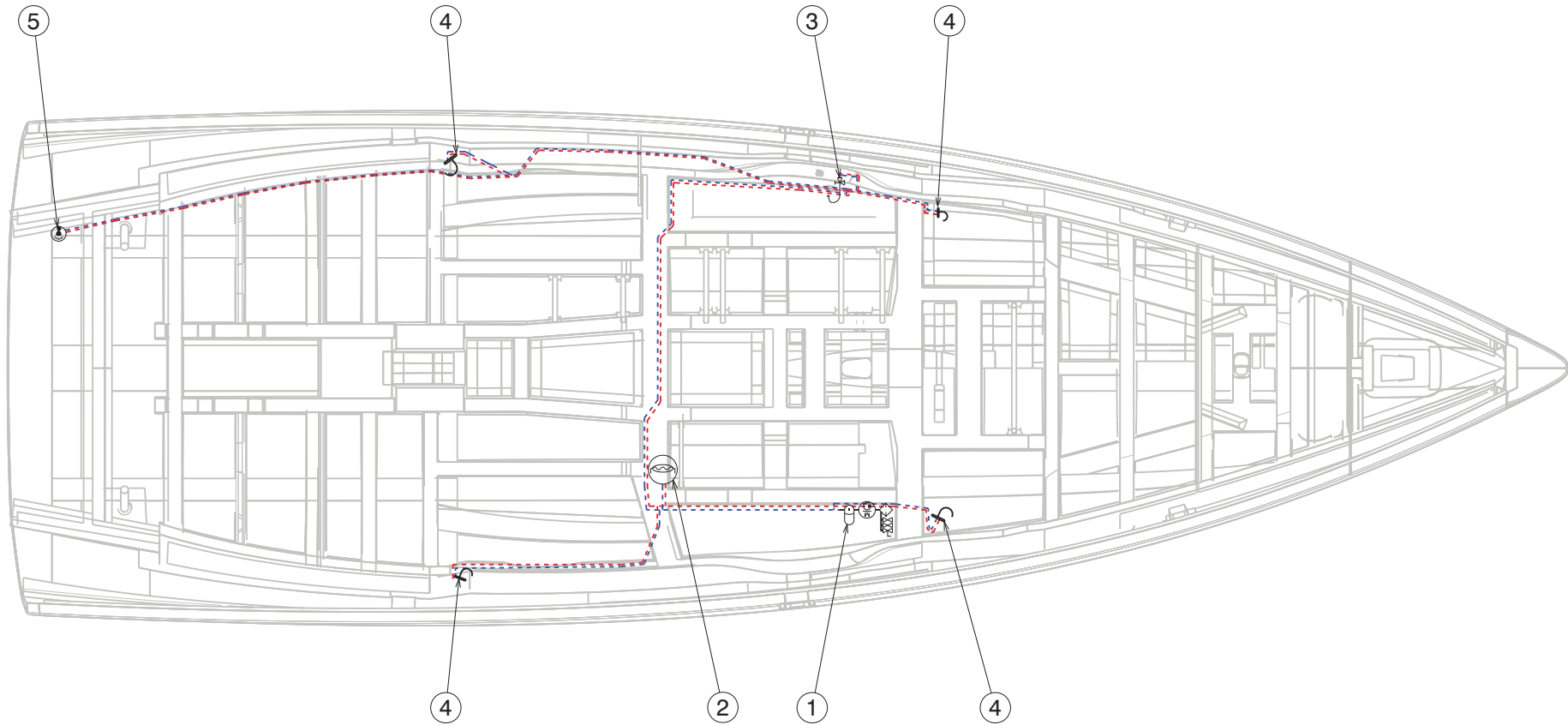

	Cold water system - 19mm diameter
	Hot water pipe - 19mm diameter
	Cold water system - 12mm diameter
	Hot water system - 12mm diameter

Reference	Designation
1	Water unit
2	Water heater
3	Sink mixer tap (Galley)
4	Washbasin mixer tap (Head)
5	Mixer shower

5 cabins 3 heads version

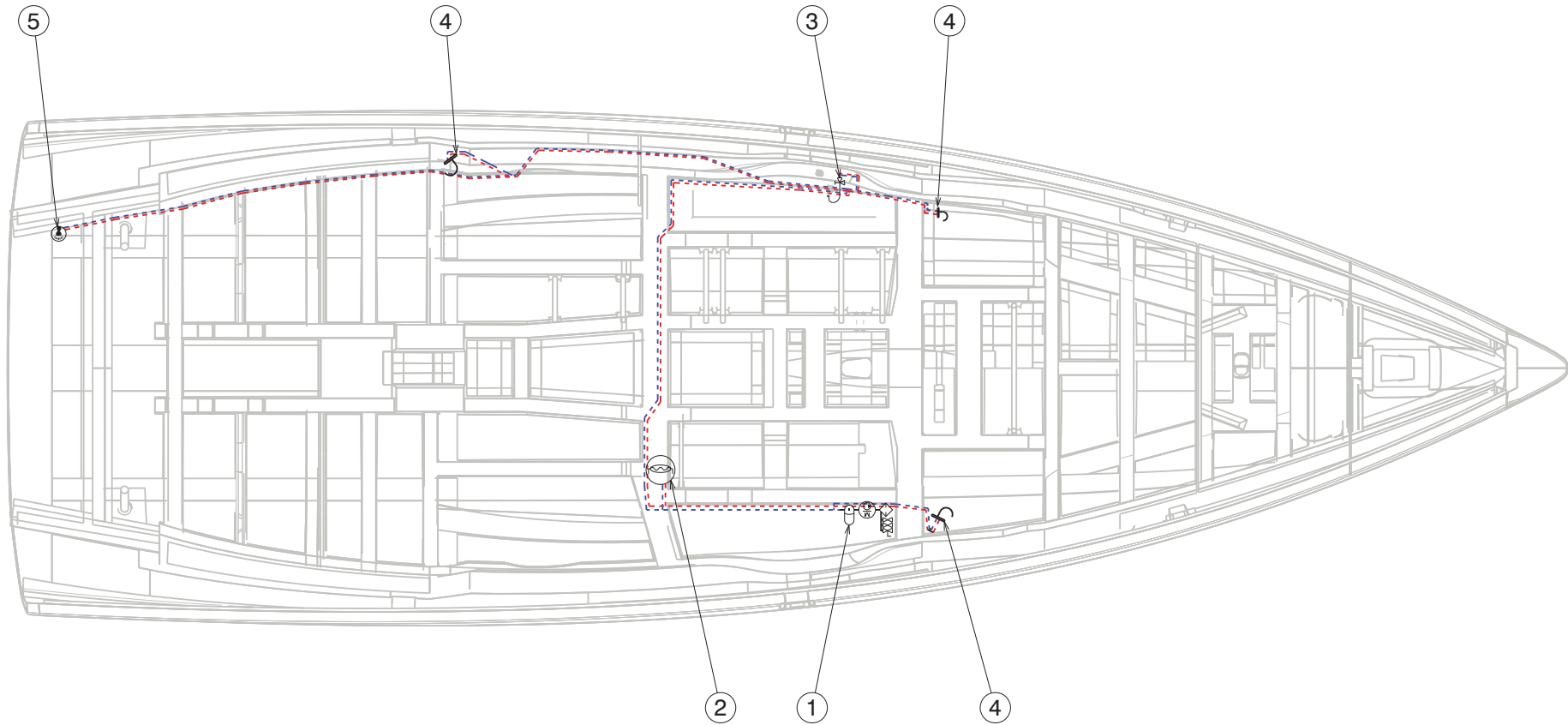

	Cold water system - 19mm diameter
	Hot water pipe - 19mm diameter
	Cold water system - 12mm diameter
	Hot water system - 12mm diameter

Reference	Designation
1	Water unit
2	Water heater
3	Sink mixer tap (Galley)
4	Washbasin mixer tap (Head)
5	Mixer shower

13.5 MAIN PLUMBING EQUIPMENT

13.5.1 Water unit

- The water unit is powered by direct current.
- It supplies all the boat's plumbed-in equipment with fresh water. It is fitted with a pressure switch that activates the flow when the pressure in the water system falls.
- The water unit must only be used with the fresh water supply. All other use (e.g. seawater, bilge water, oil products) must be strictly avoided.
- The water unit is switched on at the electrical panel.
- Make sure that the water unit never runs dry.
- The pressure and capacity of the water unit depend on the temperature of the stored fresh water supply.

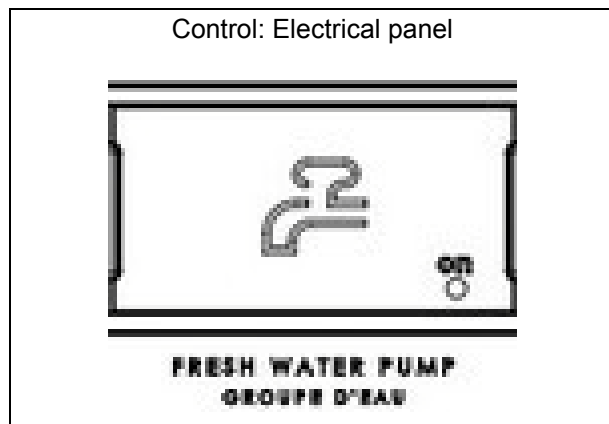

- When the water unit is powered by the DC circuit, the switch lights up in red.
- When the ON indicator turns green, the water unit is operating.

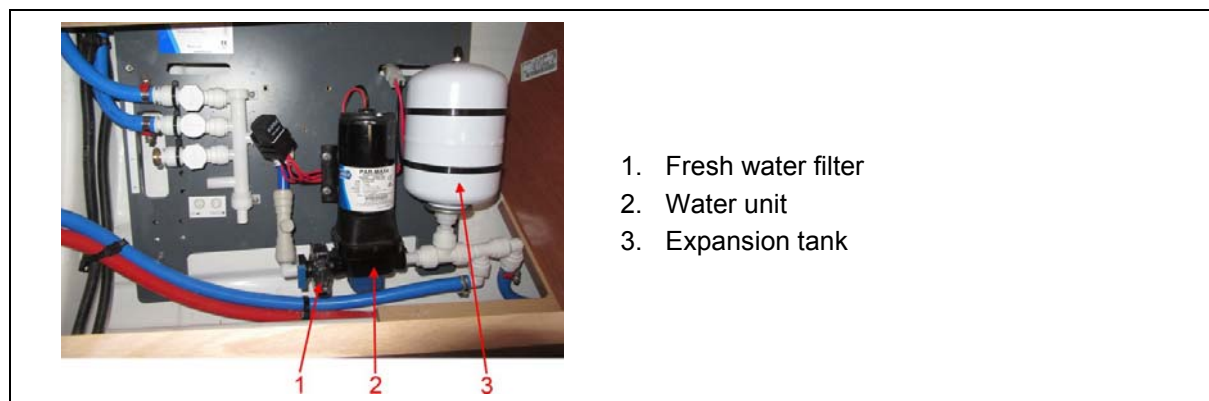

13.5.2 Cockpit shower

- The cockpit shower provides fresh water for rinsing off.
- The shower is fitted with a mixer tap.
- The tap has a dual function:
 - It allows the water to be turned on or off,
 - It allows a choice of water temperature (hot water / cold water).

Operation

- To use the shower, turn on the water by tipping the tap on its axis.
- Press the button on the top of the shower to allow the flow of water.
- Choose the required temperature by turning the tap clockwise or anti-clockwise.
- After using the shower, it is important to turn off the water by tipping the tap back into its original position.



13.5.3 Deck wash pump (seawater/fresh water)

- The deck wash pump is supplied by direct current.
- The deck wash pump allows the deck or the boat's tender to be washed.
- The deck wash pump is switched on at the helm station.

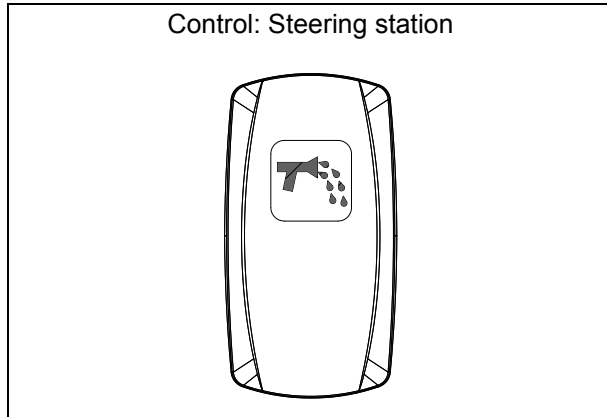



Operation

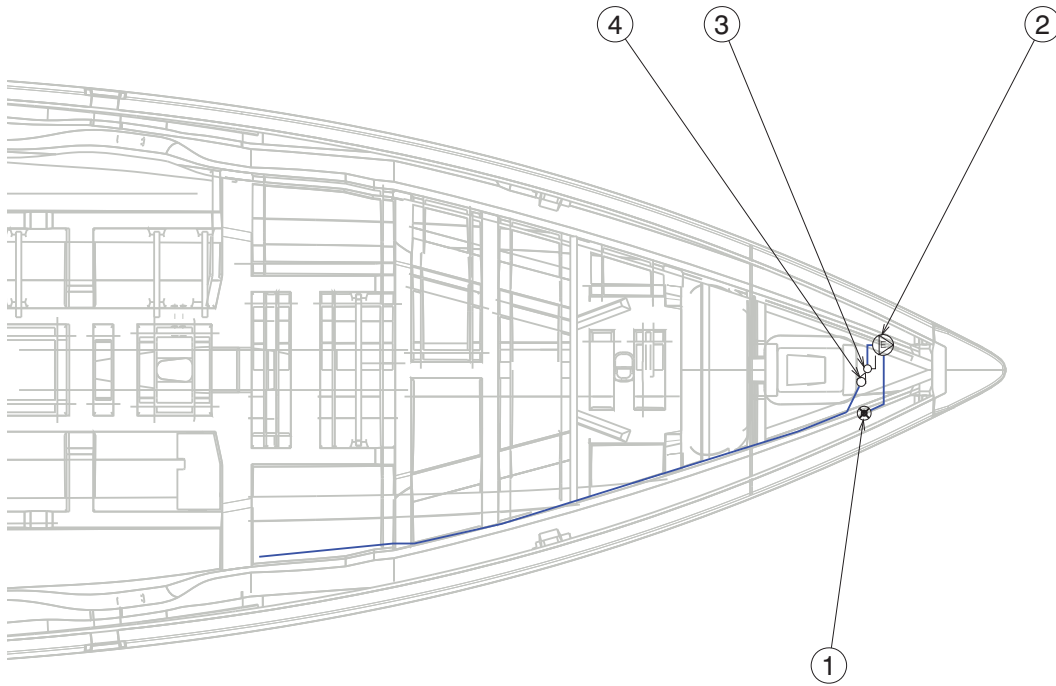

- Open the seawater intake valve.
- Select the seawater or fresh water supply.
- Attach a hose to the connector provided in the cockpit.
- Start the pump.

DIAGRAM OF LAYOUT



	Supply pipe - 19mm diameter
---	-----------------------------

Reference	Designation
1	Connection
2	Deck wash pump
3	Seawater intake
4	Non-return valve

13.5.4 Shore fresh water supply

General points

There are two options for supplying the fresh water circuit of the boat:

1. via the water unit supplied by one or more water tanks,
2. by fresh water taken from the dock.

These two possibilities of supplying fresh water circuit of the boat are independent from each other.

1. Supply of the fresh water circuit by the water unit and the water tanks

- Open the valve of the desired water tank located near the water unit (if the boat has several water tanks, it is advisable to open only one valve at a time).
- Switch on the water unit.

2. Supply of the fresh water circuit by taking fresh water from the dock

- Connect a water pipe to the onshore water supply.
- Open the water supply tap located on the pontoon.
- A non-return valve in the distribution circuit allows the shore supply water to be used without opening the valve.
- The connection of the water intake is located in the cockpit.



 Disconnect the onshore shore water supply before leaving the boat.

NOTES

- The water from the onshore supply is delivered under pressure directly into the onboard water circuit. It is not necessary to switch on the water unit.
- It is not possible to fill up the water tanks using the onshore water supply.

13.5.5 Sea water/fresh water foot pump

- The foot pump enables the use of sea water/fresh water without the need for electricity.
- Water from the foot pump comes out at the spout located at the sink.

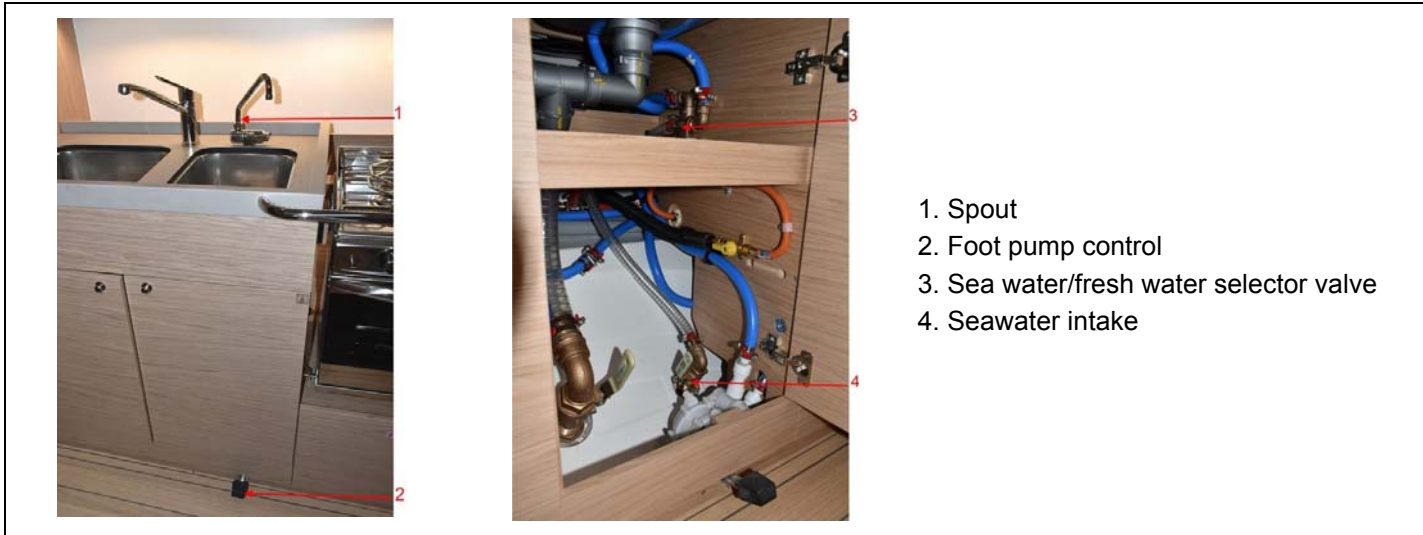

13.5.6 Water heater

- The water heater enables the use of hot water on board the boat.
- The water heater operates by heat recovery from the engine cooling circuit or the on board AC electrical supply.
- The water heater thermostat regulates the water temperature only when it is operating with electrical resistance. The thermostat is pre-set in the factory.
- The mixer tap allows the temperature leaving the water heater to be adjusted.
- Never switch on the water heater if it is not filled with water.

 Refer to the manufacturer's instructions for use and maintenance.

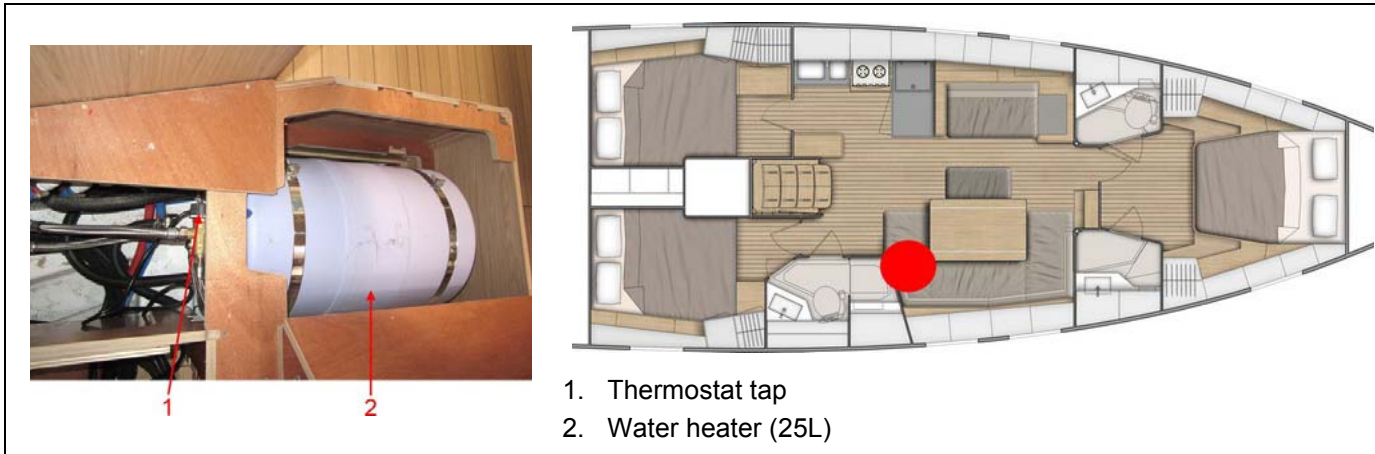

13.5.7 Ice making equipment (Ice maker)

General points

- The ice maker provides a supply of ice from the onboard water system.
- The ice maker runs on the AC power supply.
- A circuit-breaker protects the circuit.

Operation

- The ice maker is supplied with water from the tanks via a supply valve.
- Turn on the water unit to supply water to the ice maker.
- Open the onboard water/ice maker supply valve.
- Turn on the AC power (shore or generator) and actuate the ice maker circuit-breaker.
- Start the ice maker using the control on the appliance.

Maintenance

- A carbon filter is installed in the ice maker water system. Change the filter regularly.
- Clean the evaporator with a damp cloth at least once a year. Never use cleaners which are abrasive or acidic, or which contain solvents, for cleaning the evaporator.
- Clean the hinge of the ice maker door regularly with a damp cloth.
- Clean and defrost the ice maker regularly.
- During overwintering, leave the ice maker door open to avoid the formation of mould and odours.
- During prolonged absences, drain the ice maker system to avoid damage from freezing.



- Refer to the manufacturer's instructions for use and maintenance.
 - Never heat or use tools to defrost the inside of the fridge more quickly.
 - Never obstruct the heat exchanger of the fridge.

13.5.8 Watermaker

General points

- The watermaker allows fresh water to be produced from the seawater.
- The watermaker can be supplied either:
 - by DC (direct current),
 - by AC (alternating current).
- A circuit-breaker protects the circuit.
- The watermaker circuit comprises several elements:
 - seawater intake,
 - seawater filter(s),
 - circulation pump,
 - electric valve for automated rinsing,
 - manual rinsing valve,
 - motor block and high-pressure pump,
 - membrane block,
 - control panel,
 - seawater discharge valve.

Operation

- Seawater enters the membrane block under pressure, which allows only pure water to pass out.
- A sensor at the membrane block outlet allows measurement of the salt content of water filtered in this way. A three-way valve allows drinking water to be directed automatically to the tanks or for water that is too salty to be discharged to the sea.
- The drinking water filtered by the membranes is sterile; it is advisable to treat it with a weak dose of chlorine from time to time and to mineralise it if consumption is prolonged.
- Fresh water production is affected by the temperature of the seawater used and the cleanness of the filter.

Operation

- Before starting the watermaker circuit, check that the supply and discharge valves are open.
- Using the watermaker with DC supply needs a lot from the battery bank: make sure to recharge them regularly by running the boat's engine.
- The different quality and salinity of the seawater used affect the production of fresh water; it is advisable not to use the watermaker in areas of heavy sail traffic or where the water is muddy, polluted or brackish.
- The membranes are temperature-sensitive; in the event of negative (0°C and less) or too hot (60°C and over) temperatures, the membranes are likely to tear.

Maintenance

- Every week, rinse the system with fresh water. This can be done manually or automatically as preferred. The fresh water used for rinsing the circuit must not be under pressure as this can damage the membranes.
- Every 6 months, the seawater filter must be changed.
- When the watermaker is not being used for a long period, rinse the system every month or sterilise the membranes.

DIAGRAM OF LAYOUT

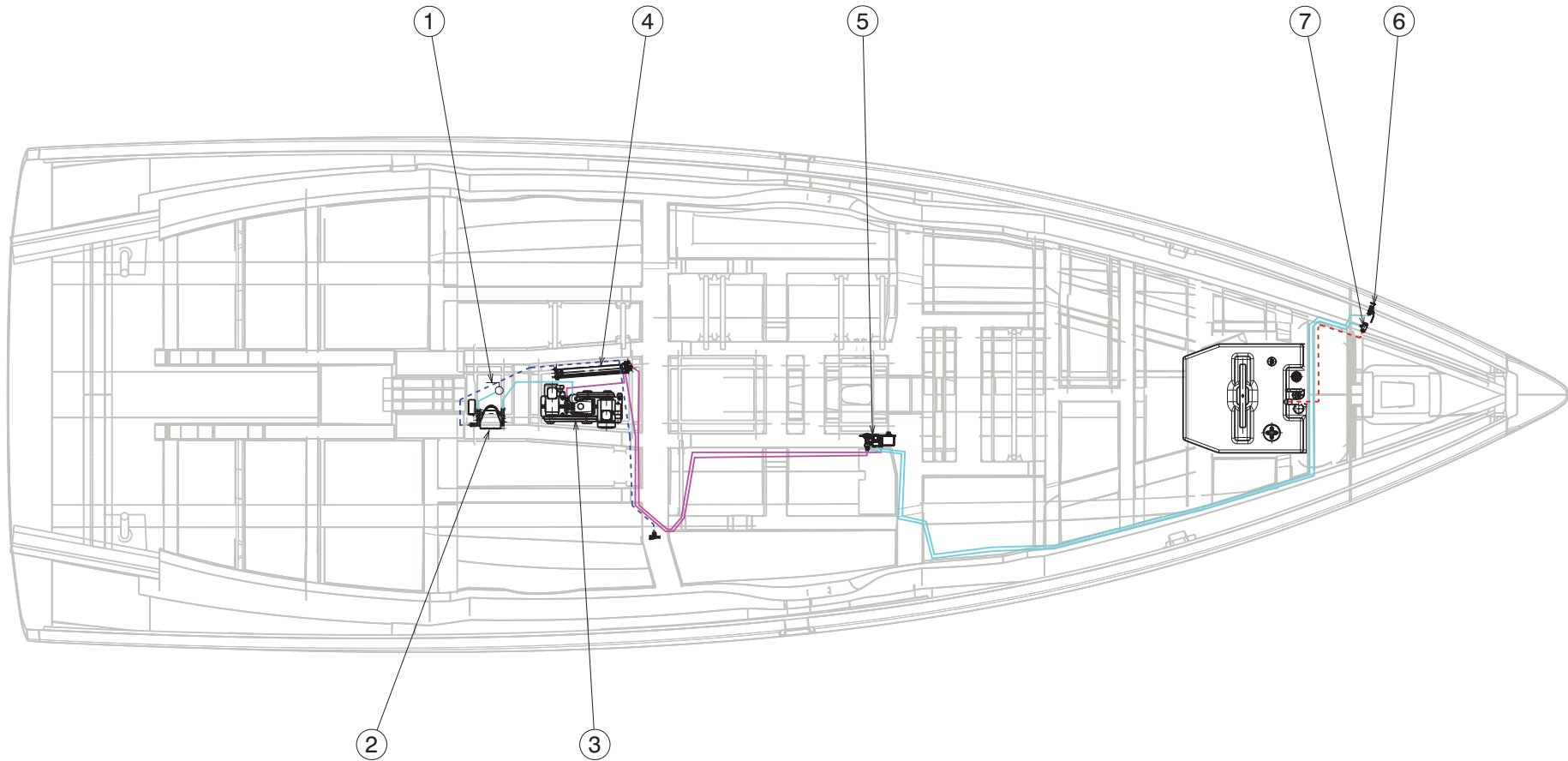

Reference	Designation
1	Seawater inlet
2	Seawater filter
3	Motor unit
4	Membranes
5	Control panel
6	Brine drainage
7	Connection to on-board water circuit

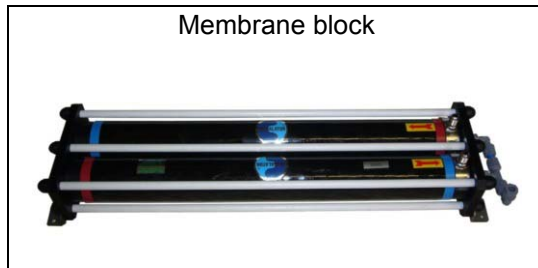
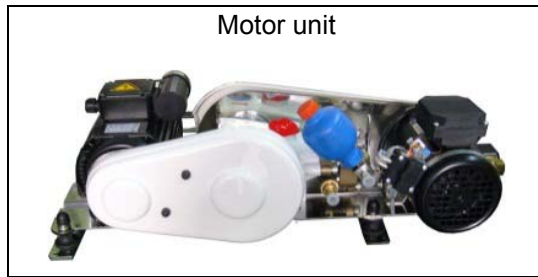

13.6 BLACKWATER SYSTEM (TOILET)





General points

- Blackwater is human waste including water flushed from the toilets.
- Close the valves after each use and especially when the boat is unattended.
- Regularly check the valves and thru-hull seacocks for proper operation and watertightness.
- Regularly check the tightness of the flexible pipe clamps and connections.

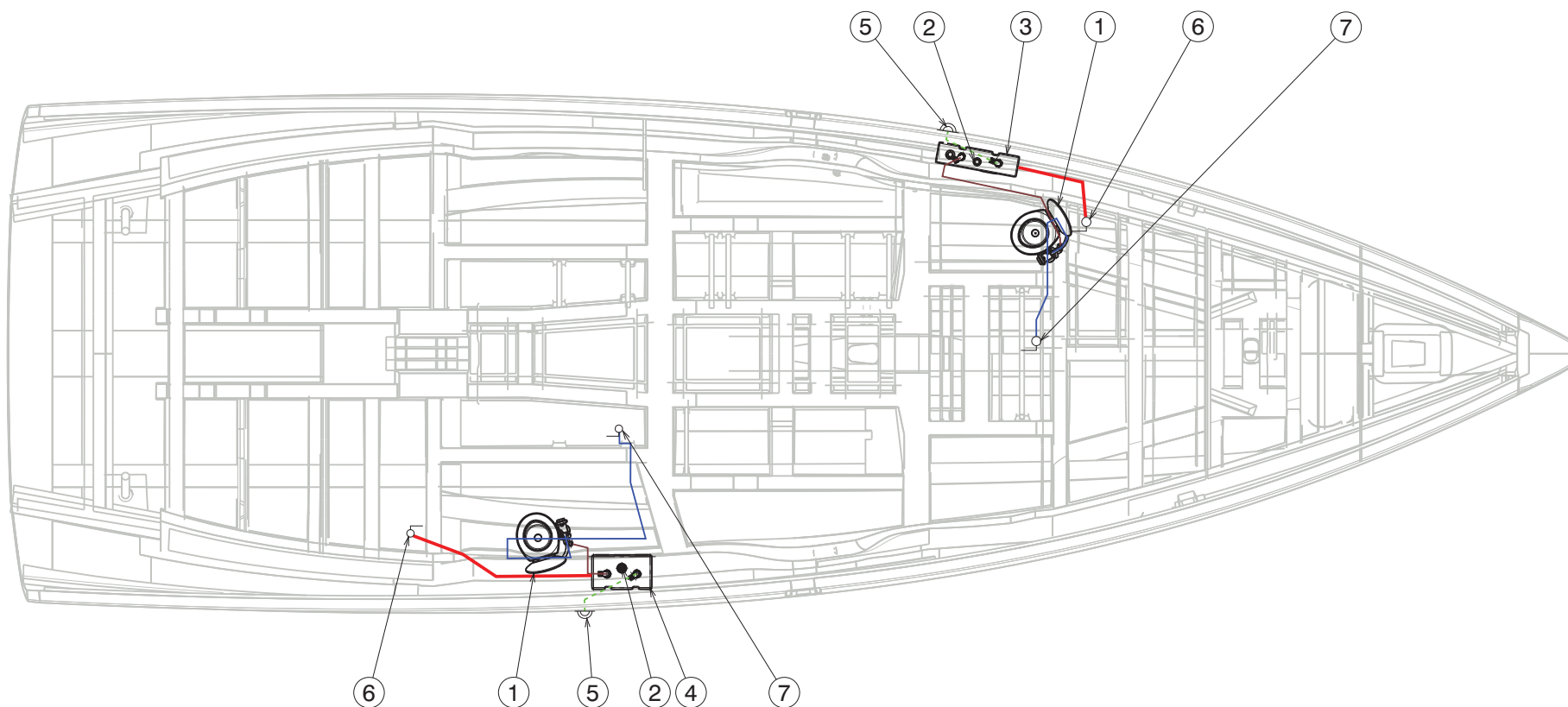
13.6.1 Diagram of blackwater system

MANUAL TOILET 3 cabins 2 heads version



	Seawater supply - 20mm diameter
	Vent pipe - 25mm diameter
	Suction hose - 38mm diameter
	Drainage hose - 50mm diameter

Reference	Designation
1	Manual toilet
2	Black water tank drainage cap (WASTE)
3	Blackwater tank (50L)
4	Blackwater tank (80L)
5	Blackwater tank vent
6	Black water tank drain through-hull
7	WC seawater intake

3 cabins 3 heads version

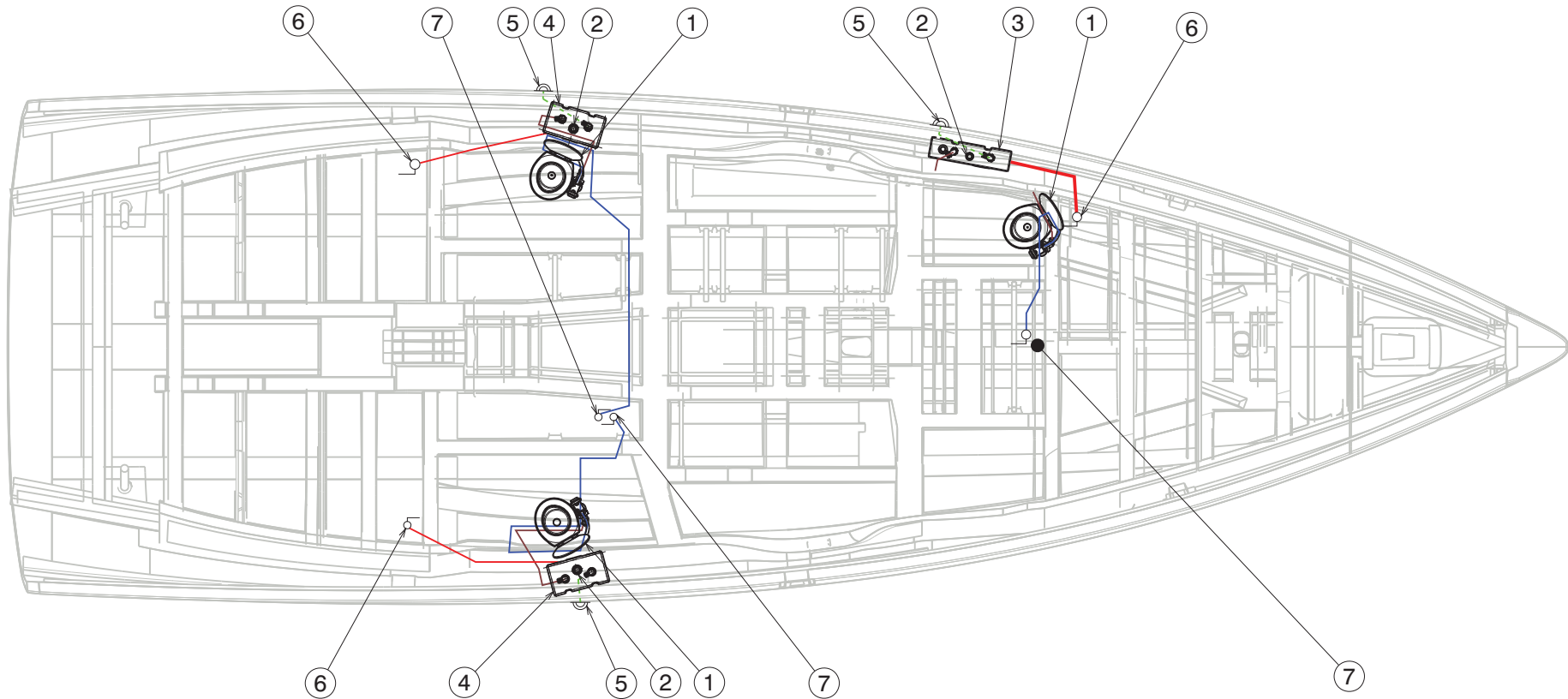



	Seawater supply - 20mm diameter
	Vent pipe - 25mm diameter
	Suction hose - 38mm diameter
	Drainage hose - 50mm diameter

Reference	Designation
1	Manual toilet
2	Black water tank drainage cap (WASTE)
3	Blackwater tank (50L)
4	Blackwater tank (80L)
5	Blackwater tank vent
6	Black water tank drain through-hull
7	WC seawater intake

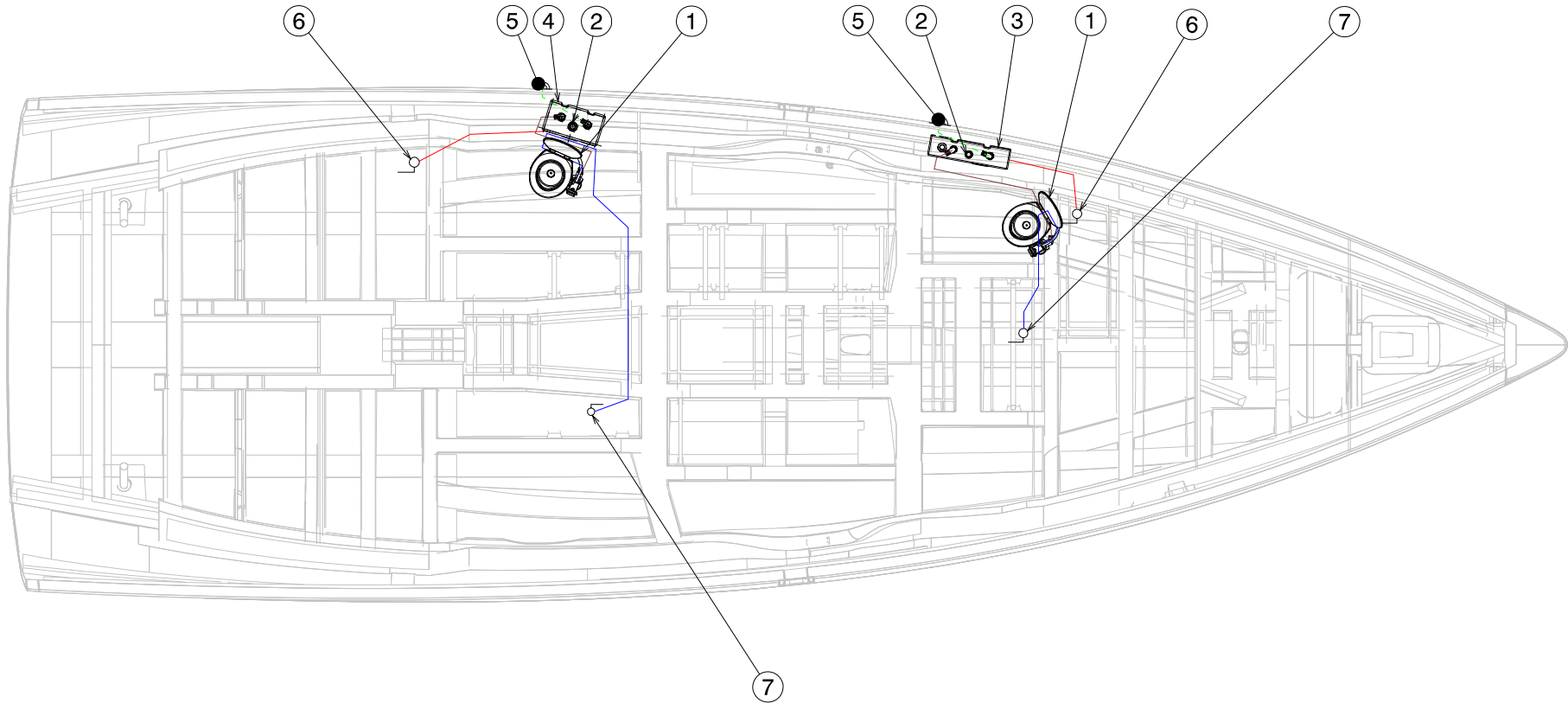
4 cabins 2 heads version



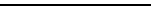

	Seawater supply - 20mm diameter
	Vent pipe - 25mm diameter
	Suction hose - 38mm diameter
	Drainage hose - 50mm diameter

Reference	Designation
1	Manual toilet
2	Black water tank drainage cap (WASTE)
3	Blackwater tank (50L)
4	Blackwater tank (80L)
5	Blackwater tank vent
6	Black water tank drain through-hull
7	WC seawater intake

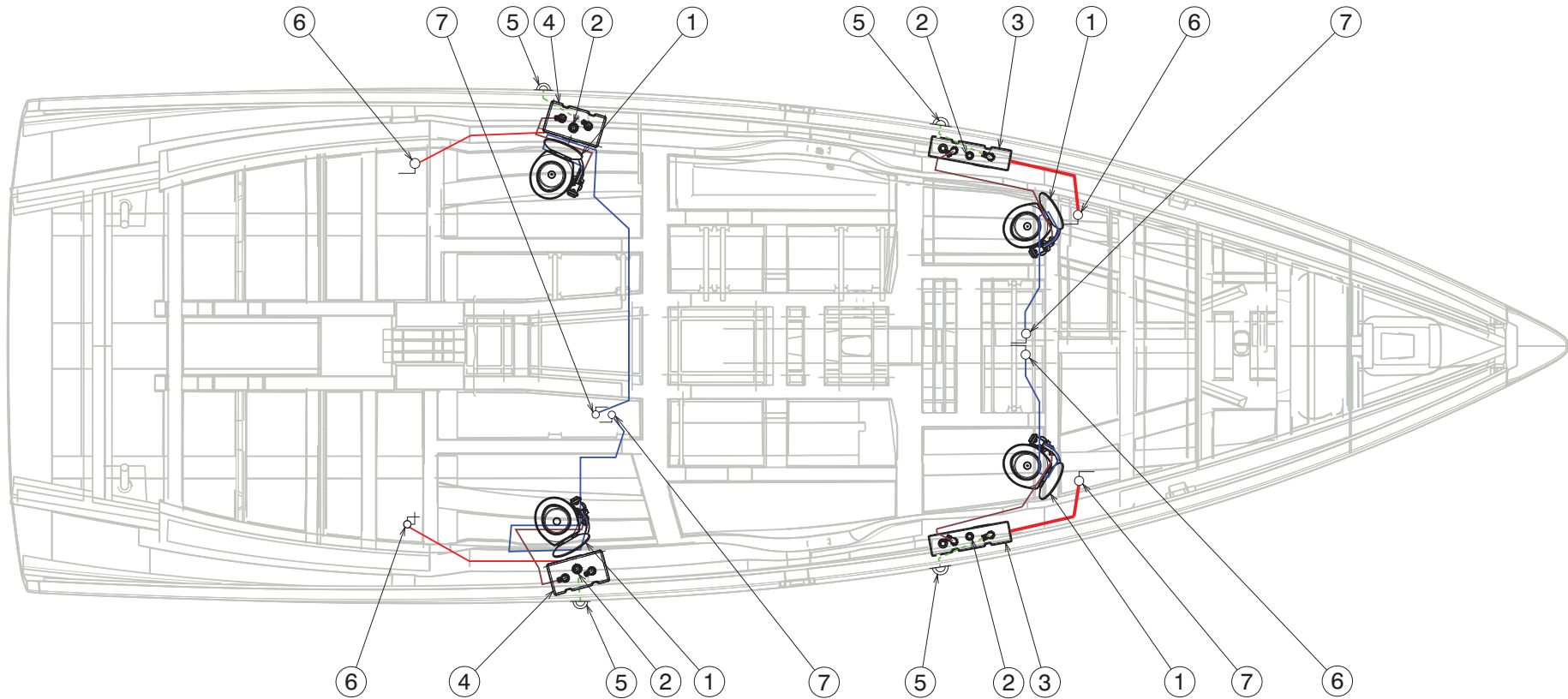
4 cabins 4 heads version



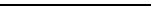

	Seawater supply - 20mm diameter
	Vent pipe - 25mm diameter
	Suction hose - 38mm diameter
	Drainage hose - 50mm diameter

Reference	Designation
1	Manual toilet
2	Black water tank drainage cap (WASTE)
3	Blackwater tank (50L)
4	Blackwater tank (80L)
5	Blackwater tank vent
6	Black water tank drain through-hull
7	WC seawater intake

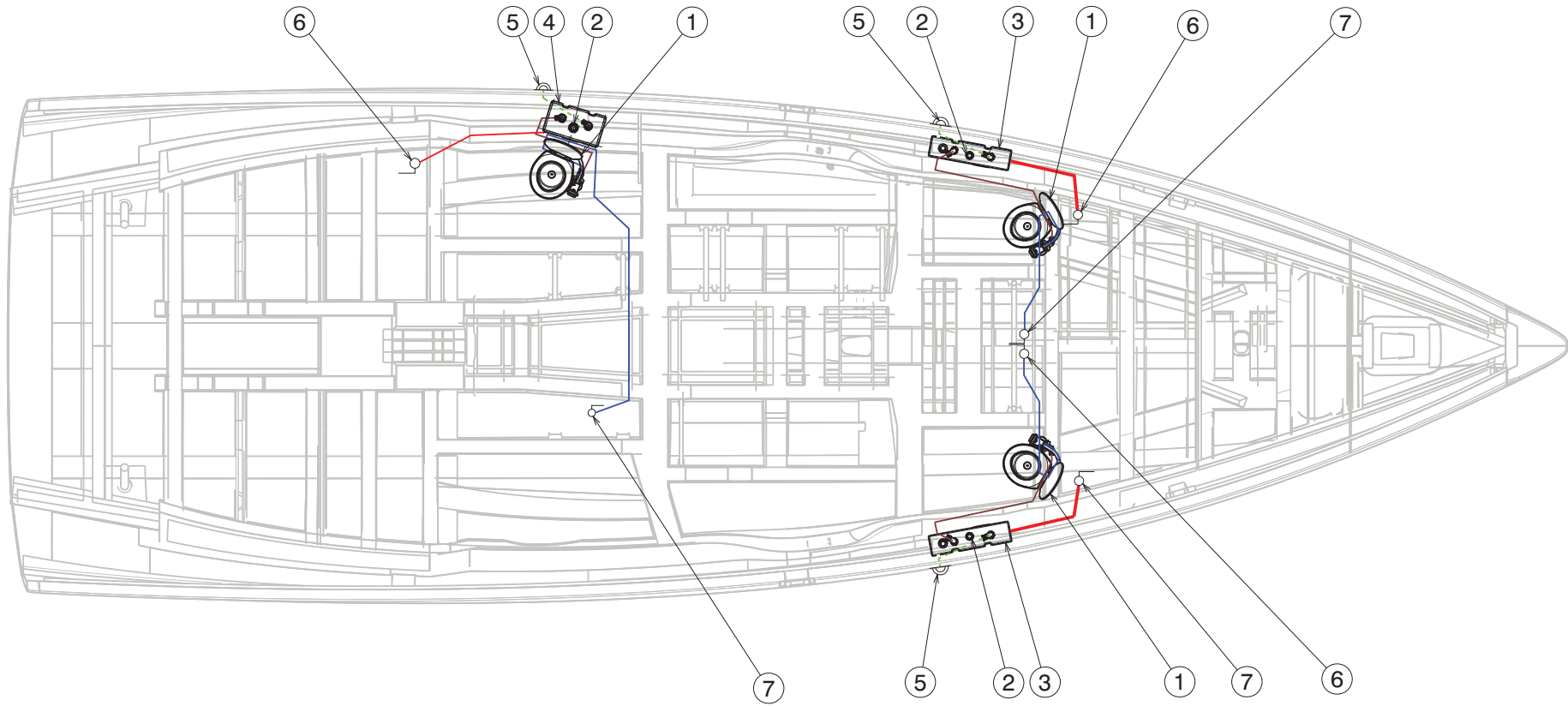
5 cabins 3 heads version

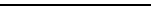

	Seawater supply - 20mm diameter
	Vent pipe - 25mm diameter
	Suction hose - 38mm diameter
	Drainage hose - 50mm diameter

Reference	Designation
1	Manual toilet
2	Black water tank drainage cap (WASTE)
3	Blackwater tank (50L)
4	Blackwater tank (80L)
5	Blackwater tank vent
6	Black water tank drain through-hull
7	WC seawater intake

ELECTRIC TOILET
3 cabins 2 heads version

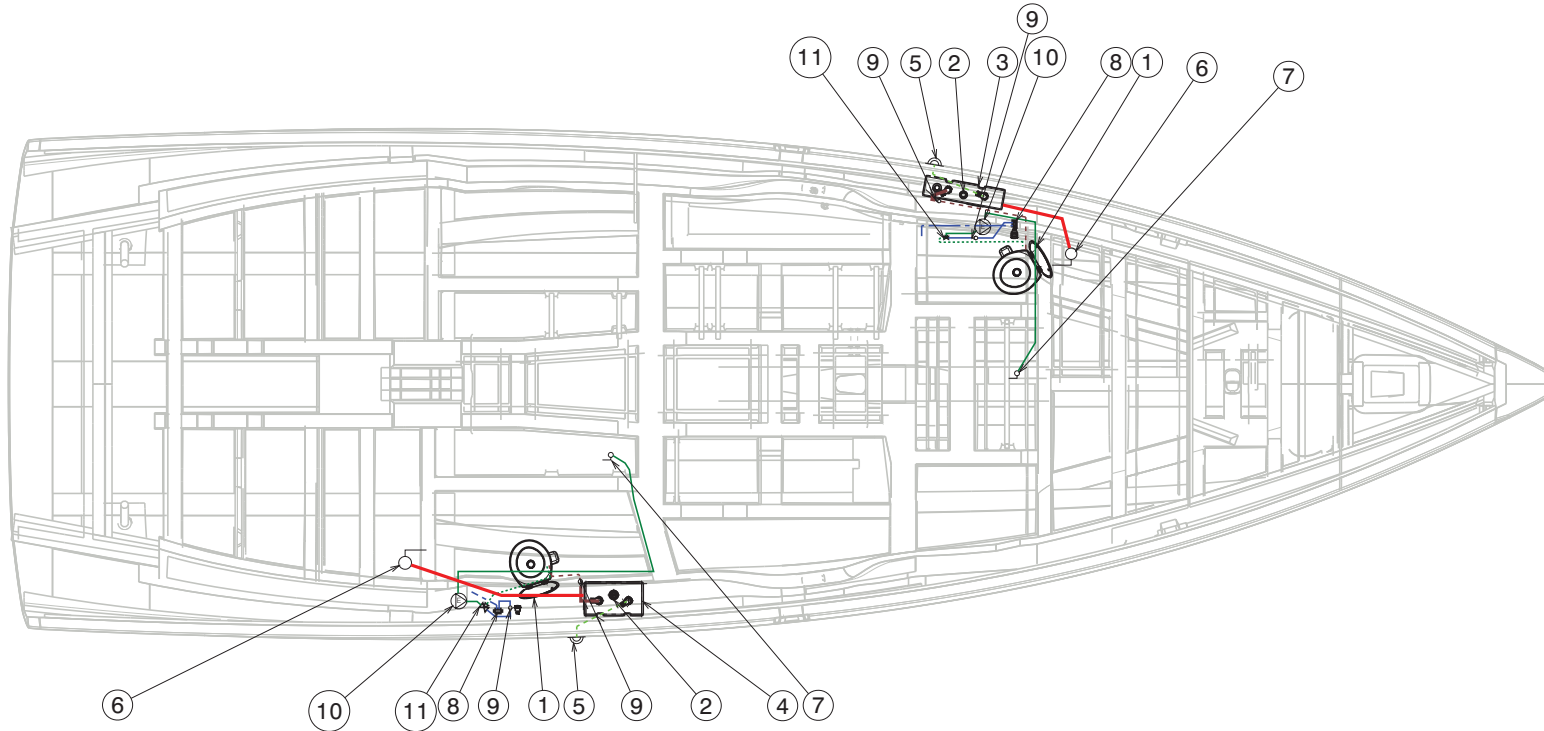







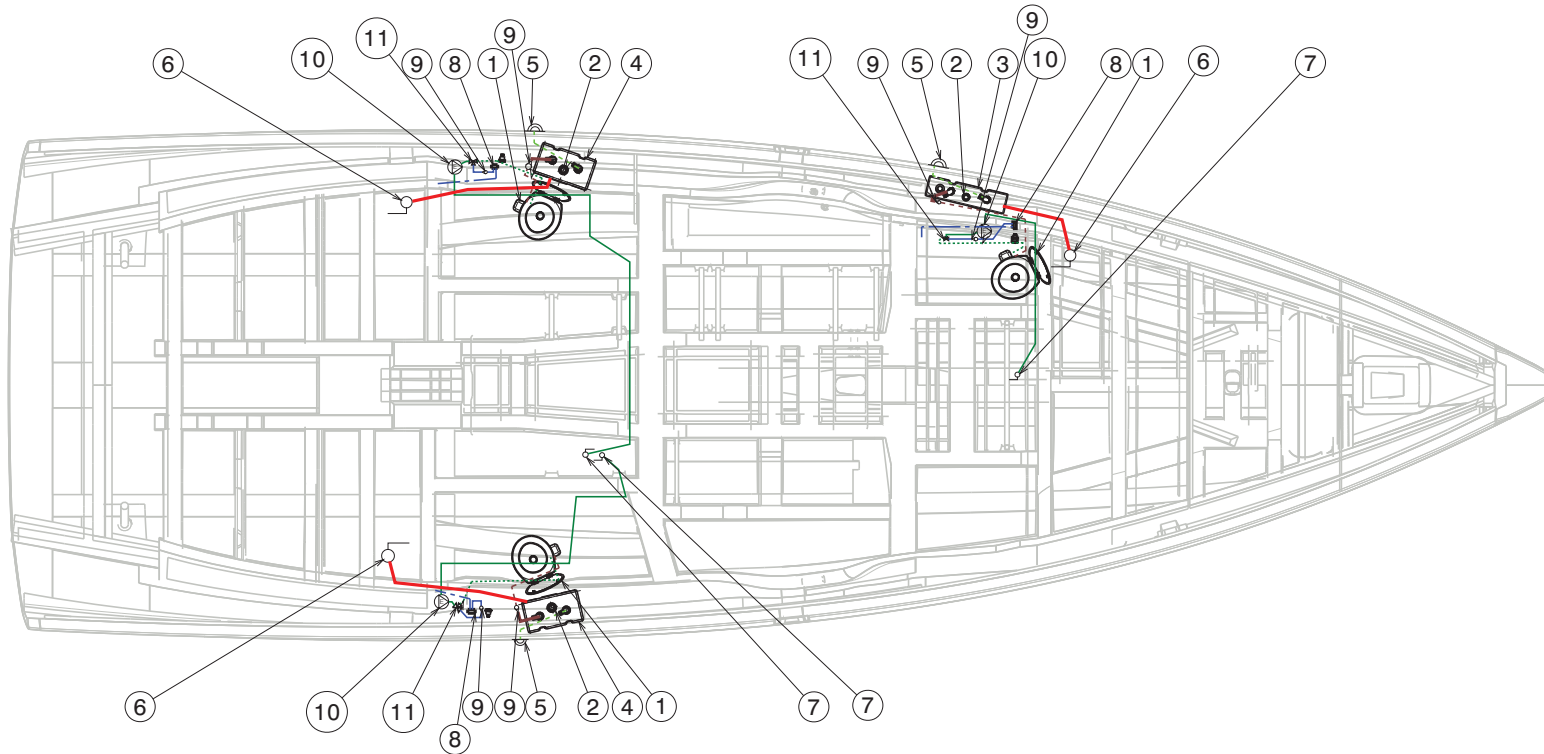

	Fresh water supply - 12mm diameter
	Fresh water supply - 19mm diameter
	Seawater supply - 20mm diameter
	WC supply - 20mm diameter
	Vent pipe - 25mm diameter
	Suction hose - 25mm diameter
	Suction hose - 38mm diameter
	Drainage hose - 50mm diameter

Reference	Designation
1	Electric toilet
2	Black water tank drainage cap (WASTE)
3	Blackwater tank (50L)
4	Blackwater tank (64L)
5	Blackwater tank vent
6	Black water tank drain through-hull
7	WC seawater intake
8	Electromagnetic valve
9	Non-return valve
10	Electric toilet pump
11	Connection

3 cabins 3 heads version



	Fresh water supply - 12mm diameter
	Fresh water supply - 19mm diameter
	Seawater supply - 20mm diameter
	WC supply - 20mm diameter
	Vent pipe - 25mm diameter
	Suction hose - 25mm diameter
	Suction hose - 38mm diameter
	Drainage hose - 50mm diameter

Reference	Designation
1	Electric toilet
2	Black water tank drainage cap (WASTE)
3	Blackwater tank (50L)
4	Blackwater tank (64L)
5	Blackwater tank vent
6	Black water tank drain through-hull
7	WC seawater intake
8	Electromagnetic valve
9	Non-return valve
10	Electric toilet pump
11	Connection

4 cabins 2 heads version

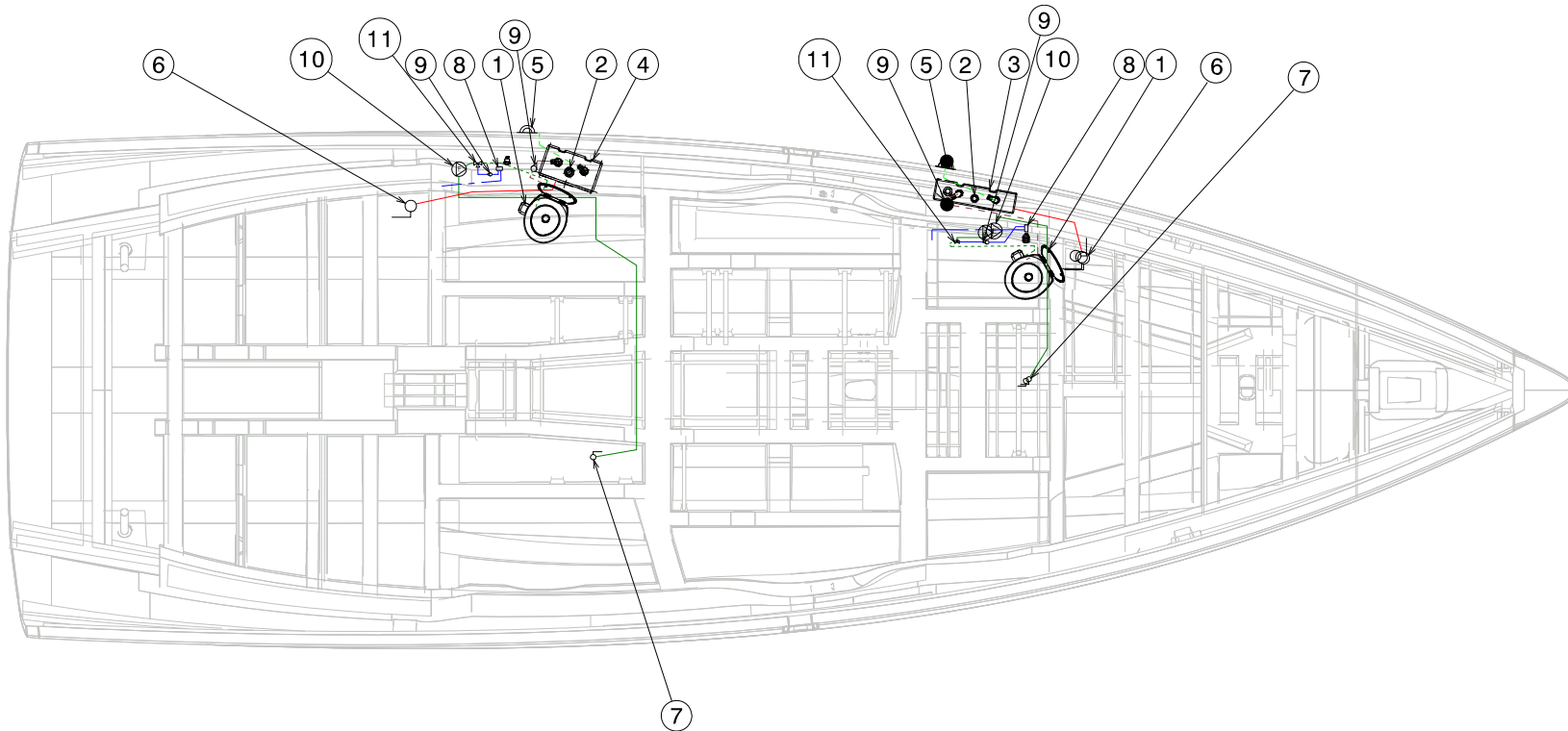

	Fresh water supply - 12mm diameter
	Fresh water supply - 19mm diameter
	Seawater supply - 20mm diameter
	WC supply - 20mm diameter
	Vent pipe - 25mm diameter
	Suction hose - 25mm diameter
	Suction hose - 38mm diameter
	Drainage hose - 50mm diameter

Reference	Designation
1	Electric toilet
2	Black water tank drainage cap (WASTE)
3	Blackwater tank (50L)
4	Blackwater tank (64L)
5	Blackwater tank vent
6	Black water tank drain through-hull
7	WC seawater intake
8	Electromagnetic valve
9	Non-return valve
10	Electric toilet pump
11	Connection

4 cabins 4 heads version

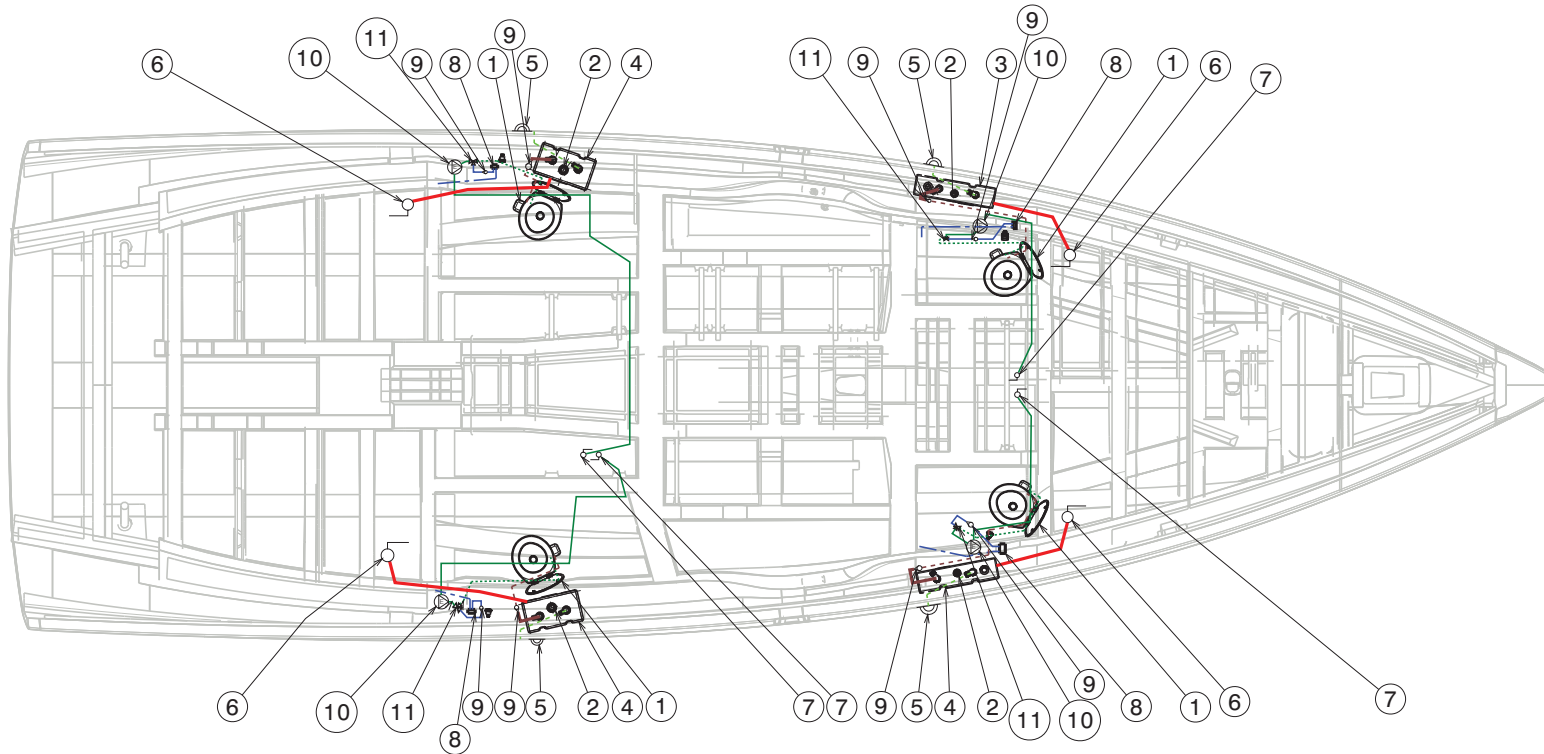

	Fresh water supply - 12mm diameter
	Fresh water supply - 19mm diameter
	Seawater supply - 20mm diameter
	WC supply - 20mm diameter
	Vent pipe - 25mm diameter
	Suction hose - 25mm diameter
	Suction hose - 38mm diameter
	Drainage hose - 50mm diameter

Reference	Designation
1	Electric toilet
2	Black water tank drainage cap (WASTE)
3	Blackwater tank (50L)
4	Blackwater tank (64L)
5	Blackwater tank vent
6	Black water tank drain through-hull
7	WC seawater intake
8	Electromagnetic valve
9	Non-return valve
10	Electric toilet pump
11	Connection

5 cabins 3 heads version

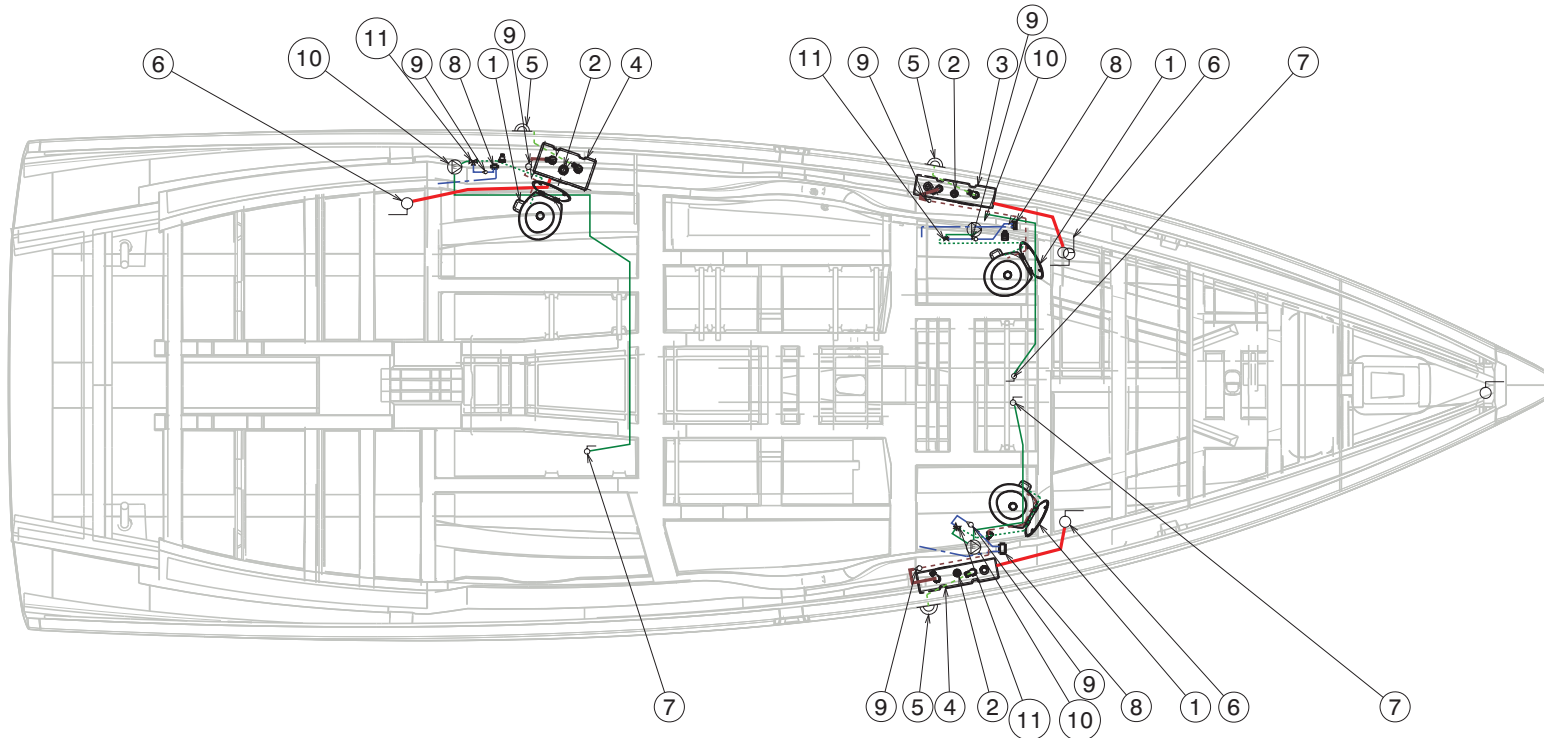

	Fresh water supply - 12mm diameter
	Fresh water supply - 19mm diameter
	Seawater supply - 20mm diameter
	WC supply - 20mm diameter
	Vent pipe - 25mm diameter
	Suction hose - 25mm diameter
	Suction hose - 38mm diameter
	Drainage hose - 50mm diameter

Reference	Designation
1	Electric toilet
2	Black water tank drainage cap (WASTE)
3	Blackwater tank (50L)
4	Blackwater tank (64L)
5	Blackwater tank vent
6	Black water tank drain through-hull
7	WC seawater intake
8	Electromagnetic valve
9	Non-return valve
10	Electric toilet pump
11	Connection

YOUR BOAT IS FITTED WITH A BLACKWATER TANK

To minimise odours from this tank, we suggest following the use and maintenance guidelines below:

1) Holding tank



- A blackwater tank is used solely for the temporary collection of water from the toilets.
- The tank can be emptied in 2 ways:
 - By connection to a pumping system that empties the tank by suction. This system uses the "WASTE" deck connection.
 - Via the thru-hull fitting, which empties directly into the sea (provided that the laws of the country in which the vessel sails permit dumping into the sea).
- Only use water-soluble toilet paper to avoid blockages.

Note: Sanitary towels and other items (paper handkerchiefs, dressings etc.) in the toilets and blackwater tank will result in blockages.

- Faecal matter causes the formation of unpleasant odours in the blackwater tanks, to which the use of salt water for flushing the toilets also contributes. Algae present in salt water also give off unpleasant odours.
- Completely empty the blackwater system before leaving the vessel unattended in temperatures below freezing.
- Ask for information about the laws in force in your country or your marina about discharging your waste waters into the sea.

2) Use of toilets

- Every time the toilets are used, flush afterwards with copious amounts of water in the bowl using the toilet pump (manual or electric).
- When you are leaving the boat for several days, flush with fresh water. You may wish to use the shower in the head for this purpose. Seawater allowed to stagnate in the bowl gives off bad odours.

3) Maintenance of blackwater tank

- The risk of unpleasant odours forming increases when the waste water remains in the tank for a long time.
- Whenever possible empty the tank regularly, even before it is full.
- Every time the tank is emptied put in about 5 litres of fresh water and add an appropriate detergent additive (available from chandleries). A very simple method is to add soda salts, which clean and disinfect at the same time.
- Before winterising, flush the tank with copious amounts of fresh water filling it through the 'WASTE' deck connection. Leave at least 5 litres of fresh water mixed with a detergent additive.
- Disinfecting: Disinfect the tank once a year by filling it with a solution of Javel water (1 to 1000).

4) Using the drainage valve

- The direct-to-sea drainage valve can be sealed by means of the drilled hole on the handle.
- To lock the drainage valve in the closed position: Pass the tightening collar around the drainage valve and feed through the hole in the handle as shown.

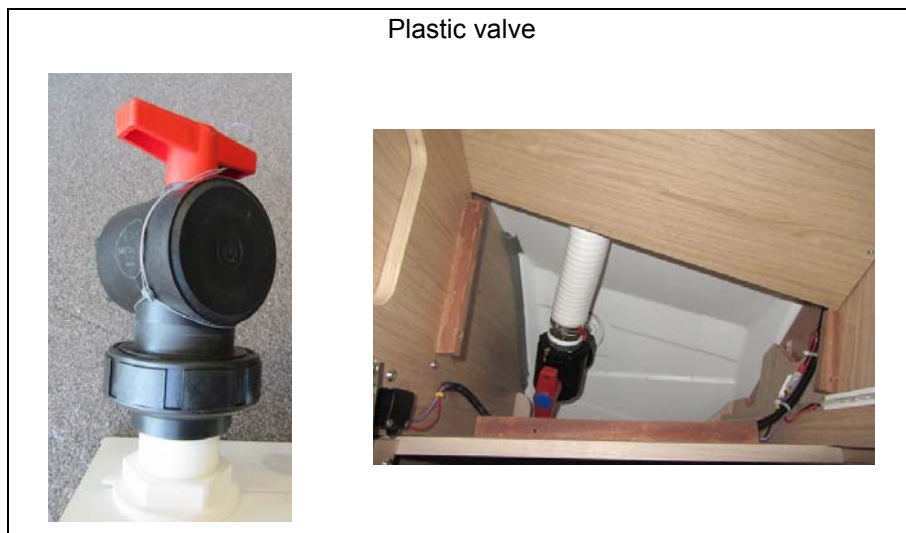

Never use automobile anti-freeze in the blackwater system: risk of poisoning.



Respect local regulations regarding the emptying of blackwater tanks.



- Beware of any unintentional draining.

Layout diagram of blackwater system

Emptying by gravity

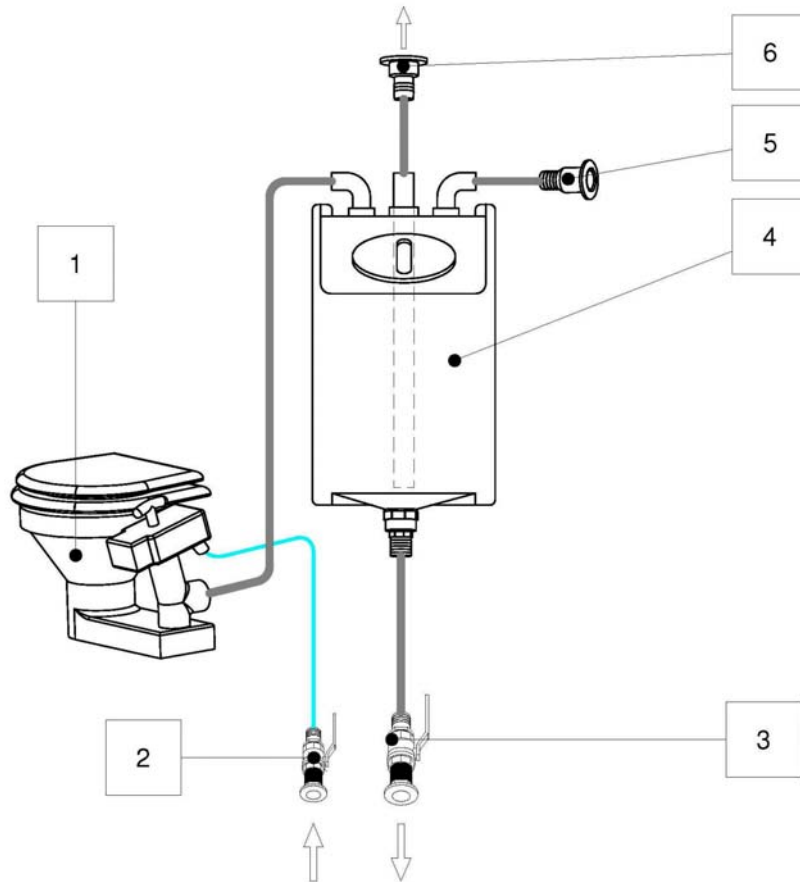

Reference	Designation
1	Toilet
2	Seawater intake valve
3	Thru-hull seacock
4	Blackwater tank
5	Vent
6	"WASTE" deck connection

Using a marine toilet fitted with a tank emptied by gravity

- I. Open the seawater intake valve (Ref 2).
- II. Fill the bowl by using the manual toilet pump.
- III. Using the toilet (Ref 1).
- IV.a. To empty the organic waste in the tank:
 - Make sure the thru-hull seacock (Ref 3) is closed.
 - Empty the bowl using the manual toilet pump.
- IV.b. For direct discharge into the sea:
 - Open the thru-hull seacock (Ref 3).
 - Empty the bowl using the manual toilet pump.
- IV.c. To discharge through the deck:
 - Open the deck connection marked "WASTE" (Ref 6).
 - Use the pump-out system where fitted at a port.



Refer to the manufacturer's instructions for use and maintenance.

Using an DC electric WC fitted with a tank emptied by gravity

I. Open the seawater intake valve (Ref 2).

II. Fill the bowl by pressing the fill button.

III. Using the toilet (Ref 1).

IV.a. To empty the organic waste in the tank:

- Make sure the thru-hull seacock (Ref 3) is closed.
- Empty the bowl by pressing the empty button.

IV.b. For direct discharge into the sea:

- Open the thru-hull seacock (Ref 3).
- Empty the bowl by pressing the empty button.

IV.c. To discharge through the deck:

- Open the deck connection marked "WASTE" (Ref 6).
- Use the pump-out system where fitted at a port.

Location of the solenoid valve: Port forward washroom

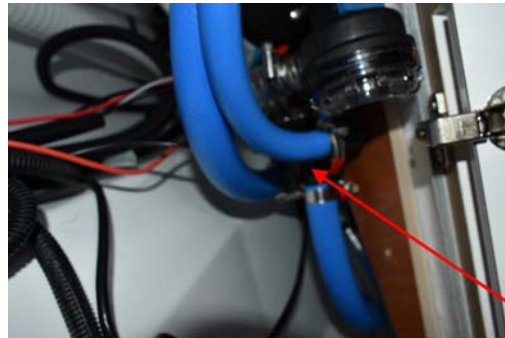

13.7 WASTE WATER SYSTEM

General points

- Waste water comprises the water coming from the sink, showers, air conditioning drains and washbasins.
- Close the valves after each use and especially when the boat is unattended.
- Regularly check the valves and thru-hull seacocks for proper operation and watertightness.
- Regularly check the tightness of the flexible pipe clamps and connections.



Observe local regulations regarding the emptying of greywater tanks.

LAYOUT OF COMPONENTS

Shower plug hole



Shower pump



Control



Shower screen





NOTE: It is essential that the shower screen remains locked in place when under way.

13.7.1 Diagram of waste water circuit installation

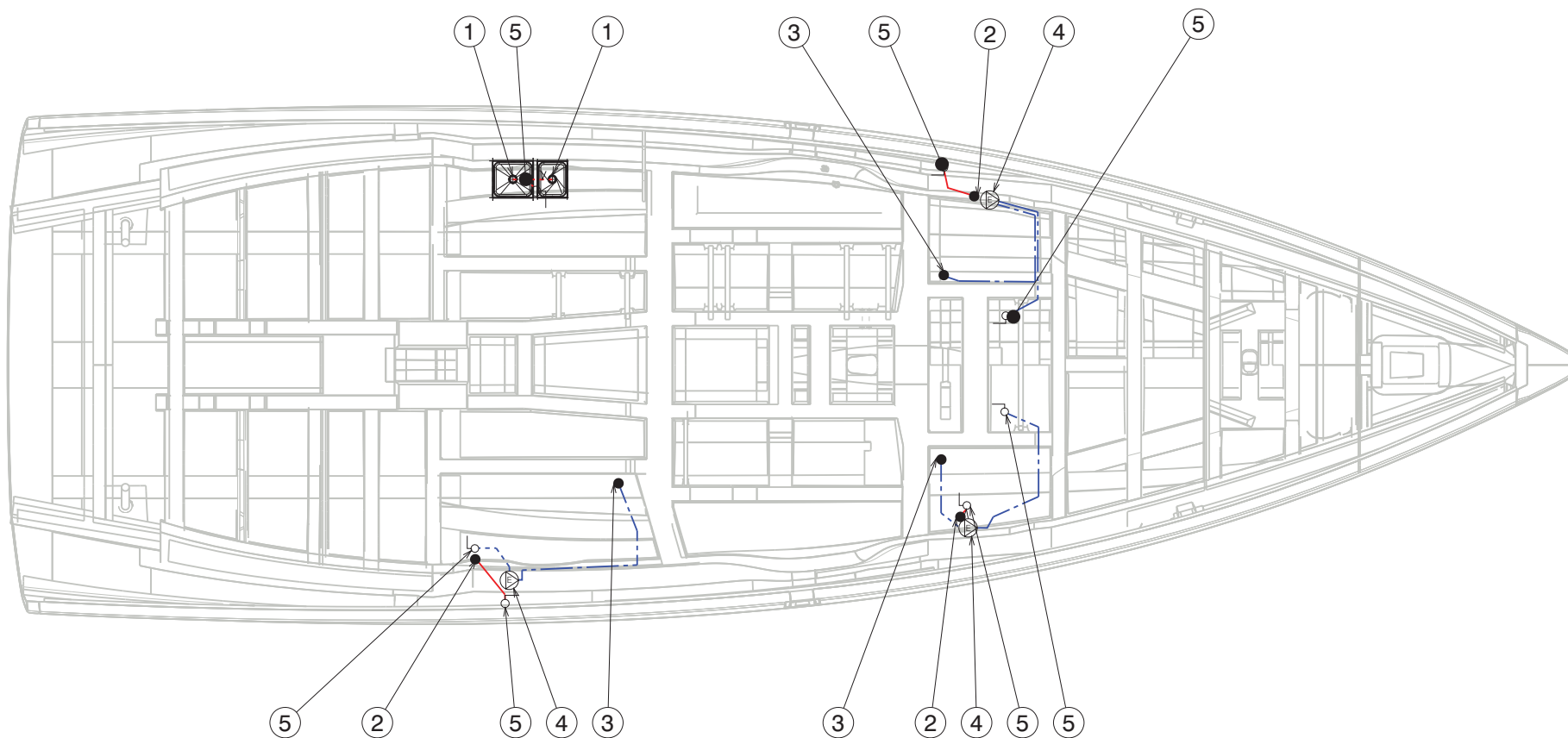
3 cabins 2 heads version





	Waste water pipe - 20mm diameter
	Waste water pipe - 25mm diameter
	Waste water pipe - 40mm diameter

Reference	Designation
1	Sink plug hole (Galley)
2	Washbasin drain plug (Head)
3	Shower plug hole
4	Shower pump drainage
5	Kitchen sink thru-hull drainage

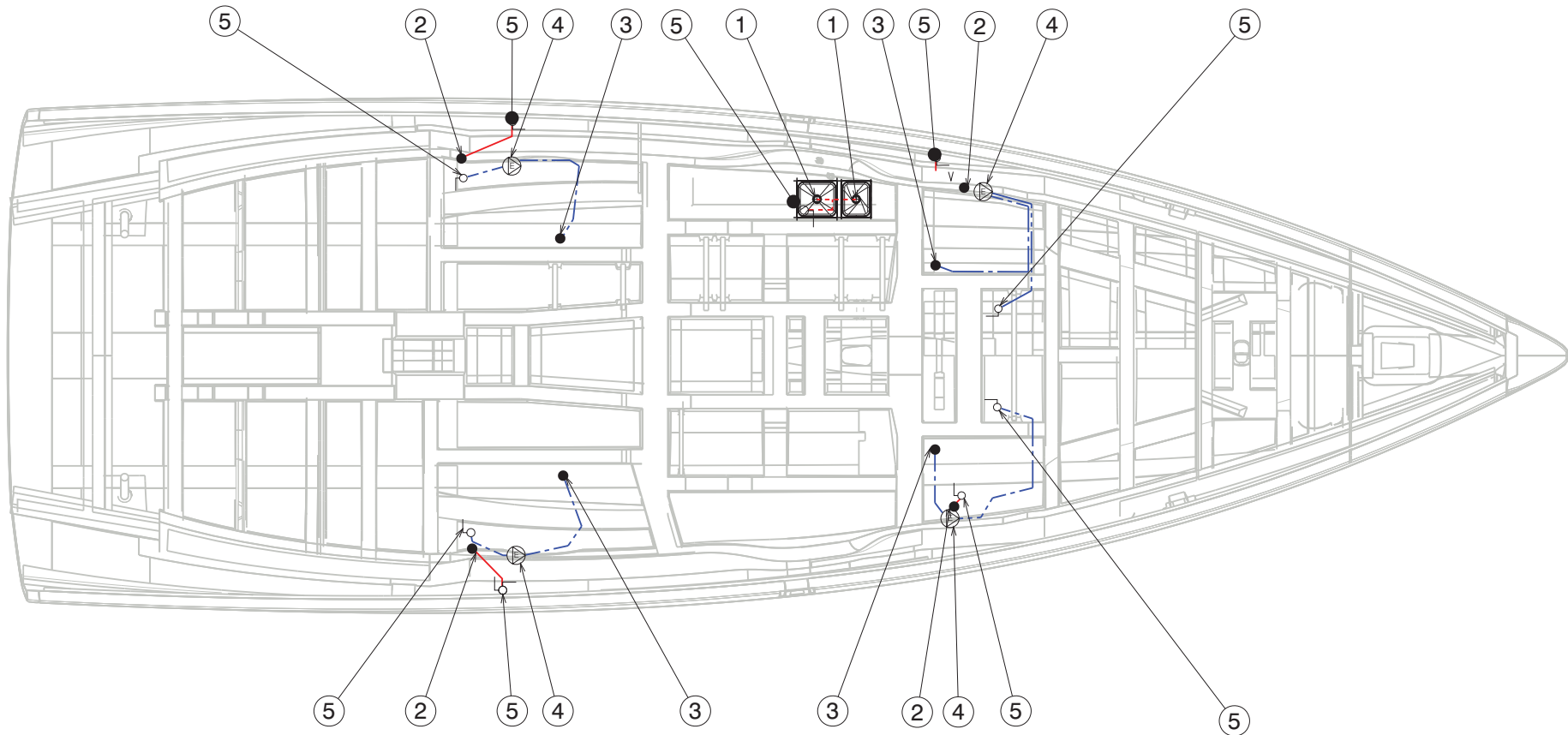
3 cabins 3 heads version





	Waste water pipe - 20mm diameter
	Waste water pipe - 25mm diameter
	Waste water pipe - 40mm diameter

Reference	Designation
1	Sink plug hole (Galley)
2	Washbasin drain plug (Head)
3	Shower plug hole
4	Shower pump drainage
5	Kitchen sink thru-hull drainage

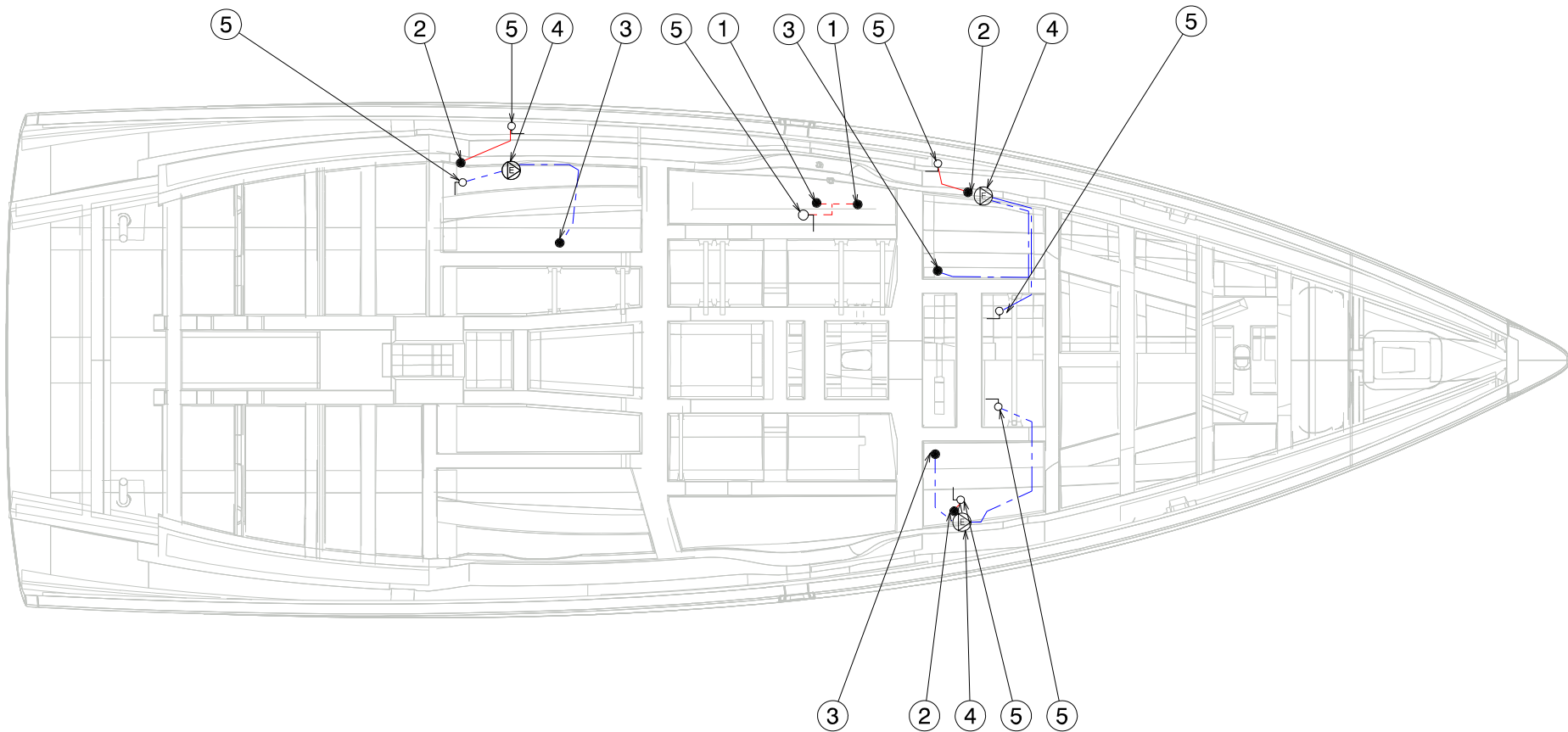
4 cabins 2 heads version



	Waste water pipe - 20mm diameter
	Waste water pipe - 25mm diameter
	Waste water pipe - 40mm diameter

Reference	Designation
1	Sink plug hole (Galley)
2	Washbasin drain plug (Head)
3	Shower plug hole
4	Shower pump drainage
5	Kitchen sink thru-hull drainage

4 cabins 4 heads version

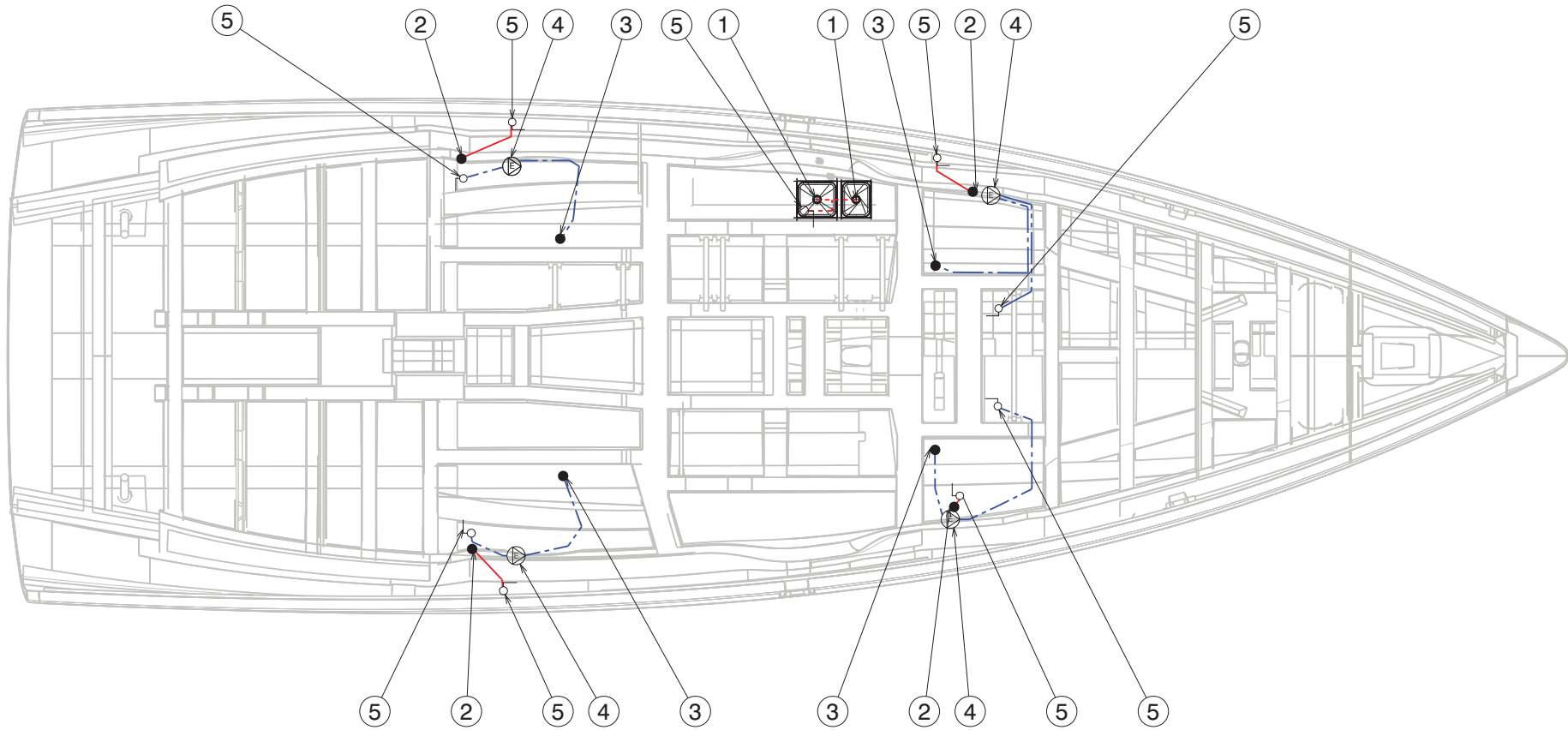



	Waste water pipe - 20mm diameter
	Waste water pipe - 25mm diameter
	Waste water pipe - 40mm diameter

Reference	Designation
1	Sink plug hole (Galley)
2	Washbasin drain plug (Head)
3	Shower plug hole
4	Shower pump drainage
5	Kitchen sink thru-hull drainage

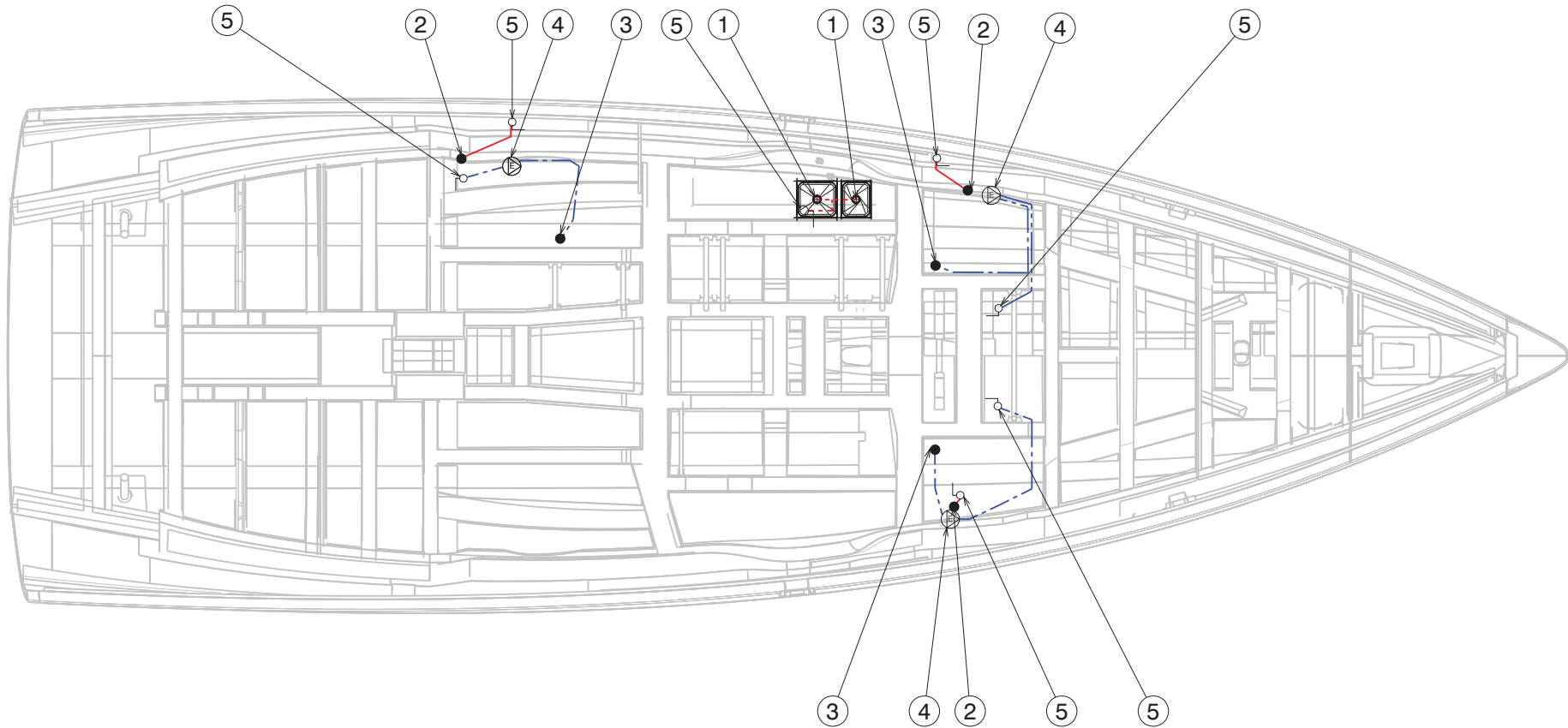
5 cabins 3 heads version



	Waste water pipe - 20mm diameter
	Waste water pipe - 25mm diameter
	Waste water pipe - 40mm diameter

Reference	Designation
1	Sink plug hole (Galley)
2	Washbasin drain plug (Head)
3	Shower plug hole
4	Shower pump drainage
5	Kitchen sink thru-hull drainage

ENGINE

■ Information relating to fire risks and risks of explosion	204
■ Danger from moving mechanical parts	205
■ General points	205
■ Starting the engine	208
■ Engine water intake valve.....	209
■ Anti-siphon valve.....	210
■ Fuel filter	211
■ Engine installation.....	212
■ Engine control	213
■ Access to the engine.....	214
■ Propeller	214

14.1 INFORMATION RELATING TO FIRE RISKS AND RISKS OF EXPLOSION

- Make sure that the coolant is circulating properly.
- Ensure that the engine compartment ventilation air inlets are kept clear.
- Stop the engine and refrain from smoking while the fuel tank is being filled.
- Have your fuel circuit checked regularly by a professional engineer.
- Avoid any contact between inflammable materials and the hot sections of the engine.
- Never switch off or cut off energy to the electric system when the engine is running.
- Never block access to the fuel supply valve.
- Do not obstruct or modify the ventilation system.
- Never turn the engine over when the boat is on land.
- Fuel stored outside the tanks (jerrycans, portable fuel tanks, etc.) must be stowed on deck and protected from bad weather and mechanical damage.
- Regularly check that the engine compartment is clean and dry.

Engine water intake valve:
Located directly on the saildrive



Fuel supply valve:
located directly on the tank



14.2 DANGER FROM MOVING MECHANICAL PARTS

- Keep away from the drive shafts and the mechanical parts of the engine when they are in motion (including belts, moving parts and hot components).
- Be careful if you have long hair, bulky clothing, rings etc. (these may become caught).

14.3 GENERAL POINTS

- Do not install an engine more powerful or heavier than recommended for this boat, since doing so may compromise the boat's stability.
- Any alteration or modification to the exhaust system of the propulsion engine(s) is prohibited.
- Make sure you have enough fuel before sailing.
- Stop the engine before opening the engine compartment.
- Do not close the fuel supply valve between each use of the engine (except in the event of prolonged disuse).
- Get the whole propulsion system checked at least once a year by a professional engineer.

see Chapter: MANOEUVRABILITY.

Always start the engine with the control lever in neutral.

Type of motorisation

Your vessel is fitted with an in-board diesel engine.

Transmission type is: Sail-drive



- Regularly check that the O ring on the filler cap is in good condition to prevent water ingress.
- Keep the fuel tank as full as possible to prevent condensation.
- Be careful with any possible risk of oil and fuel spillage.
- Follow the engine manufacturer's instructions exactly.
- **Never switch off the battery isolators when the boat's engine is running (risk of serious damage to the charging circuit).**

Filling up with fuel

- Fill the fuel tank by opening the cap marked "DIESEL", provided for this.

NOTE: Ensure the seal is tightly closed to prevent ingress of water.

- Regularly check that the O ring on the filler cap is in good condition to prevent water ingress.
- The generator has its own fuel supply valve.

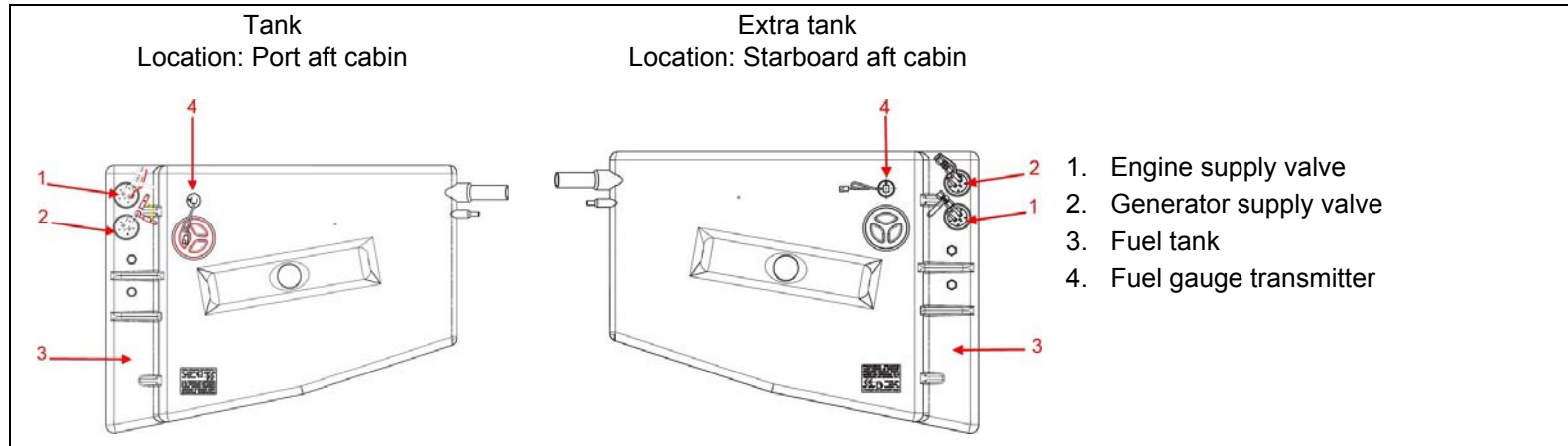



Tank selection

- A pull control enables you to select which fuel tank to use to supply the engine.
 - Lever pushed: fuel supply from the port tank.
 - Lever pulled: fuel supply from the starboard tank.

Gauge

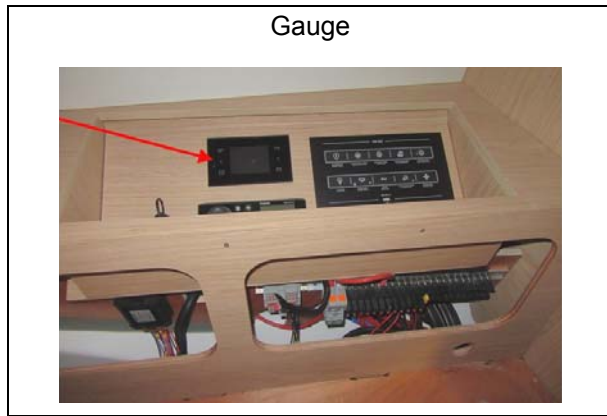
- The fuel level is transmitted via the gauge to the indicator on the steering station (Touch screen).



 The tanks' nominal capacity cannot be fully used due to the load and the need to maintain the correct trim. A 20% reserve should be kept.

14.4 STARTING THE ENGINE

Before starting the engine, it is essential:

- to open the fuel supply valve;
- to open the seawater intake valve of the engine;
- to switch on the battery supply by using the battery isolator switches;
- to put the control lever in neutral.

Make a habit of looking to see if seawater is pumped out with the exhaust gases as soon as you start the engine. If no water runs out, stop the engine immediately. Check the coolant flow.

The engine compartment bilge fan is activated automatically when the engine is started.



Before using the engine, make sure you carefully read the handbook provided by the engine manufacturer.



- Always start the engine with the control lever in neutral.
- Learn how to judge the necessary distance of deceleration for the vessel to come to a complete stop (the reverse gear is not a brake).

14.5 ENGINE WATER INTAKE VALVE

The seawater intake valve plays a crucial role in ensuring that the engine runs well.

- Keep the filter under the hull as clean as possible;
- Brush the filter whenever the boat is lifted out.

This valve must absolutely always be opened before starting the engine.

A seawater filter filters the water before it goes through the heat exchanger.

Regularly inspect the seawater filter and clean it if necessary. Screw/unscrew the cover of the filter by hand (never use tools).

For lengthy absences, close the engine's seawater intake valve.

Seawater intake



Seawater filter



14.6 ANTI-SIPHON VALVE

- The function of the anti-siphon valve is to inhibit the siphoning action when the engine stops, thus preventing a backflow of water.
- It is possible that on starting the engine or at certain engine speeds some drops of water may be seen escaping from the anti-siphon valve. If this occurs, you must clean the anti-siphon valve: dismantle the water collector at the top of the anti-siphon valve, then clean the valve with fresh water to remove any impurities.
- Then do the reverse procedure to refit the cleaned component, taking care not to refit the valve the wrong way round.
- It is advisable to carry out this simple preventative maintenance procedure on the anti-siphon valve once a year.

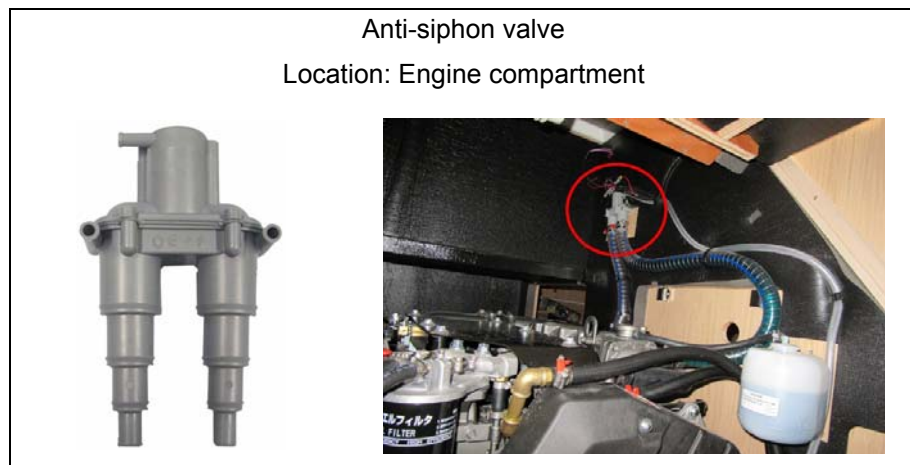

14.7 FUEL FILTER

Engine running problems may stem from various causes, including dirty fuel. The injection pump may wear out if there is water in the system. The water results either from condensation resulting from an insufficiently filled tank, or from a filler cap which has either not been closed properly or which has a damaged seal.

In order to prevent any water infiltration, the fuel runs through two filters:

- One filter is an integral part of the engine; its role is to filter fuel very finely. Please refer to the engine manufacturer's notes for any maintenance and for the frequency of filter changes.
- The second filter is on the pipe that links the tank to the engine; it works as a water decanter and prefilter.

Maintenance

- Purge the impurities by unscrewing the screw located at the base of the decanting bowl (without removing it). Let the liquid run into a receptacle until the fuel runs clear. Do this several times a year.
- Change the pre-filter at least once a year.

Location: Engine compartment



14.8 ENGINE INSTALLATION

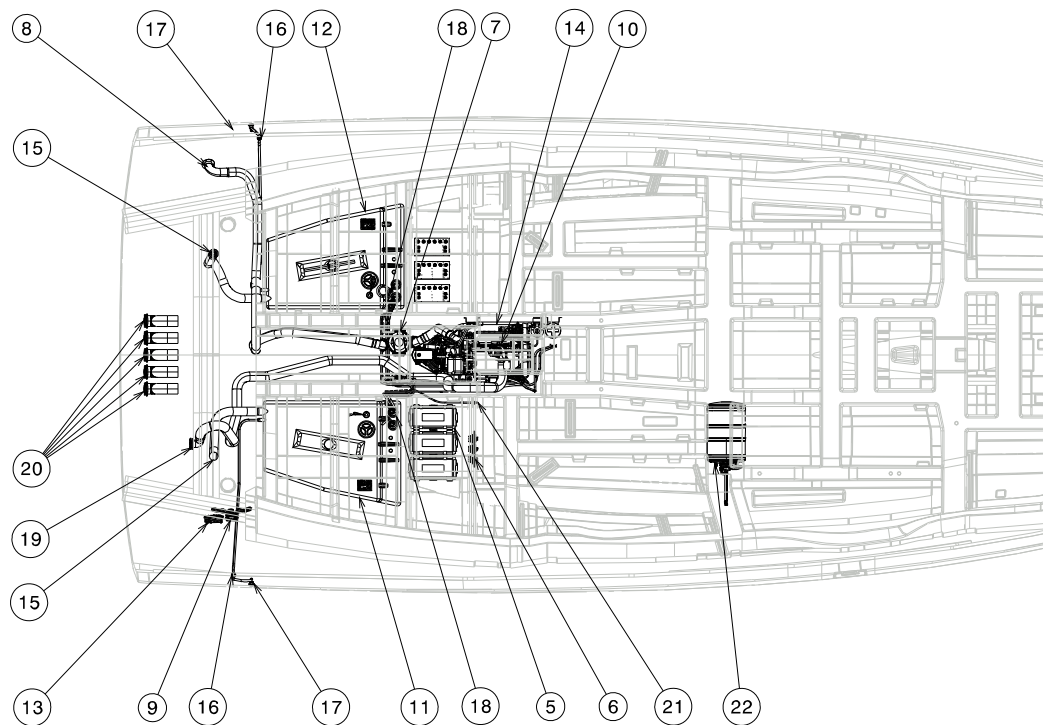
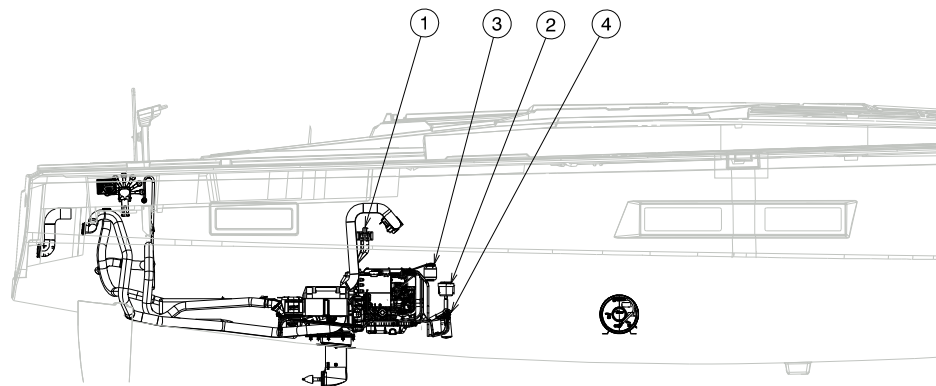

Reference	Designation
1	Anti-siphon valve
2	Seawater filter
3	Expansion tank
4	Fuel filter
5	Engine battery
6	Engine battery switch
7	Water trap
8	Engine exhaust
9	Engine control lever
10	Engine compartment ventilator
11	Auxiliary fuel tank
12	Fuel tank
13	Engine instrument panel
14	Motor
15	Fuel filler (DIESEL)
16	Non-return valve
17	Fuel tank vent
18	Hot air outlet
19	Fresh air intake
20	Tank selection pull
21	Water heater

Sail Drive engine installation



14.9 ENGINE CONTROL

- The engine manufacturer's notes provide detailed explanations on how to operate the engine and keep it running well.
- Read the manufacturer's notes on use and maintenance of the engine.

Control lever

- The control lever is fitted with a safety system which prevents the engine from starting when in gear.

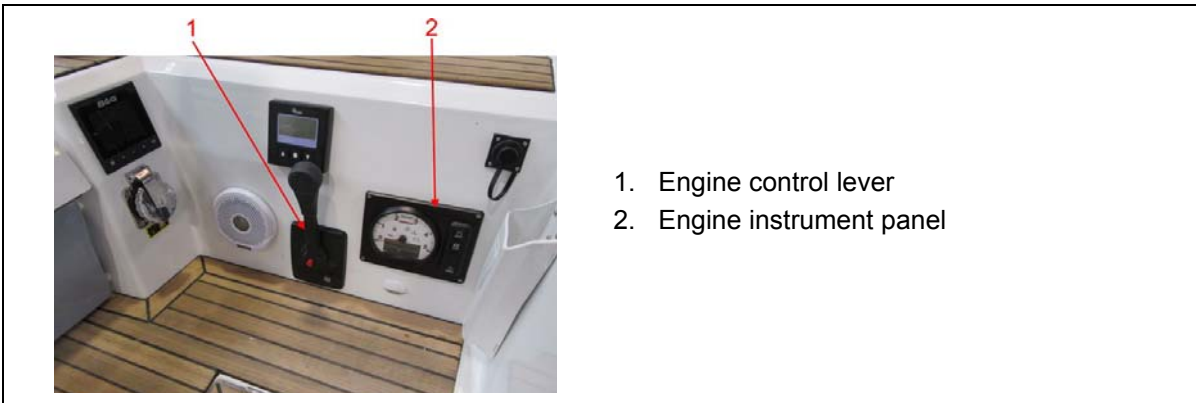

1. Engine control lever
2. Engine instrument panel

14.10 ACCESS TO THE ENGINE

Access to the engine can be gained via:

- Side hatches,
- The companionway.

All access hatches to the must strictly be kept shut when at sea.

14.11 PROPELLER

- The propeller delivered with the boat is specifically selected after trials carried out in collaboration with the engine manufacturer. Never change the propeller without first consulting a professional engineer.
- Propeller efficiency will drop if the propeller blades are damaged or dirty: clean the blades regularly and attentively.
- During lift-out, check the propeller: it should turn freely on its axis and there should be no play.
- Single-engine boats are equipped with a right-hand propeller.



- Respect speed limits.
- If this boat is equipped with a fixed blade propeller, when sailing at speeds over 8 knots it is essential to leave the reverse gear control in neutral.

STEERING SYSTEM

■ General points	216
■ Diagram of layout	217
■ Bow thruster & stern thruster (retractable).....	220

15.1 GENERAL POINTS

- The steering operates by steering cables.
- The steering system is an important safety feature. For this reason, an annual inspection of the whole system must be carried out by a professional engineer.
- Regularly check the tension of the steering cables and the tightness of the steering components. If needed, adjust the tension of the steering cables. Don't tighten the steering cables excessively. When properly adjusted the steering should work smoothly, with no play at all and no stiffness in the tiller or wheel (consult your dealer).
- Do not grease the steering cables or the pulleys.
- Maintain the nylon, ertalon or teflon bushes with only a suitable lubricant.
- Each ring is a wearing part: make sure you change them regularly (Please contact your dealer).



The textile lines on the boat have a lifetime of 5 years. Beyond 5 years (the expiry date is sewn on the textile lines) the textile lines must be changed.

Access: Cockpit locker



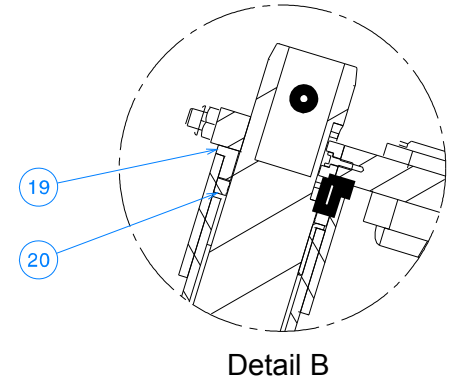
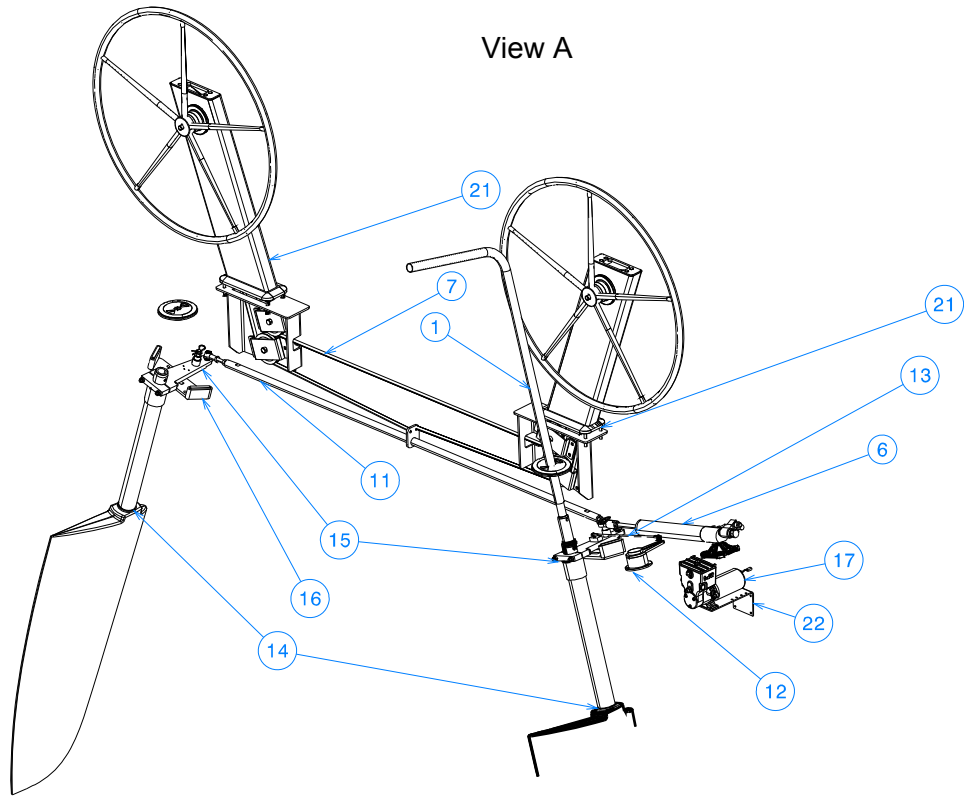
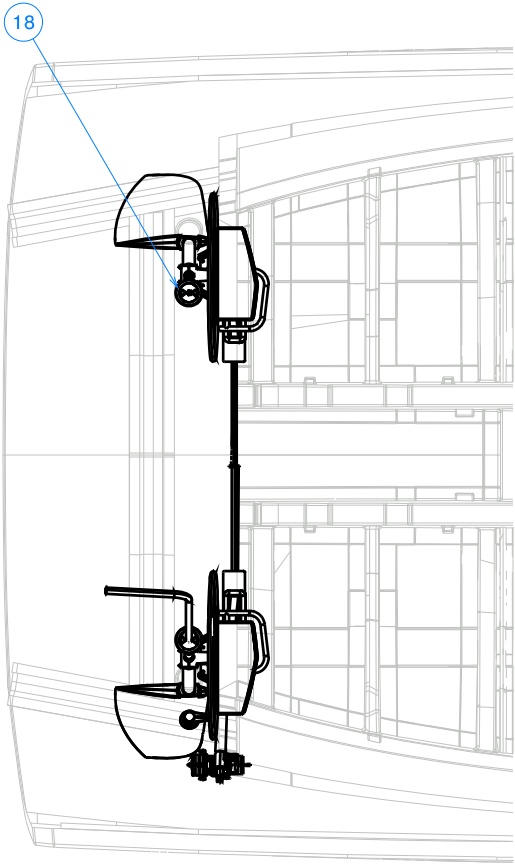

Reference	Designation
1	Emergency tiller
2	Steering wheel
3	Rudder
4	Rudder stock
5	Rudder tube
6	Hydraulic piston
7	Textile line
8	Port sheave support
9	Sheave
10	Starboard sheave support
11	Connecting rod
12	Rudder (Tiller angle indicator)
13	Thread stalk
14	Balance bush
15	Stock arm
16	Stock arm stop
17	Hydraulic unit (Autopilot)
18	Inspection hatch
19	Flanged bush
20	Seal
21	Wheel column
22	Hydraulic unit mounting

15.3 BOW THRUSTER & STERN THRUSTER (retractable)

General points

- The thruster motor is DC powered.
- The thruster is a steering aid for manoeuvres at low speed (e.g. picking up a mooring buoy or berthing on a pontoon). The bow thruster must only be used at speeds of less than 2 knots.
- An operating relay is installed in the circuit.
- A fuse protects the electrical circuit.
- The thruster motor has its own battery bank.

Operation

- Before starting the thruster, make sure no swimmers, floating objects or ropes are near the boat.
- Make sure the boat is stationary (with no drift) before deploying and retracting the propeller.
- Turn on the bow thruster battery switches.
- The engine's positive battery isolator automatically switches on and off when the engine is started/stopped. The thruster circuit negative is connected to the boat's general negative.
- The bow-thruster motor must operate with the boat's engine running.
- A control panel is located in the cockpit.
- Press both ON buttons simultaneously to start the thruster.
- Press the OFF button to switch off the thruster.

NOTE: It is important to switch off the thruster BEFORE switching off the boat's propulsion engine so that the thruster hatch can close.



- Refer to the manufacturer's instructions for use and maintenance.
- Never run the motor when the propeller is out of the water.
- With dual control, be careful to use only one control at a time.
- The motor must not run for longer than 3 minutes (risk of overheating).



- If the thruster hatch remains stuck in the lowered position, sail at reduced speed to the nearest port or harbour.
- Never attempt to close the hatch manually. Doing so may result in serious injury.
- Once in a safe place, consult a professional to reclose the thruster hatch.

Maintenance

- The bow thruster's motor:
 - is lubricated for life and the oil does not require draining;
 - must not be dismantled, even partially;
 - must be coated in antifoul to protect it from marine vegetation.
- Regularly check the charge state of the motor's batteries: a loss of voltage will cause premature wearing of the motor's relay contacts and brushes.

During lift-out

- Check that the propellers turn properly, with neither play nor stiffness.
- Clean the blades carefully.
- Remove the propeller, clean the shaft support and coat the shaft with silicone-based grease before refitting the propeller.
- After cleaning and applying a primer, antifoul the housing and the propellers.
- Change the thruster anode at least once a year (see Chapter: ANODES).



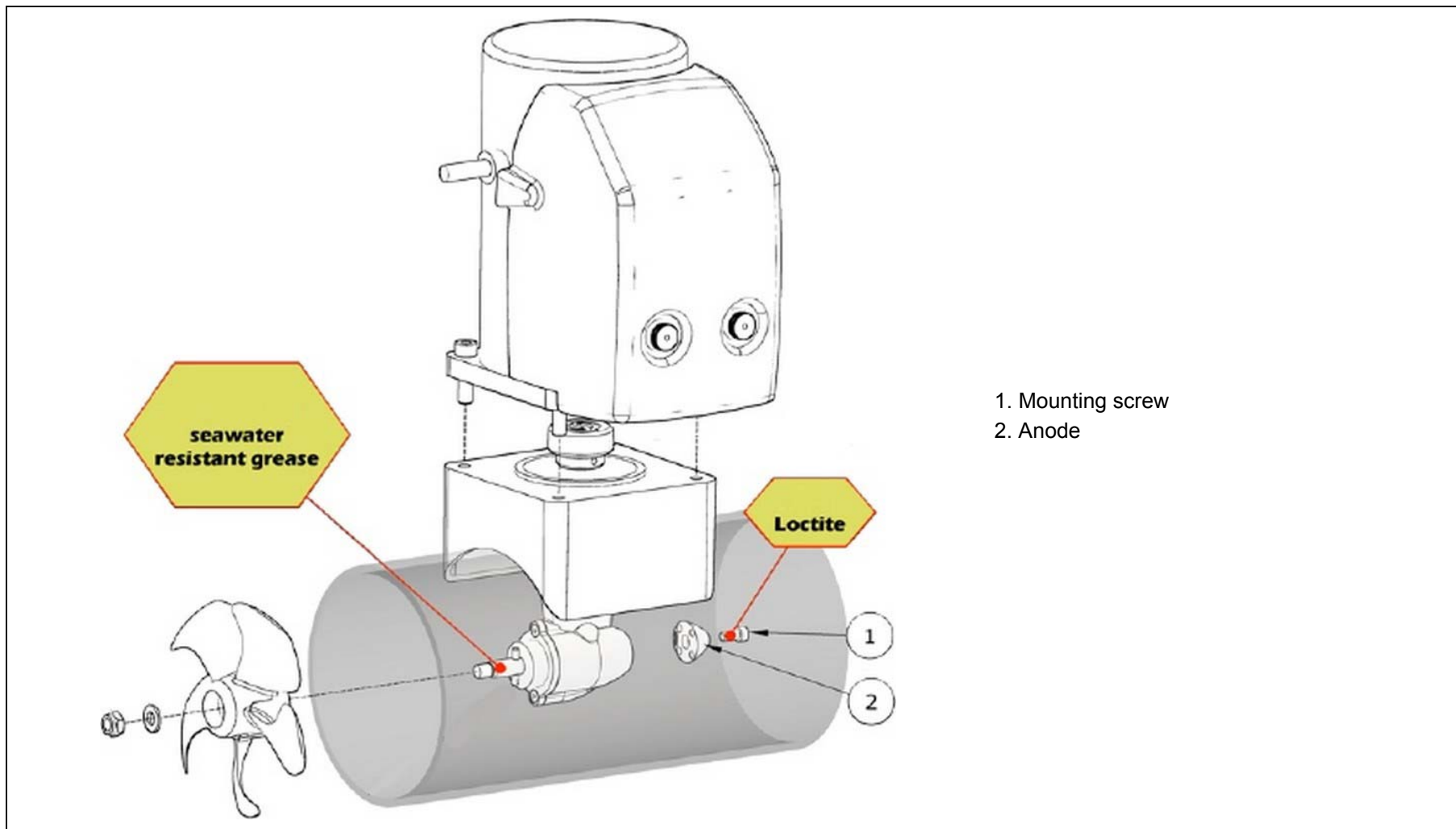

DECK FITTINGS

■ General points	224
■ Equipment.....	226
■ Berthing, anchoring, towing.....	229
■ Main elements of the chain locker.....	231
■ Electric windlass	232

16.1 GENERAL POINTS

Alcohol, solvent or acetone-based solutions must not be used to clean/maintain the outer surfaces of the boat. A warm, soapy, water-based solution is best for this purpose.

16.1.1 GRP

- Regularly brush the deck using a gentle de-greasing agent then rinse the deck with fresh water.
- Use as few cleaning agents as possible.
- Don't use solvents or aggressive detergents.
- Don't dump cleaning agents into the water: Consult the harbourmaster's office to find out the conditions of water use and the maintenance area for cleaning your vessel.
- Do not use a pressure washer.

16.1.2 Plexiglas (PMMA)

- Rinse plexiglas with fresh water.
- Use a polish paste for thin scratches.
- Consult your dealer if deep scratches occur.

16.1.3 Stainless steel

Stainless steel is an alloy of iron and carbon (steel) with the addition of chromium. The chromium creates a protective film which insulates the steel from the surrounding environment. This coating is usually invisible due to its thinness. Thus, despite its name, this steel is not stainless and requires a minimal level of maintenance:

- Chromed tools are preferable whenever handling stainless steel;
- Re-nourish the protective film regularly with passivating paste.



Never use solvents, alcohol, acetone or detergents on plexiglass.



Passivating paste is an acid-based product whose purchase and/or use may be subject to regulation. Please contact your dealer.

16.1.4 Solid wood on exterior wooden panelling

- Wood exposed to harsh conditions such as salty air and UV rays tends to become whiter and to lose its natural colour. This phenomenon has no effect on the intrinsic qualities of the wood, but can spoil its aesthetic appeal.
- To maintain the colour of the wood, regularly wash the woodwork in fresh water using a sponge (if necessary, use a mild soap).
- It is recommended that you oil the external woodwork regularly using teak oil in order to protect it from harsh conditions.

16.1.5 Exterior upholstery

- Bring the removable cushions inside (washed with soapy water then dried) when the vessel is unoccupied.
- Put canvas sheets/protective covering over the fixed upholstery.

Maintenance

To maintain the quality of the fabric, spray regularly with clarified water and brush with a soft brush (such as a clothes brush). A thorough clean every 2 years is recommended.

Stain removal

Follow these steps for routine cleaning:

- Remove as much debris as possible using a soft brush;
- Spray the fabric with water;
- Prepare a cleaning solution using mild soap and water (do not use detergent);
- Wash with a soft brush;
- Wait for the soap solution to act;
- Rinse thoroughly in fresh water;
- Dry in the open air.



Never use detergents, acetone or other harsh products on the wood.



If the wind exceeds 20 knots, it is recommended that you stow all removable protection sheets (Bimini, awnings...).



Never:

- use a heat source (hairdryer/clothes dryer);
- use detergent, silicone, acetone, chlorine-based products or hot water;
- use a high-pressure cleaner.

16.2 EQUIPMENT

16.2.1 Electric platform (Rear skirt)

General points

The platform runs on the DC power supply.

A circuit-breaker protects the circuit.

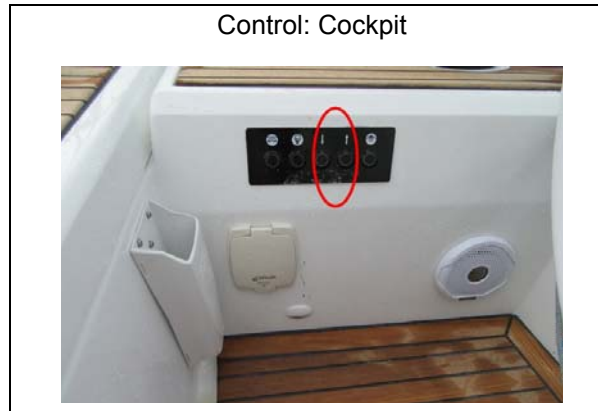
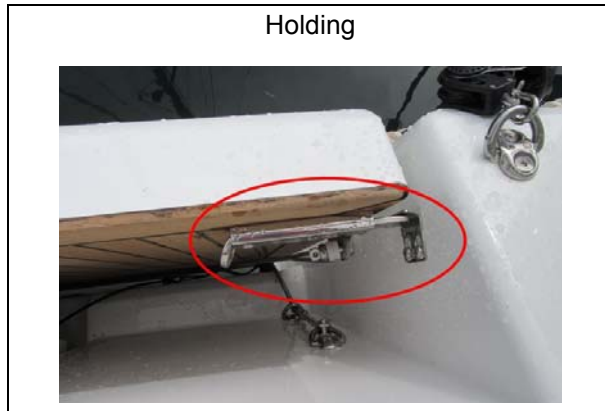
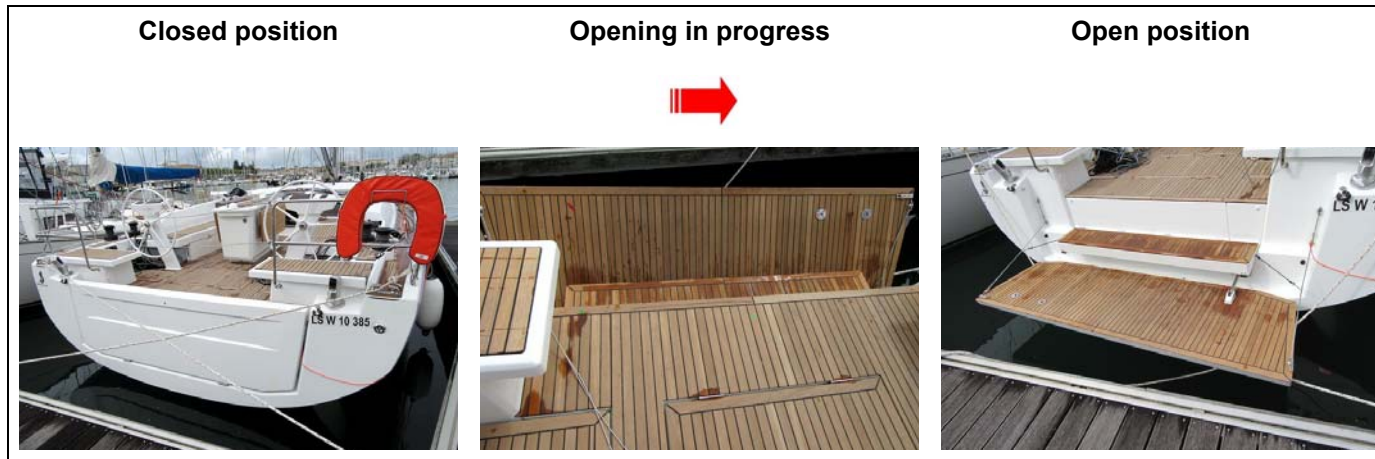

 Do not climb onto the platform while in motion.

-  - Do not use the rear platform while sailing.
- Maximum platform load = 300kg. (Load must be uniformly distributed).
 - During platform opening or closure:
 - Beware of the system's movements to avoid injuries.
 - Never leave children unattended when they are using the system.

 When you are using the platform remote control, check beforehand that the space in which it operates is completely clear of obstructions and remains so throughout the operation.

 Do not let a child operate the platform remote control on his/her own.

OPENING PLATFORM:

1. Switch the circuit breaker.
2. Remove the guard-rails from the swimming ladder.
3. Push the switch downwards.
4. Wait for the system to stop completely.

CLOSURE PLATFORM:

1. Push the switch upwards .
2. Wait for the system to stop completely.
3. Replace the swimming ladder guard-rails.
4. Switch off the circuit breaker of the relevant apparatus on the electrical panel.



- When not operating:
- Make sure the breaker is turned off.

Emergency Procedure



If the cylinder fails, you can close the platform manually by following the steps below:

- Shut off the DC supply of the cylinder by the circuit breaker;
- Remove the split ring (item 1) and the shaft (item 2) at the two cylinder fixings;
- Remove the platform cylinder and store it in the boat;
- Strike an end on the platform to raise it manually. It is possible to use a winch for this operation.

16.2.2 Davits

- The davits enable the launch and retrieval of the tender from the transom. Any other use is dangerous and must be strictly avoided.
- The davits are equipped with a pulley block for manoeuvring the tender. This pulley block is manoeuvred by hand.

Launching the tender

- Insert the bung.
- Secure the pulley's hooks to the front and back of the tender.
- Lower the front then the back of the tender alternately until it touches the water.

Retrieving the tender from the water

- Pull out the bung.
- Secure the pulley's hooks to the front and back of the tender.
- Raise the front and then the back of the tender alternately as high as the pulley block allows.



No one must be onboard the tender while launching or retrieving it.



- The davits are designed to support a maximum load of 180kg and a tender which is at most 3,10m long.



- Before heading out to sea, remove the outboard engine from the tender and store it on the boat.

- Secure the tender taking account of sea conditions.
- Secure the outboard engine to the tender once this is in the water.



16.3 BERTHING, ANCHORING, TOWING

16.3.1 Anchor points

Responsibility

It is the responsibility of the owner/user of the boat to ensure that the berthing lines, towing cables, chains and mooring lines and the anchors are adequate for the intended use of the boat, i.e. that the lines or chains do not exceed 80 % of the breaking strength of the corresponding anchor point.

	MOORING LINES	MOORING	TOWING
Reference (Diagram on next page)	A	A / B	A / B
Anchor Point Breaking Strength	37,1kN	53,2kN	53,2kN
Mooring Line/Chain Breaking Strength	29,7kN	42,6kN	42,6kN

Be sure to protect the transom platform with a fender to avoid friction with the pontoon.

Pass the warps through the fairleads provided.



 Anchoring points showing visible signs of deterioration must be replaced.

16.3.2 Towing

Responsibility: It is important that the owner thinks through the actions required when securing a towing cable onboard.

Location of attachment points

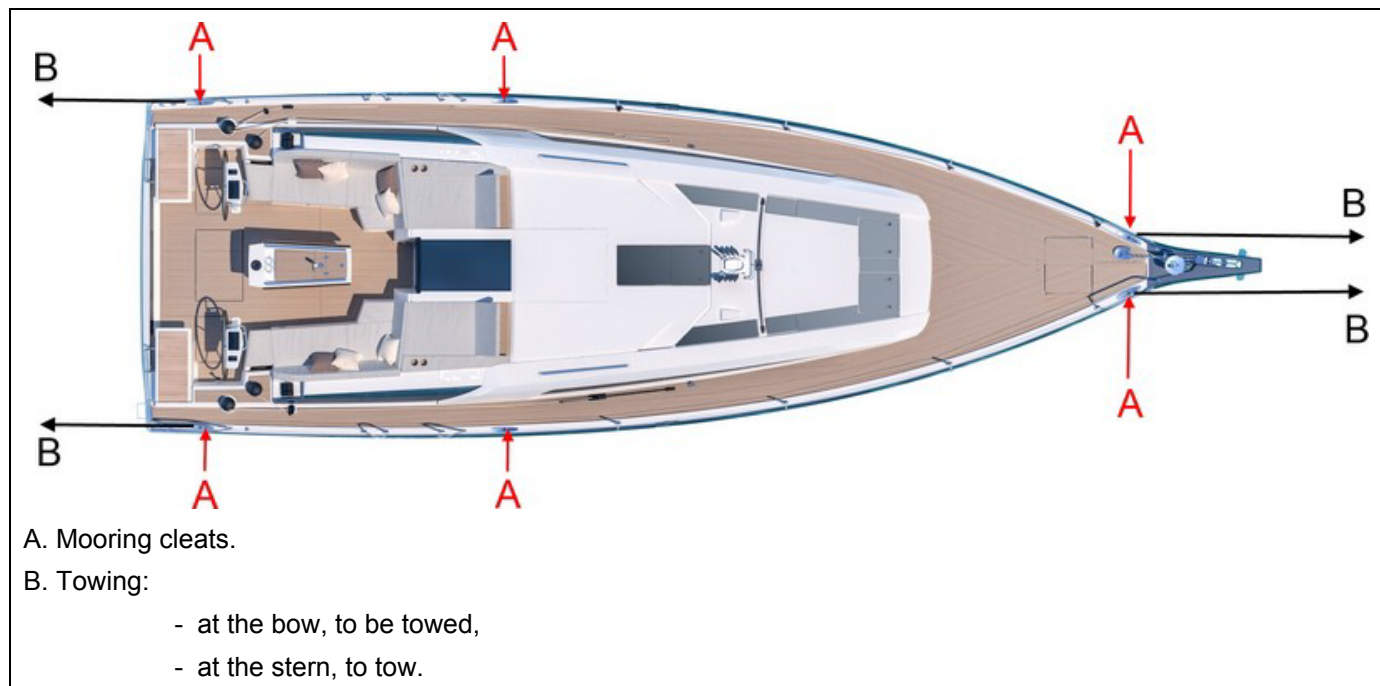

- Generally the breaking strength of lines/ chains must not exceed 80% of the breaking strength of the anchor points.
- Always tow or be towed at low speed. Never exceed the maximum speed of a displacement hull during a tow.
- Be particularly vigilant when the end of a towing cable is being thrown or received (the end may become caught in the propeller).
- A towing cable must always be secured in such a way that it can be released under load.
- Do not try to stop the boat by using a boathook or your foot, hand or any other part of your body.

16.4 MAIN ELEMENTS OF THE CHAIN LOCKER



- ! - Refer to the manufacturer's instructions for use and maintenance.
- Windlass operations are dangerous:
 - Always keep the anchor chain or rope free and unfouled;
 - Carry out manoeuvres carefully and always wear shoes;
 - Avoid wearing baggy clothing and jewellery that could get caught in the engine when it is running. Tie up long hair..

16.5 ELECTRIC WINDLASS

General points

- The windlass is DC powered.
- The windlass is designed for anchoring purposes: Any other use is dangerous and must be strictly avoided.
- An operation relay is fitted to the electrical circuit.
- A circuit-breaker protects the power supply to the windlass.
- The windlass operation is activated by an operational interlock relay which is powered by the engine's alternator: the windlass only works when the boat's engine is running.
- The controls to raise/lower the windlass are protected by a circuit-breaker positioned between the batteries and the windlass relay.
- Your boat may be equipped with a chain meter: this shows the length of chain let out.

Operation

- Before lowering the anchor, make sure that the chain or anchor rope is securely attached to the bitter end ring.

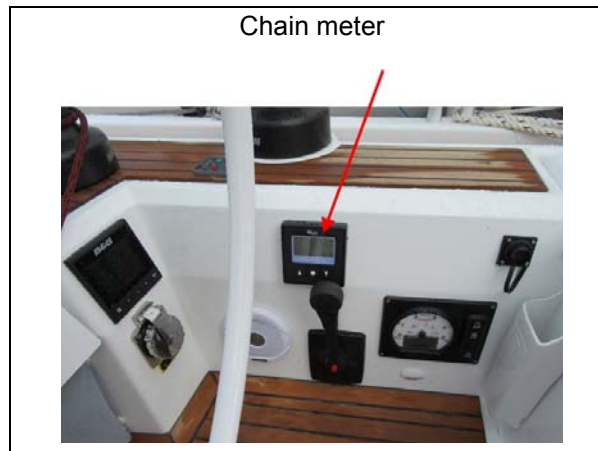
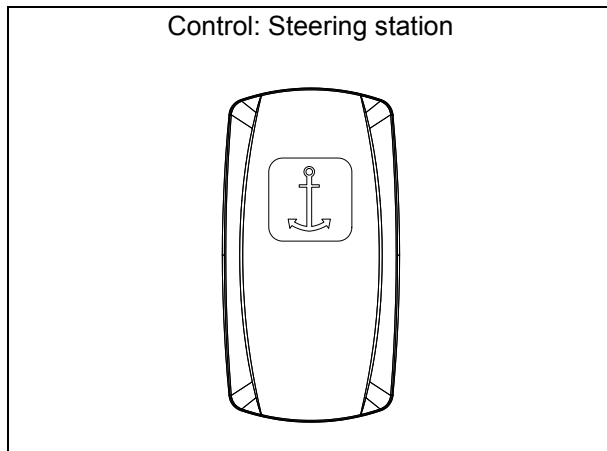

- **When at sea, secure the chain or anchor rope to secure points such as the chain stopper or the anchor rode to the belaying cleat (the windlass must not be used as the only method of securing the chain or rode).**
- With dual control, be careful to use only one control at a time.
- When raising the anchor, use the boat's engine to move towards the position of the anchor until the boat is just over it: never use the windlass as a winch to move the boat forward.
- When out at sea, cut the electrical supply to the windlass.
- Cut the electrical supply when using the windlass manually.

 Refer to the manufacturer's instructions for use and maintenance.

Maintenance

- Once a year, dismantle, carefully wash and grease all the moving parts of the windlass.
- Regularly grease the supply terminals of the electric motor of the windlass and of the relay control box.

Emergency anchoring procedure

In the event of an electrical fault, it is possible to lower the anchor manually: Put the handle in the space provided to release the chain sprocket. Let the chain run out using the handle to control the speed as it runs.



The handle serves only to release the chain sprocket in order to lower the anchor manually should the electric windlass break down.

The handle cannot be used to raise the anchor manually.



- Before anchoring check the depth of water, the power of the current and the nature of the sea bed.

- Check the swing radius once the boat is at anchor.

- After each trip rinse the windlass and anchor chain or rope with fresh water.

DIAGRAM OF LAYOUT - CHAIN METER

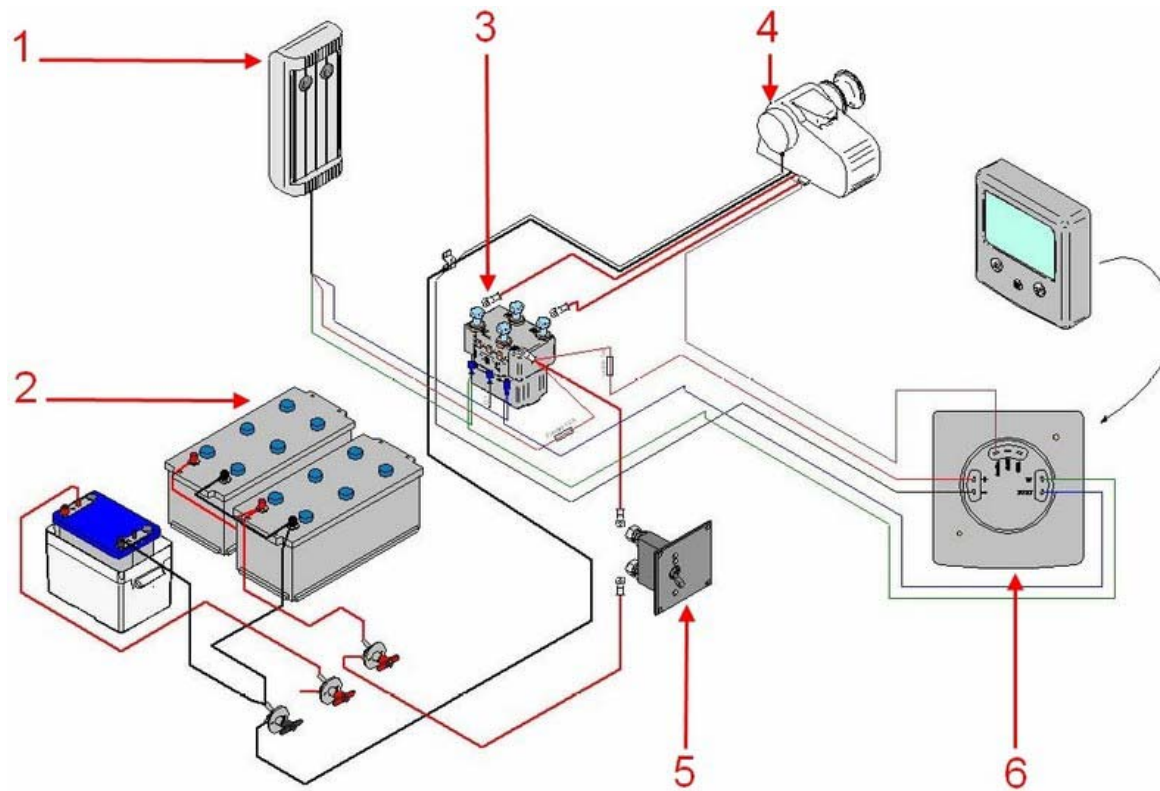

Reference	Designation
1	Remote control for the windlass
2	Service batteries
3	Operation relay
4	Windlass
5	Breaker
6	Chain meter

HULL FITTINGS

■ Interior upholstery	236
■ Interior woodwork	239
■ Interior maintenance	240

16.6 INTERIOR UPHOLSTERY

GENERAL POINTS

- The interior upholstery is designed for use inside the boat only.
- The fabric used inside the boat has not had any special treatment to protect it from a saline atmosphere or from UV.
- Make sure the curtains are drawn to protect the interior upholstery from exposure to sunlight.

LEATHER

Maintenance

Leather must be regularly cleaned and waxed.

To do so, clean the leather surface with a damp rag. This will remove dust.

Every 6 months to a year depending on use, apply a leather shampoo on the leather then use a hydrating cream which will also protect it.

Stain removal

If the leather surface gets stained, clean immediately using an absorbent piece of paper. Do not scour. Clean with inward motions to prevent the stain from spreading.

- Dab with denatured alcohol, using a piece of cotton to apply (ink and food stains).
- Apply absorbent powder (talcum) on grease stains.

Wait a couple of hours, then brush away the excess powder.

- Other: Apply white vinegar or acetic acid diluted in water.



- Test the product on a small hidden area of the surface before cleaning.
- Avoid excessive moisture.
- Do not scrub on leather surfaces.
- If you notice leather colouring on the rag, immediately stop cleaning.

ALCANTARA (microfibre)

Stain removal

The fabric must be free from dust before stain removal. To do so, use a vacuum cleaner.

Rub with a duster soaked in a solution containing ammonia diluted by 10%. Dilute to the strength appropriate for this fabric. Try it out first on a hidden area such as the hem. If the appearance of the fabric changes, dilute accordingly.

Scrub the Alcantara fabric in all directions, particularly on the stains.

Rinse off the cleaning solution using a damp cloth.

Dry in the open air.

After taking the Alcantara fabric off, it's a good idea to use a gentle brush to bring back its softness.

For difficult stains, dry-cleaning is recommended.

SYNTHETIC FABRIC

Stain removal

If you can remove the fabric:

- Clean in the washing machine (use the programme for delicate fabrics) at 30°.
- Do not iron.
- Never use Javel water.
- Do not dry-clean.
- Do not tumble-dry.

If you cannot remove the fabric:

- Clean with the vacuum cleaner,
- Clean with a foam for synthetic fabrics (see manufacturer's instructions for these products).

COATED FABRIC (PVC)

Maintenance

- The PVC must be regularly cleaned with soapy water to maintain its appearance and to avoid accumulation of debris. We strongly advise against using the following products: lacqueurs, aggressive cleaning products, detergents, xylene or acetone-based products which can cause permanent damage or make the fabric deteriorate. The use of such products is carried out at the owner's risk.

Stain removal

- All stains must be quickly removed to avoid formation of permanent stains.
- Use mild water to remove stains on the surface of the fabric. Use only clean, white, damp pieces of cloth.
- Difficult stains can be removed using a mixture of water (25%) and white spirit.
- Rinse with clean water.
- Dry with a soft piece of cloth.

ACRYLIC (bimini fabric)

Maintenance

To maintain the quality of the fabric, spray regularly with clarified water and brush with a soft brush (such as a clothes brush). A thorough clean every 2 years is recommended.

Stain removal

Follow these steps for routine cleaning:

- Remove as much debris as possible using a soft brush;
- Spray the fabric with water;
- Prepare a cleaning solution using mild soap and water (do not use detergent);
- Wash with a soft brush;
- Wait for the soap solution to act;
- Rinse thoroughly in fresh water;
- Dry in the open air.

16.7 INTERIOR WOODWORK

Varnished wooden panels:

The UV varnish has a matt appearance:

- The acrylic varnish has medium resistance to external chemical damage as well as minor scratches.
- Clean regularly with lukewarm soapy water.
- Do not use polish (this may result in unwanted brightening of appearance).
- For scratches, remove the panel and have it re-varnished by your dealer.

The acrylic varnish used has a matt appearance:

- The acrylic varnish features medium resistance to external chemical damage as well as minor scratches.
- The varnished surface tends to get dirty quickly since it is not flat and reveals hollow pores.
NOTE: Vigorously rubbing a varnish surface gives it a brighter appearance.
- Do not use polish (this may result in unwanted brightening of appearance).
- Gently and regularly clean with lukewarm soapy water.
- For scratches, remove the panel and have it re-varnished by your dealer.

Floors:

- The floors fitted onboard are laminated.
- Clean regularly with lukewarm soapy water.
- In the event of a scratch, remove the plank and replace it with a new one (consult your dealer).



- If in doubt or if stains persist, consult a cleaning specialist.
 - For winterisation, ensure the curtains are drawn to prevent prolonged exposure of the varnish and fabric to sunlight. This will prevent the risk of discolouration.
- NEVER:
 - use solvents or abrasive products;
 - use a heat source (hairdryer/clothes dryer);
 - use detergent, silicone, acetone, chlorine-based products or hot water;
 - use a high-pressure cleaner.

16.8 INTERIOR MAINTENANCE

- Take advantage of fine weather to air the interior upholstery.
- Remove the cushions during lengthy periods of absence.
- Make sure the bilges are clean and dry.
- For lengthy periods of absence, leave the icebox and fridge doors open to prevent mould from developing.
- Use a dehumidifier in the saloon and ensure cabin and storage doors are left open (cupboards, iceboxes...).

HANDLING, TRANSPORT

■ Lifting plan	242
■ Lifting.....	243
■ Keel	244
■ Upper limit of antifoul	245
■ Launching and lifting	245
■ Stepping and unstepping the mast.....	245
■ Winterisation.....	246
■ Transport.....	247

17.1 LIFTING PLAN

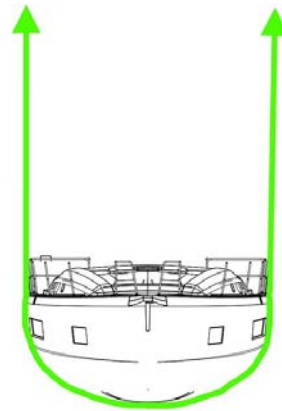
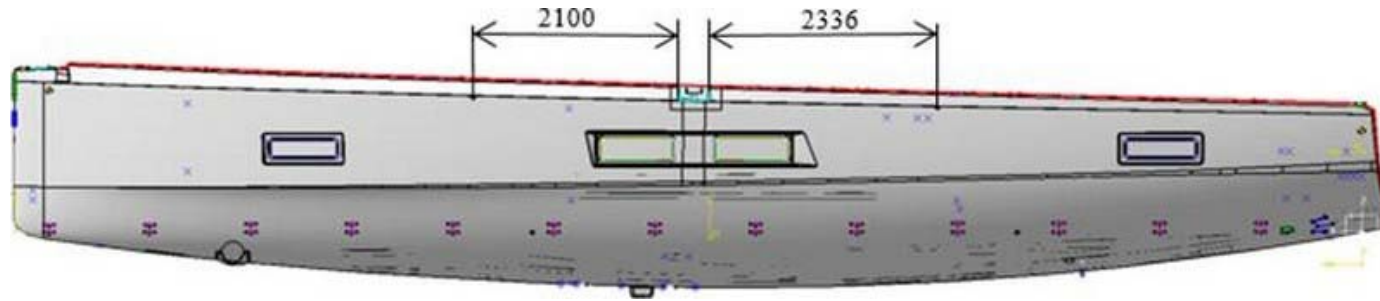

OK

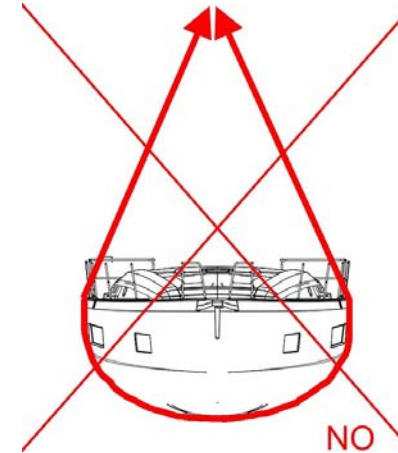

NO

Note: Measurements are expressed in mm.

The position of the lifting slings is shown in the pictogram below:

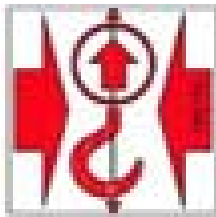

17.2 LIFTING

- Before the first application of antifouling to the hull, you can lightly sand the hull using wet and dry sandpaper of 400 µm or more.
- The lower hull of your boat should be covered with an anti-fouling paint to prevent the adhesion of marine growth.
- The water quality where your boat is kept, along with the frequency of lifting, will determine the choice of antifouling.
- All bronze or steel surfaces, including the propellers, should be protected by a suitable antifoul paint.
- During the lift-out, check the anodes and the propeller (see corresponding chapters).
- Antifouling can deteriorate when the boat is ashore or dried out: Please observe the out-of-water time limit set by the supplier.

Before applying antifouling NEVER:

- Do any sandblasting;
- Use any other solvents than ethylic alcohol;
- Use pressure washer detergents;
- Use scrapers;
- Use grinding tools.

If cleaning off existing antifouling requires high pressure washing:

- Ensure the water temperature does not exceed 15 degrees;
- The water pressure must not exceed 150 bar (2175 PSI);
- The distance between the hose nozzle and the hull must not be less than 10 centimetres.

The wet surface area of the boat is approximately: 52m².



- Follow the manufacturer's recommendations closely when applying antifouling.
- Never let antifouling cover:
 - the anodes;
 - the earthing plates (Generator / DC/AC converter);
 - the refrigeration unit condenser;
 - the sensors of the electronic instruments.
- the sail-drive baseplate must be covered with copper-free antifouling.
- Avoid using copper or tin-based antifouling: these are banned in some countries.

17.3 KEEL

General points

The keel is the appendage located under a sailing yacht. It is fundamental component for stability and is essential to the boat's operation.

The keel is fixed to the bottom of the hull by bolts or pins and nuts with the corresponding tightening torque.

Maintenance

The keel constitutes a part of the hull below the waterline. It must be protected with anti-fouling paint.

Each time the hull is cleaned and at least once a year, inspect the condition of the keel and the join between the keel and the hull visually. Any fault, crack or splintering must be reported to your dealer or a professional who will give you the correct advice.

Yearly inspection

Make a visual inspection of all the ballast fixings under the floors. Make sure there are no cracks around the washers, bolts or nuts and that there is no significant corrosion. Any work carried out on these components must be done professionally.

In the event of an incident

In the event of grounding or impact with an unidentified floating object, lift the floors and check that there is no leakage of seawater in the ballast area. Do the same in the area of the rudder mountings.

If there is a leak of seawater (even a small one), reduce speed, contact the emergency services and follow their advice.

Take the boat out of the water immediately and have it professionally inspected.

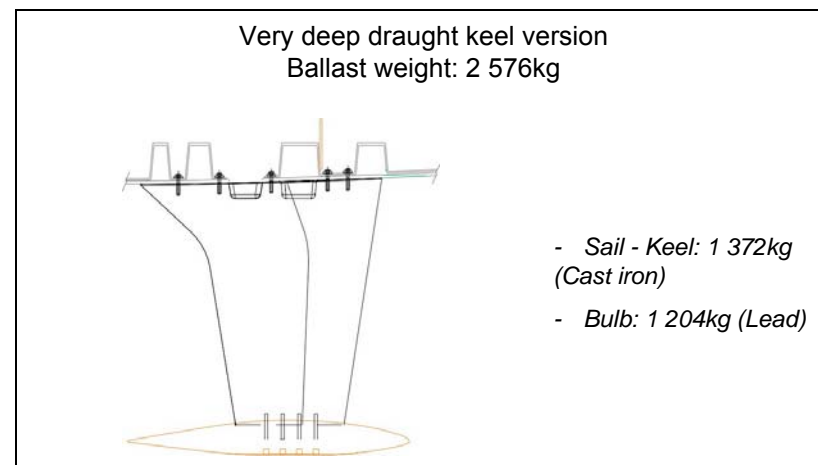
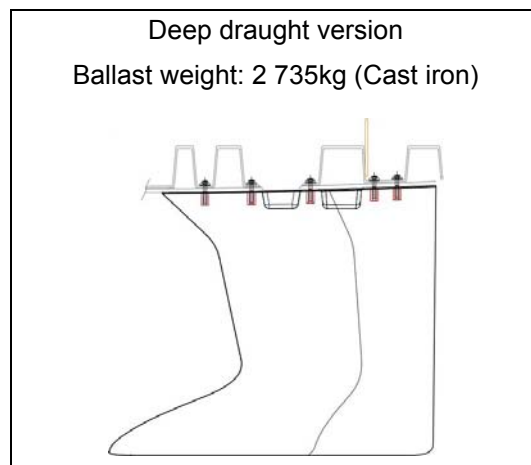
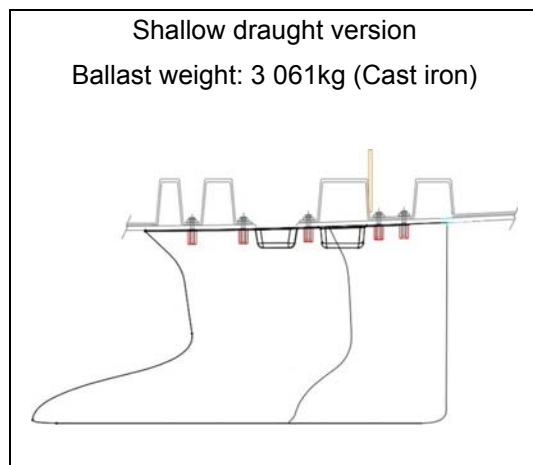

17.4 UPPER LIMIT OF ANTIFOUL

The boat's hull has a shallow indent moulded along its length: the upper marking corresponds to the upper limit of antifoul on the hull.

17.5 LAUNCHING AND LIFTING

The first time you use your boat a high level of skill and attention will be required. The proper functioning of all equipment will depend on the initial set-up being carried out correctly. For this reason the first launch must be carried out under your dealer's supervision.

Before launching

- Replace the speedometer in its housing.
- Check the cleanliness of the seawater filters.
- Check the anodes (see Chapter: ELECTRICAL SYSTEM).
- Check the propeller/hydrolube bush (see Chapter: STEERING SYSTEM).
- Prepare enough fenders and lines.
- Check the engine's seawater intake valve and the fuel feed valve (see Chapter: ENGINE).

17.6 STEPPING AND UNSTEPPING THE MAST

The stepping/unstepping operations require the skills of a professional rigger: please consult your dealer.



Do not stand onboard or beneath the boat during the handling operations.



- When placing the slings make sure that the positioning marks are still visible.
- Immerse the sling fully under the engine mounting.

17.7 WINTERISATION

- Take advantage of laying-up to carry out a full inventory of the equipment.
- Check the expiry dates of the safety equipment.
- Have the liferaft overhauled.
- Empty the complete water system inside and outside and rinse it through with a mix of water and vinegar (do not use chlorine-based products).
- Empty and rinse the entire blackwater system.
- Dry out and clean the boat's bilges.
- Grease and close all the valves and thru-hull fittings.
- Close all the boat's seacocks.
- Remove the depth sounder and speedometer heads.
- Put the covers back on the electronic screens.
- Use a dehumidifier in the saloon and ensure cabin and storage doors are left open.
- Air all of the cushions and upholstery for a while before putting them back onboard and arranging them so as to limit contact between surfaces.
- Close the blackout curtains.
- Leave the fridge/icebox doors open to prevent mould and smells from developing.
- Protect the boat as well as possible with fenders.
- Make sure the boat is properly moored.
- Grease all mechanical and moving parts (bolts, hinges, locks...).
- Remove the sails and store them somewhere dry and well-ventilated.
- Remove the movable upholstery.
- Disconnect the batteries. Make sure you recharge them during the Winter period if the boat is left inactive for a long time.



- Engine winterisation requires a professional engineer: please consult your dealer.
- This is not an exhaustive list of recommendations: Your dealer will give you the advice you need and will carry out technical maintenance of your boat.

17.8 TRANSPORT

PACKING PLAN Boat without keel on cradle

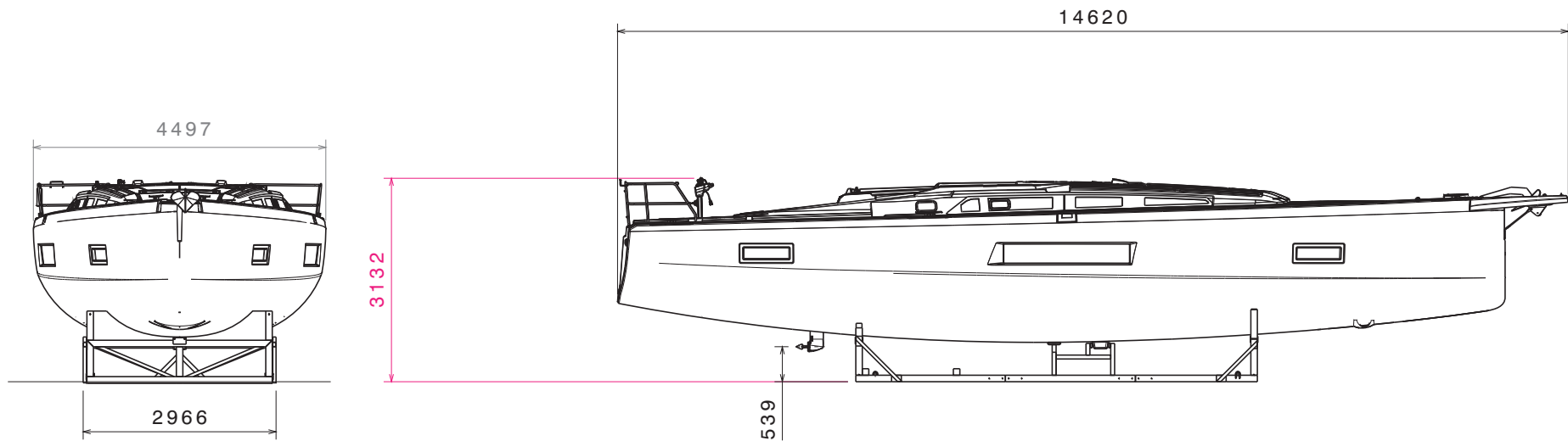

Boat with keel on cradle

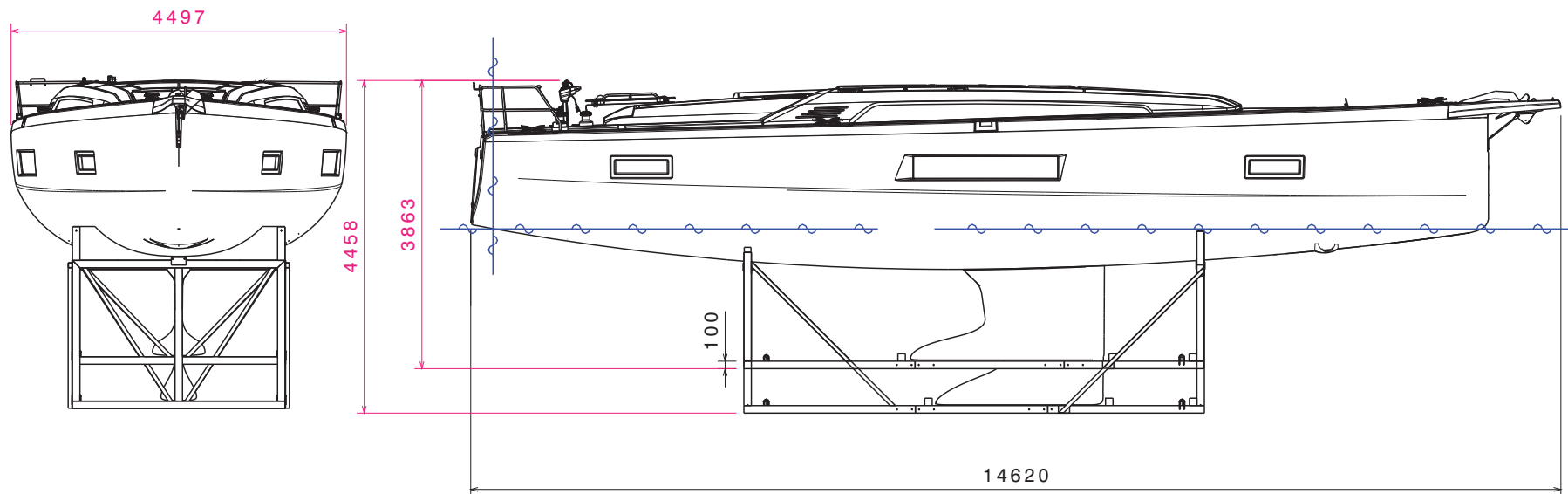

Note: Measurements are expressed in mm.

ENVIRONMENT

■ Waste management.....	250
-------------------------	-----

18.1 WASTE MANAGEMENT

- Throw all packaging in the recycling containers provided.
- Once a piece of equipment has stopped working completely, find out about the relevant recycling regulations from your nearest recycling centre or from your dealer.
- Make sure you follow the relevant local laws when scrapping.
- Some onboard equipment can have a toxic effect on the environment and on human health due to the specific substances they contain: Do not throw any equipment in household waste containers and absolutely never dispose of equipment in the sea.
- Dead batteries are toxic to health and to the environment. Batteries must not be put in with household waste and must be recycled separately. Contact the harbour master or a specialist company about recycling them.









- Make sure you know the local environmental regulations and follow the codes of best practice.
 - Do not pump out the toilets or the contents of the black water tank near the coast or in areas where this is forbidden. Use the pump-out facilities available in ports or marinas to empty the contents of the black water tank before leaving port.
 - Make sure you know the international regulations to prevent pollution in the marine environment (MARPOL Convention) and follow these as much as possible.

APPENDIX

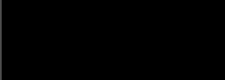
■ Label key	252
-------------------	-----

LABEL KEY

					
Engine group	Plumbing group	Colour - WC group	General electrical equipment	Comfort group	Drainage group



Valve location label

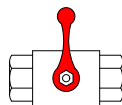



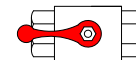





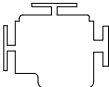







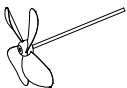

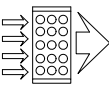





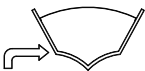





Closed valve

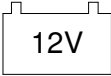

Open valve

Meaning of the symbols

	Motor		Shower		Electric pump
	Port engine		Washbasin		Manual pump
	Starboard engine		Ice maker		WC Toilet
	Propeller shaft		Deck wash		Washer
	Filter		Sea water tap		Dryer
	Hull drainage		Waste water tank		Dishwasher
	Sea water intake		Fresh water tank		Watermaker

	Shore power socket		Fuel tank		Fuel filter
	Service		Holding tank		Inverter
	Generator		Battery stock		Heating
	Breaker		Thruster		Air conditioning

Each label is defined by:

- a functional group (specific colour);
- a component.

